

C 95

Digital Panel Meters

Programmable $\pm 10,000$ points



The C 95 is one of a series of highly accurate digital panel meters.

Each instrument has a highly legible 10,000-point 5-digit red display, whose brightness is ideally suited to use in industrial control rooms.

The C 95 is the perfect choice for displaying. Monitoring and transmission of process data from any source in the plant.

A simple 4-key touch-button control facilitates programming and subsequent operation.

Input	Features
<p>DC current or voltage Bidirectional ± 100 mV, ± 1 V, ± 10 V, ± 300 V, 20mA</p>	<ul style="list-style-type: none"> • Accuracy 0.05% of full scale at +25 °C • Thermal drift < 150 ppm/°C • Scale overlapping measurable from -5% to +5% • Programmable scale factor • Enlarging effect - Square root extraction • Special linearisation 20 points • Supply for 2 or 3 wire sensor 26 VDC ($\pm 15\%$) up to 25 mA protected from short-circuits
Output	Features
<p>Analog output: 3 types available A1: Active current output 0/4...20 mA</p>	<ul style="list-style-type: none"> • Accuracy 0.1 % in relation to display (at +25°C) • Residual drift $\leq 0.2\%$ • Admissible load: $0 \Omega < R_c < 500 \Omega$ (current) $R_c > 2 \text{ k}\Omega$ (voltage) • Programmable scale ratio with enlarging effect • Response time: 40 ms
<p>Relay output: 2 types available R: 2 set point relays, independently programmable R4: 4 set point relays, independently programmable</p>	<ul style="list-style-type: none"> • Hysteresis independently programmable from 0 to 100% of set point in the display unit • Temporisation independently programmable from 0 to 25 s in 0.1 s steps • NO-NC contact 8 A - 250 V on resistive load
<p>Digital output N: Data link RS485 (2 wires)</p>	<ul style="list-style-type: none"> • Protocols MODBUS-JBUS data format: Integer / double integer • Slave number programmable from 1 to 255 with a rate from 1200 to 19200 Bauds

Technical Data

Display	Approx. 10,000 points (14 mm) Electroluminescent red (green as option) 4 alarm messages -10 000 / +100 000 points (14 mm) (as option); -2 000 / +10 000 points (20 mm)
Features	
Sampling times	100 ms
Input impedance	≥ 1 MΩ for voltage inputs
Drop	0.9 V max. for current input
Rejection rate	Common mode: 130 dB Mode series: 70 dB 50/60 Hz
Insulation	Input / Output: 2.5 kV eff. 50Hz-1min Inputs / Power Supply: 2.5 kV eff., 50 Hz- 1min
Zero drift compensation and self-calibration	
Programmable integration index	Allows stabilising display in case of unsteady input
Sensor or line rupture detection	Can be detected on inputs mV, TC, Pt 100, Ni 100, ΔPt 100, resistance (0-400Ω) and current (4-20 mA) Return value programmable for the analogue output in case of sensor rupture Sensor rupture detection programmable for the 4 relays Possibility to disconnect sensor rupture
Self diagnosis	Permanently monitors any component drift that may surge Serves to warn the user before they provoke false readings Self diagnosis error detection programmable for the 4 relays Return value programmable for the analogue output in case of error self-diagnosis.
Input scale overlapping	Visualised on the display by flashing reading
Linearisations	Linear input Square root extraction (current or voltage inputs) Special linearisation on 20 points (in X and in Y) (voltage or current input)
Shifted scale (inclination and offset)	Programmable on all inputs.
Brightness	Independent setting of brightness of digits and bar graph LED's Programmable: 4 levels according to instrument location (outside, control room, etc.)
Fast reading on the display	Set point values Input signal electrical value Min. and max. values
Simulation function	Possible simulation of analog output (mode simulation) Possible simulation of measure: enables validating the analog output and relay outputs configuration in the system
Process input	One bi-directional DC current or voltage input ±100mV, ±1V, ±10V, ±300V, ±20mA
Output options	
Analogue insulated output	Active or passive current output or voltage output Programmable scale ratio, with enlarging effect Return value in case of sensor rupture and/or error self-diagnosis
Relay output	2 or 4 relays: mode set-point or window Recording of alarms Temporisation and hysteresis adjustable on each set-point Alarm messages
Insulated digital output	RS 485 2 wires, protocol MODBUS-JBUS
Connectors	Plug-off connectors on rear side for screwed connections (2.5 mm ² , flexible or single-strand)
Power supply	
High voltage	90...270 VAC 50/60/400 Hz; 88 ...350 VDC
Low voltage	20...53 VAC 50/60/400 Hz; 20...75 VDC
Power consumption	5 W max. 8 VA max
Protection	
Front face	IP 65
Case/terminals	IP 20

Approvals

Emission and immunity in industrial environment

EN 50081-2; EN 50082-2
 EN 61000-4-2 level 3, EN 61000-4-3 level 3, EN 61000-4-4 level 4,
 EN 61000-4-6 level 3

CE

According to directive CEM 89-336

Environment

Front face protection IP 65
 Operating temperature -5...55°C
 Storage temperature -30°C...+80°C
 Relative dampness 80% annual average
 Weight with / without output board 250g / 150g
 Connection with screwed plug-off connectors (for 2.5 mm² cable, flexible or single strand)
 Case in self-extinguishing black UL 94 VO ABS

Dimensions

Case : 96 x 48 x 124 mm (including terminals)

Mounting : on panel;
 cut out 44 x 91 mm

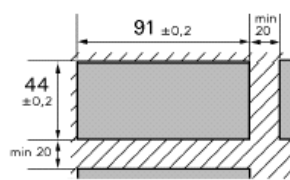
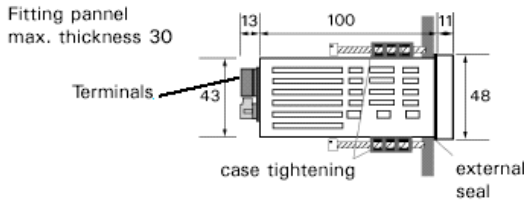

Electrical connections

Locations of options and combinations

Any options can be combined, except one case
 Options: LOGIC, 4 relays, and the analogue output

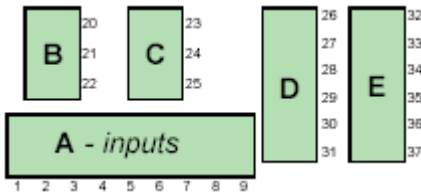

- A: inputs
- B: option N (digital output)
- C: option A (analogue output)
- D: option R (2 relays only)
- E: option R4 (2+2 relays)

Power supply

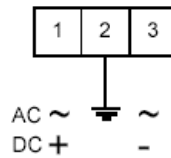

Inputs

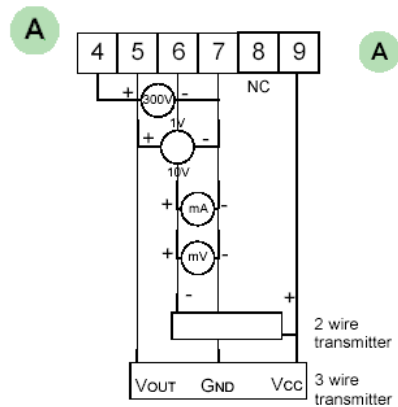

Outputs Digital

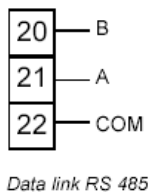

Data link RS 485

Active current

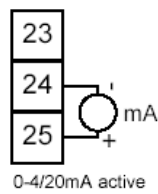

2 Relays

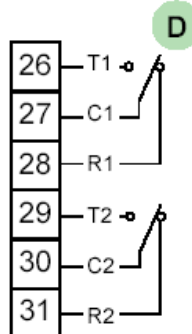

4 Relays

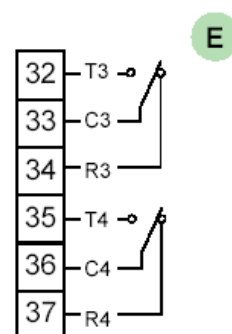

T: No C: Common R: NC

Access code

An access code settable from 0000 to 9999 prevents unauthorised programming of indicator, set points and locks access to some functions. The factory code is 0000.

- 0 - 5 Access to fast entering of alarm set-points
- 6 - 9 No access

- 0 - 5 Access to function "tare" (except t° inputs)
- 6 - 9 No access

- 0 - 5 Access to measurement and output simulations
- 6 - 9 No access

- 0 - 5 Access to shifted scales
- 6 - 9 No access

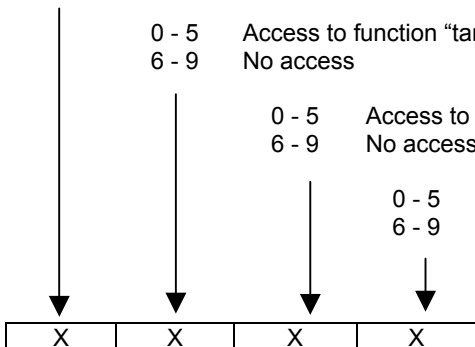

Ordering code

Output options:

- A** Analogue
- R** 2 relays
- R4** 4 relays
- N** Digital link (RS 485 2 wires)

Power supply:

- 2 High voltage
- 3 Low voltage

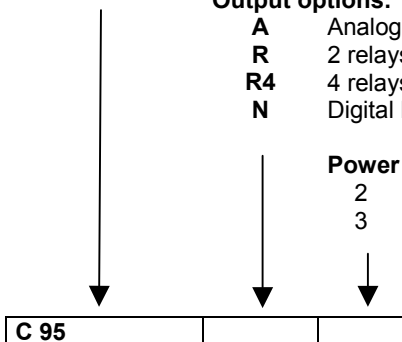

**This instrument is designed for industrial applications.
It has to be mounted in an electrical switchbox, or similar.**

United Kingdom

KROHNE Ltd.
Rutherford Drive
Park Farm Industrial Estate
Wellingborough
Northants NN8 6AE, UK
TEL.: +44(0)19 33-408 500
FAX: +44(0)19 33-408 501
e-mail: info@krohne.co.uk

USA

KROHNE Inc.
7 Dearborn Road
Peabody, MA 01960
TEL.: +1-978 535-6060
FAX: +1-978 535-1720
e-mail: krohne@krohne.com

Other countries

KROHNE Messtechnik GmbH & Co.KG
Ludwig-Krohne-Str. 5
D-47058 Duisburg
TEL: +49(0)203-301-0
FAX: +49(0)203-301-389
e-mail: krohne@krohne.de