

Electromagnetic flowmeters

- Primary heads
- Compact flowmeters

VARIFLUX IFS 6000 F

**IFM 6010 K
IFM 6020 K
IFM 6080 K**



IFS 6000 F

CONTENTS

Installation in the pipeline

Pages 4-5 and 7-8

Grounding

Pages 8-9



IFM 6010 K



IFM 6080 K

Contents

System description	2
Product liability and warranty	2
Standards and approvals	2
Items included with supply	3
1 Important information for installation: PLEASE NOTE	4-5
2 Suggestions for installation	5
3 Instrument nameplate	6
4 Flowmeter versions	6
5 Installation in the pipeline and torques	7
6 Limits	8
7 Grounding	8-9
8 Service	10
9 Spares and order numbers	10
10 Technical data	11
11 Dimensions and weights	12-14
Printed form to accompany flowmeters returned to Krohne	15

System description

VARIFLUX electromagnetic flowmeters are precision measuring instruments designed for the linear flow measurement of process liquids.

The process liquids must be electrically conductive: $\geq 5 \mu\text{S/cm}$
 $\geq 20 \mu\text{S/cm}$ for demineralized cold water

The **full-scale range** $Q_{100\%}$ can be set as a function of the **meter size**:

DN 2.5 - 80 / $1/10''$ - 3" $Q_{100\%} = 0.01 - 220 \text{ m}^3/\text{hr} = 0.03 - 960 \text{ US Gal/min}$

This is equivalent to a flow velocity of 0.3 - 12 m/s, or 1 - 40 ft/s.

Product liability and warranty

VARIFLUX electromagnetic flowmeters are designed solely for measuring the volumetric flowrate of electrically conductive, liquid process products.

Special codes and regulations apply to their use in hazardous locations, and these are referred to in the special "Ex" installation and operating instructions (supplied only with hazardous-duty equipment).

Responsibility as to suitability and intended use of these electromagnetic flowmeters rests solely with the operator.

Improper installation and operation of the flowmeters (systems) may lead to loss of warranty.

In addition, the "General conditions of sale" forming the basis of the purchase contract are applicable.

If VARIFLUX flowmeters need to be returned to Krohne, please note the information given on the last-but-one page of this manual. Krohne regrets that they cannot repair or check your flowmeter(s) unless accompanied by the completed form sheet.

Standards and approvals

Please refer to the installation and operating instructions for the signal converter.

Items included with supply

IFS 6000 F primary head

- primary head in the size as ordered
- certificate of calibration data
- installation instructions

IFM 6010 K, IFM 6020 K and IFM 6080 K compact flowmeters

- compact flowmeter in the size as ordered
- certificate of calibration data
- installation instructions
- installation and operating instructions for the signal converter

• Available meter sizes/types and connections

* not to ISO 2037

		Aseptic weld-on connections for pipes to DIN 11 850		Aseptic weld-on connections for pipes to ISO 2037		Connection and pipe flanges to DIN 2501 / PN 40		Connection and pipe flanges to ANSI B 16.5 / 150, 300 lb		Connection and pipe flanges to JIS 2210 / 20 K		Dairy screw connections and hose nozzles (option) to DIN 11851		Screwed pipe connections to ISO 2853		Screwed pipe connections to SMS 1145		Clamp joints to ISO 2852	
mm	inch	mm	mm	inch	mm	inch	mm	mm	mm	mm	mm	inch	mm	mm	mm	mm	mm	inch	
DN 2.5	1/10	DN 10	12	–	DN 10	1/2	DN 10	DN 10	12	–	–	12	–						
DN 4	1/8	DN 10	12	–	DN 10	1/2	DN 10	DN 10	12	–	–	12	–						
DN 6	1/4	DN 10	12	–	DN 10	1/2	DN 10	DN 10	12	–	–	12	–						
DN 10	3/8	DN 10	12	–	DN 10	1/2	DN 10	DN 10	12	–	–	12	–						
DN 15	1/2	DN 15	18	–	DN 15	1/2	DN 15	DN 15	18	–	–	18	–						
DN 25	1	DN 25	25	1 *	–	–	–	DN 25	25	–	–	25	25	–					
DN 40	1 1/2	DN 40	38	1 1/2	–	–	–	DN 40	38	1 1/2	–	38	38	1 1/2					
DN 50	2	DN 50	51	2	–	–	–	DN 50	51	2	–	51	51	2					
DN 65	2 1/2	DN 65	63.5	2 1/2	–	–	–	DN 65	63.5	2 1/2	–	63.5	63.5	2 1/2					
DN 80	3	DN 80	76.1	3	–	–	–	DN 80	76.1	3	–	76	76.1	3					

Items included with supply (Arrangement of gaskets and grounding rings see Sect. 7).

Flanged units:

with mounted grounding rings E and fitted gaskets D1.

Gaskets D2 not included, to be provided by customer.

Other connections:

mounted adapter with fitted O-ring gaskets D1 and union nuts

(counterparts for the pipeline, such as tapered connectors, union nuts,

hinged clamps and gaskets D2 not included, to be provided by customer).

Inside diameter of measuring tube and pipeline

Size Type		Inside diameter Ø di of measuring tube in mm (inch) for connections to ...		Pipe standard to DIN 11850		Pipe standard to ISO, SMS, RJT, JIS OD-Tube	
mm	inch	DIN	ISO, SMS, ect.	Meter size	Ø di mm	Meter size	Ø di mm
DN 2.5	1/10	2.5	2.5	/	/	/	/
DN 4	1/8	4	4				
DN 6	1/4	6	6				
DN 10	3/8	10	10				
DN 15	1/2	13	13				
DN 25	1	26	23	DN 25	26	DN 25/1"	23
DN 40	1 1/2	38	36	DN 40	38	DN 40/1 1/2"	36
DN 50	2	50	49	DN 50	50	DN 50/2"	49
DN 65	2 1/2	66	60	DN 65	66	DN 65/2 1/2"	60
DN 80	3	81	73	DN 80	81	DN 80/3"	73

1 Important information for installation: PLEASE NOTE

- Handling**

Do not lift flowmeter by the signal converter housing or the terminal box.

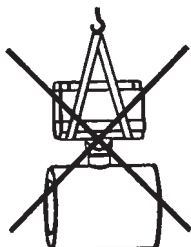

Do not set flowmeter down on signal converter housing or terminal box.

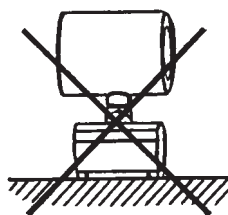

- Use only solventless detergents to **clean** the signal converter housing (polycarbonate).

- Temperatures**

For operating pressure and vacuum load based on connection standards, see Section 6 "Limits".

	Ambient temperature	Product temperature
Compact systems	-25 to +60 °C (-13 to +140 °F)	-20 to + 60 °C (-4 to +140 °F)
	-25 to +40 °C (-13 to +104 °F)	-20 to +140 °C (-4 to +284 °F)
- EEx version	-25 to +40 °C (-13 to +104 °F)	-20 to +140 °C (-4 to +284 °F)
IFS 6000 F	-25 to +60 °C (-13 to +140 °F)	-20 to + 60 °C (-4 to +140 °F)
- flange connections	-25 to +40 °C (-13 to +104 °F)	-20 to +180 °C (-4 to +356 °F)
- other connections	-25 to +40 °C (-13 to +104 °F)	-20 to +140 °C (-4 to +284 °F)
- EEx version	-25 to +40 °C (-13 to +104 °F)	-20 to +140 °C (-4 to +284 °F)

- Location and position as required**, but electrode axis **X - · - · - · - X** must be approximately horizontal in a horizontal pipe run.

Y terminal box or converter housing

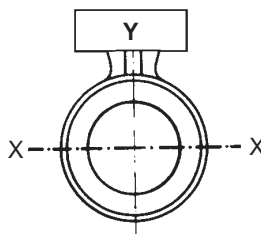

- Measuring tube must be completely filled at all times.**
- Direction of flow is arbitrary.** Arrow on flowmeter can normally be ignored. For exceptions, refer to Section "Factory settings" in the installation and operating instructions for the signal converter.
- Stud bolts and nuts:** to fit, make sure there is sufficient room next to the pipe flanges.
- Vibration:** support the pipeline on both sides of the compact flowmeter. Level of vibration in conformity with IEC 068-2-34: 20-500 Hz, random / 2g runs / 30 minutes / x, y, z directions.
- Do not expose to direct sunlight,** fit a sunshade if necessary, not included with flowmeter, to be provided by customer.

- **Strong electromagnetic fields**, avoid in vicinity of flowmeter.
- **Straight inlet run minimum of $5 \times \text{DN}$ and outlet run minimum of $2 \times \text{DN}$** , (DN = meter size), measured from the electrode axis.
- **Vortex and corkscrew flow**: increase length of inlet and outlet runs or install flow conditioners.
- **Mixing different process liquids**: install flowmeter upstream of mixing point or at an adequate distance downstream (minimum of $30 \times \text{DN}$), otherwise display may be unsteady.
- **Plastic pipes and internally coated metal pipelines**: grounding rings required, see Section 7 "Grounding".
- **Insulated pipeline**: do not insulate flowmeter.
- **Zero setting not necessary**. To check, it should be possible to set "zero" flow velocity in the completely filled measuring tube. Shutoff valves should therefore be provided either downstream of the flowmeter or upstream and downstream of the flowmeter.

2 Suggestions for installation

To avoid measuring errors due to gas/air inclusion or to pipe running empty please observe the following:

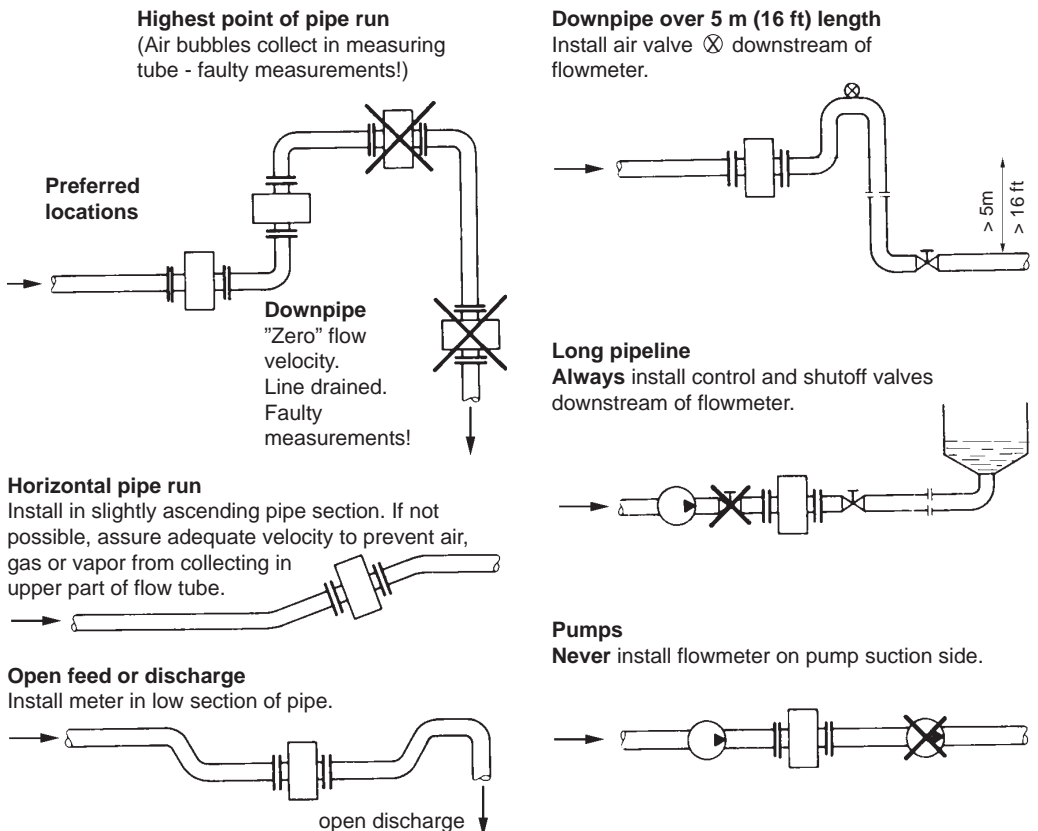

3 Instrument nameplate

IFS 6000 F

separate primary head

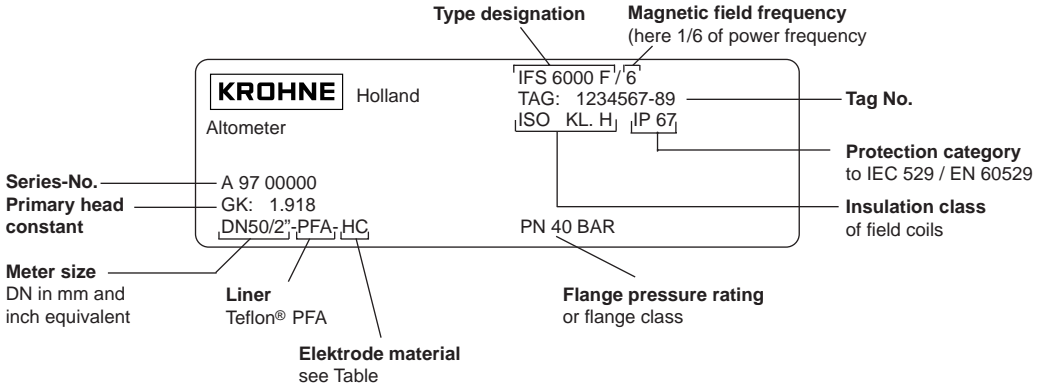

Teflon® is a registered trademark of Du Pont

Instrument nameplate for compact flowmeters
see installation and operating instructions for the signal converter.

Electrode Materials

HC	Hastelloy C4
PT	Platinum
TA	Tantalum
TI	Titanium
V4A	Stainless steel 1.4571

4 Flowmeter versions

IFS 6000 F **Separate primary head (F)**, electrically connected to the signal converter by signal and field current cables.

IFM 6010 K **Compact flowmeter (K)**, IFC 010 K or IFC 020 K signal converter mounted direct on the primary head.

IFM 6080 K **Compact flowmeter (K)**, IFC 090 K signal converter mounted direct on the primary head.

Versions for hazardous locations

IFS 6000 F and IFM 6080 K are approved as electrical equipment to the harmonized European Standards and to Factory Mutual (FM).

Test certificate, certificate of conformity and wiring instructions for these devices are attached to the **“Ex” installation instructions**, provided only with hazardous-duty equipment.

5 Installation in the pipeline

- **Installation material**, see page 3.
- **Pipe and operating pressures**, see Section 6 "Limits".
- **Flange spacing**
= dimension "a" + 2 x gasket thickness of D2
(dimension "a": see Sect. 11 "Dimensions and weights";
arrangement of gaskets: see Sect. 7 "Grounding").
- **High-temperature pipelines**
Where process temperatures exceed 100 °C/212 °F, provide for facilities to compensate for longitudinal expansion on heat-up of the pipeline.
For **short** pipelines use resilient gaskets and
for **long** pipelines install flexible pipe elements (e.g. elbows).
- **Position of flanges**

Install flowmeter in line with the pipe axis. Pipe flange faces must be parallel to each other, max. permissible deviation:

$$L_{\max} - L_{\min} \leq 0.5 \text{ mm} \\ \leq 0.02''$$

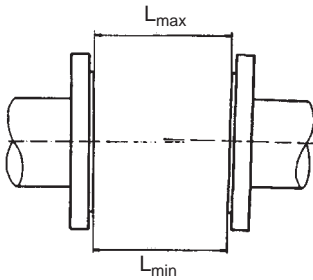

- **Torques**

For all flanged instruments to DIN, ANSI and JIS

Tighten down stud bolts and nuts uniformly in the sequence (1-8) shown in the drawing.

Max. torque:

32 Nm ~ 3.2 kpm ~ 23.1 ft x lbf

For all other connections to DIN and ISO

Tighten down to metal stop.

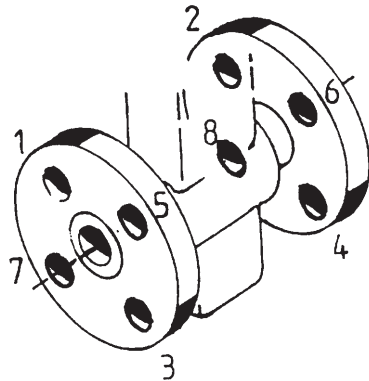

6 Limits

Connections	Connection meter size	Max. operating pressure in bar/psig at product temperature of ...							
		< 40°C (< 105°F)	< 60°C (< 140°F)	< 70°C (< 158°F)	< 90°C (< 195°F)	< 100°C (< 210°F)	< 120°C (< 250°F)	< 140°C ** (< 285°F)	< 180°C ** (< 355°F)
Flange DIN 2501/PN 40	DN 10*-15	39 (566)	37 (537)	36 (522)	34 (493)	33 (479)	32 (464)	30 (435)	28 (406)
Flange JIS 2210/20 K	DN 10*-15	39 (566)	37 (537)	36 (522)	34 (493)	33 (479)	32 (464)	30 (435)	28 (406)
Flange ANSI B 16.5: 150 lb	1/2"*	19.6 (284)	19.0 (276)	18.7 (271)	18.1 (263)	17.7 (257)	17.0 (247)	16.2 (235)	14.7 (213)
	300 lb	1/2"*	39 (566)	37 (537)	36 (522)	34 (493)	33 (479)	32 (464)	30 (435)
Aseptic weld-on connection for pipes to DIN 11 850	DN 10*-40	40 (580)	40 (580)	40 (580)	40 (580)	40 (580)	40 (580)	40 (580)	-
	DN 50-80	25 (360)	25 (360)	25 (360)	25 (360)	25 (360)	25 (360)	25 (360)	-
Aseptic weld-on connection for pipes to ISO 2037	12*-38/1"-1 1/2"	40 (580)	40 (580)	40 (580)	40 (580)	40 (580)	40 (580)	40 (580)	-
	51-76.1/2"-3"	25 (360)	25 (360)	25 (360)	25 (360)	25 (360)	25 (360)	25 (360)	-
Dairy screw connection DIN 11 851	DN 10*-40	40 (580)	40 (580)	40 (580)	40 (580)	40 (580)	40 (580)	40 (580)	-
	DN 50-80	25 (360)	25 (360)	25 (360)	25 (360)	25 (360)	25 (360)	25 (360)	-
Screwed pipe connection ISO 2853	12*-38 mm	40 (580)	40 (580)	40 (580)	40 (580)	40 (580)	40 (580)	40 (580)	-
	51-76.1 mm/1 1/2"-3.0"	25 (360)	25 (360)	25 (360)	25 (360)	25 (360)	25 (360)	25 (360)	-
Screwed pipe connection SMS 1145	25-76 mm	6 (90)	6 (90)	6 (90)	6 (90)	6 (90)	6 (90)	-	-
Clamp joint ISO 2852	12*-51 mm/1 1/2"-2.0"	16 (230)	16 (230)	16 (230)	16 (230)	16 (230)	16 (230)	-	-
	63.5-76.1 mm/2 1/2"-3.0"	10 (150)	10 (150)	10 (150)	10 (150)	10 (150)	10 (150)	-	-
Vacuum load	all sizes	0 mbar abs.							

* size DN 2.5 - 10 / 1/10" - 3/8"

** max. process temperature 140°C (285°F) for compact flowmeters
ambient temperature here max. 40°C/104°F.

7. Grounding

- **Warning:** All flowmeters must be properly grounded to avoid personnel shock hazard.
- The ground conductor should not transmit any interference voltages, therefore do not ground any other electrical devices together with this conductor.

Separate primary head IFS 6000 F with terminal box

- A **functional ground FE** must always be connected.
- **Signal converters with a field power supply of > 125 mA / > 60 V:**
Because of the higher field current from the signal converter, a **PE protective conductor** must be connected to the IFS 6000 F primary head, see grounding diagrams.

Compact systems

Supply power > 50 V AC

- Grounding is via the **PE protective ground conductor** incorporated in the power supply cable, see also Section "Connection to power" in the installation and operating instructions for the signal converter.
- **EXCEPTION: Do not connect up the PE protective ground conductor in the terminal box** if e.g. compact units are operated in the proximity of electric furnaces, electrolysis plants, etc., and large potential differences occur in the pipeline system. An FE functional ground must simultaneously take over the function of the protective conductor (combined protective/functional ground). Refer to appropriate national codes for specific requirements for this type of installation, which may require the addition of a ground fault detection circuit interrupter.

Power supply 24 V AC or DC

- Protective separation (PELV) must be ensured (VDE 0100/VDE 0106 or IEC 364/IEC 536 or equivalent national regulations).
- An **FE functional ground conductor** must be connected for measurement reasons.

Grounding diagrams

Flowmeter with flange connections and grounding rings

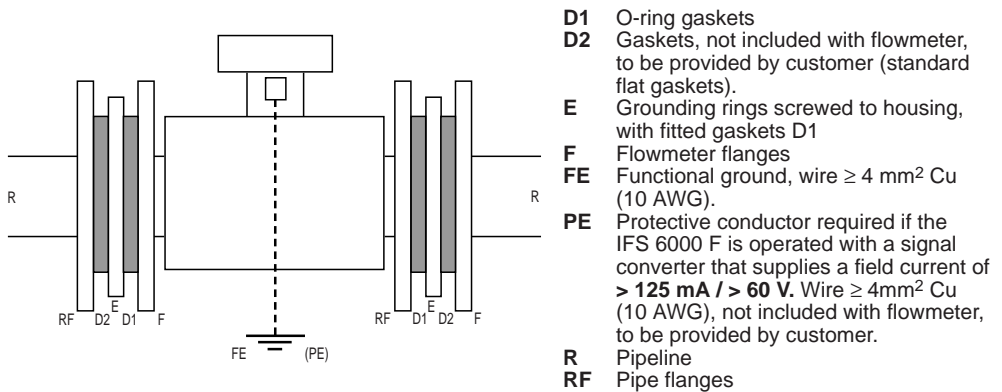

Flowmeter with adapters

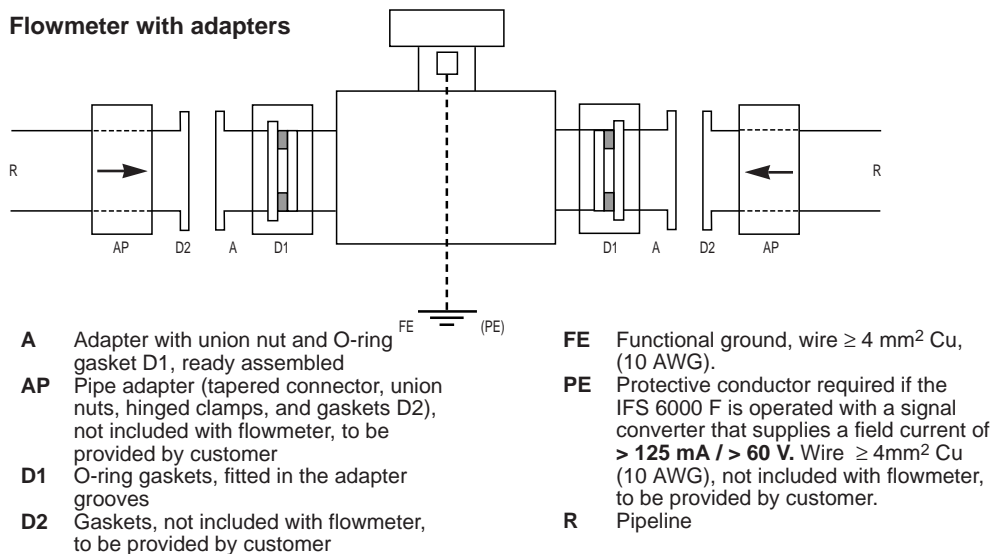

8 Service

8.1 Replacement of the separate primary head

Switch off power source before commencing work!

- 1) Note down terminal assignment before dismantling the "old" primary head.
- 2) Install the new primary head as described in the supplied installation instructions.
- 3) Make electrical connection at the signal converter as described in the installation and operating instructions for the signal converter.
- 4) Specific calibration data are defined during factory calibration for each primary head, which are indicated on the instrument nameplate.
This includes the primary constant GK and the magnetic field frequency. These data need to be reset in the signal converter.
- 5) If the size of primary head is also different from the old one, the full-scale range $Q_{100\%}$ and the meter size will need to be reset.
- 6) After resetting the signal converter, carry out a zero point check.
- 7) If necessary, reset the internal electronic totalizer of the signal converter.

8.2 Replacement of O-ring gaskets with adapters

- Unscrew union nuts.
Caution: keep hold of the flowmeter to prevent it from dropping out of the pipeline.
- Remove the flowmeters from the pipeline.
- Remove O-rings (gaskets D1, see grounding diagram in Sect. 7) from the adapter grooves.
- Apply grease to new gaskets D1 (Paraliq GTE 703, Silubin or Similar).
- Insert O-rings into the adapters.
- Slide the flowmeter between the adapters.
- Tighten union nuts down to metal stop.

- 1 flowmeter
2 O-ring
3 adapter
4 union nut

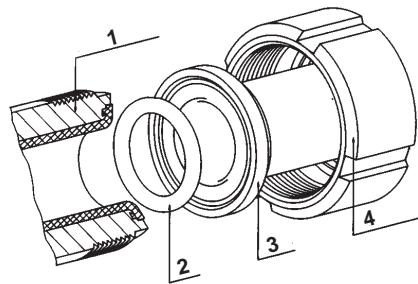

9 Spare parts and order numbers

O-ring gaskets D1 between coupler and measuring tube

Material: EPDM, FDA-approved
(Gasket arrangement, see Sect. 7)

Meter size		Order No.
mm	inch	
2.5	1/10	5.30001.03
4	1/6	5.30001.04
6	1/4	5.30001.05
10	3/8	5.31116.02
15	1/2	5.31116.03
25 DIN	–	5.30026.03
25 ISO	1 ISO	5.30026.06
40 DIN	–	5.30034.03
40 ISO	1 1/2 ISO	5.30034.04
50 DIN	–	5.30038.03
50 ISO	2 ISO	5.30038.03
65 DIN	–	5.30034.06
65 ISO	3 ISO	5.30034.04
80 DIN	–	5.30034.09
80 ISO	4 ISO	5.30034.05

O-ring gaskets D1 between measuring tube and grounding rings

(gasket arrangement, see Sect. 7)

Meter size		Material	Order No.
DN 2.5 - 15	1/10" - 1/2"	Viton	5.30014.02
		Kalrez	5.30014.03
		EPDM	5.30014.04

10 Technical data

Size/type	DN 2.5 - 80 and 1/10" - 3"
Available connections	see page 3
Electrical conductivity	≥ 5 μS/cm (≥ 20 μS/cm for demineralized water)
Ambient temperature	
Standard	-25 to +60 °C / -13 to +140 °F
Hazardous duty versions	-20 to +40 °C / - 4 to +104 °F
Max. permissible operating data	
Operating pressure / product temperature	see table "limits" on next page
Vacuum load	0 mbar abs. / 0 psia
Insulation class of field coils	H
Electrode design	permanently fitted (≥ DN 25 / ≥ 1" surface polished)
Power for field coils	> 60 V from signal converter
Grounding rings	standard for flanged connections
Protection category (IEC 529/EN 60 529)	IP 67, equivalent to NEMA 6
Materials	
<u>Measuring tube</u>	stainless steel 1.4301 / 304-AISI
<u>Liner</u>	clear, virgin Teflon®-PFA, FDA-approved
DN 2.5 - 10 mm / 1/10" - 3/8"	reinforced with sintered metal bearing bush
DN 15 - 80 mm / 1/2" - 3"	reinforced with stainless steel mesh
<u>Electrodes</u>	
Standard	Hastelloy C4
Special version	stainless steel 1.4571/316 Ti-AISI, titanium, tantalum, platinum others on request
<u>Connections</u>	
Flanges to DIN 2501	} Standard: stainless steel 1.4301/304-AISI } Special version: stainless steel 1.4404/316L-AISI
ANSI B 16.5	
JIS 2210	
Aseptic weld-on connection for pipes to DIN 11 850 ISO 2037	} stainless steel 1.4404/316L-AISI
Dairy screw connection and tube nozzles (option) to DIN 11 851	
Screwed pipe connection to SMS 1145	
Screwed pipe connection to ISO 2853	
Clamp joint to ISO 2852	
<u>Housing</u>	
DN 2.5 - 15 mm / 1/10" - 1/2"	stainless steel 1.4462 Duplex
DN 25 - 80 mm / 1" - 3"	stainless steel 1.4301/304-AISI
<u>Terminal box</u>	
Standard	die cast aluminium, paint finish
Special version	stainless steel 1.4301/304-AISI, others on request
<u>Grounding rings (only for flange versions)</u>	stainless steel 1.4571/316 Ti-AISI, others on request

Teflon® is a registered trademark of Du Pont

11 Dimensions and weights

PLEASE NOTE

The **total dimension for the height** is obtained from **dimension b** (see table) **plus the height** of the terminal box or the signal converter, see drawings.

The **total weight** is made up of the weight of the signal converter (see table) **plus** the weight of the terminal box or signal converter, see below.

Terminal box

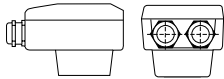

Weight approx.
0.5 kg (1.1 lb)

IFC 010 K and IFC 020 K
signal converter

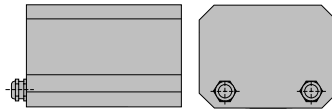

Weight approx.
1.6 kg (3.6 lb)

IFC 090 K signal converter

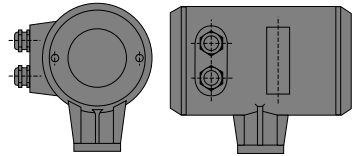

Weight approx.
2.3 kg (5.1 lb)

Flange connections to DIN, JIS and ANSI

Flowmeter		Dimensions in mm and (inch)								Approx. weight in kg (lb)	
Size/type	Flanges	a	b _{max}	ØD				d			
DIN/JIS	ANSI	DIN/JIS	ANSI	DIN/PN 40	JIS/20 K	ANSI/150 lb	ANSI/300 lb				
DN 2.5	1/10"										
DN 4	1/8"										
DN 6	1/4"	DN 10	1/2"	130 (5.12)	142 (5.59)	90 (3.54)	90 (3.54)	88.9 (3.50)	95.2 (3.75)	51 (2.01)	2.6 (5.8)
DN 10	3/8"										
DN 15	1/2"	DN 15				95 (3.74)	95 (3.74)				

DN 2.5 - 15 / 1/10" - 1/2"

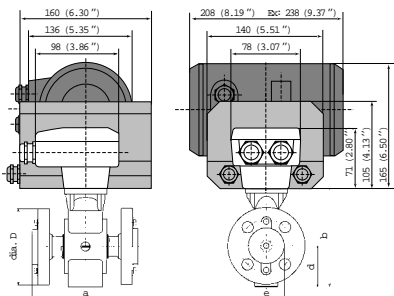

(Continuation see next page)

Dimensions without connectors/adapters

Size/type		Dimensions in mm				Approx. weight in kg (lb) without adapters
mm	inch	L _M	b _{max}	d	e	
DN 2.5	1/10	180 (7.09)	142 (5.59)	51 (2.01)	44 (1.73)	1.2 (2.7)
DN 4	1/8					
DN 6	1/4					
DN 10	3/8					
DN 15	1/2					
DN 25	1	186 (7.32)	146 (5.75)	40 (1.57)	80 (3.15)	1.8 (4.0)
DN 40	1 1/2	200 (7.87)	164 (6.46)	49 (1.93)	98 (3.86)	3.2 (7.1)
DN 50	2	204 (8.03)	196 (7.72)	65 (2.56)	130 (5.12)	4.5 (10.0)
DN 65	2 1/2	250 (9.84)	221 (8.70)	78 (3.07)	156 (6.14)	7.0 (15.5)
DN 80	3	266 (10.47)				

DN 2.5 - 15 / 1/10" - 1/2"

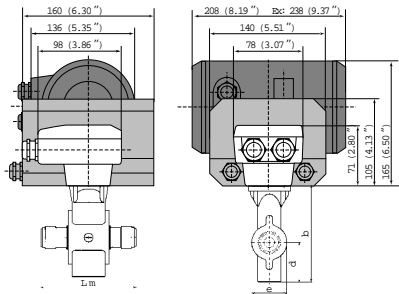

DN 25 - 80 / 1" - 3"

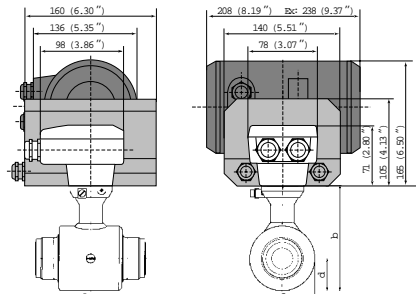

Dimensions with mounted connectors/adapters (1)

Aseptic weld-on connection for pipes to DIN 11 850

Connection meter size	dia. D	L _A	a	dia. D1	dia. D2	dia. D3
DN 10 ¹⁾	38 (1.50)	30.0 (1.18)	180 (7.09)	10 (0.39)	12 (0.47)	15 (0.59)
DN 15				16 (0.63)	18 (0.71)	21 (0.83)
DN 25	63 (2.48)	25.0 (0.98)	186 (7.32)	26 (1.02)	28 (1.10)	31 (1.22)
DN 40	78 (3.07)	23.0 (0.91)	200 (7.87)	38 (1.50)	40 (1.57)	43 (1.69)
DN 50	92 (3.62)	22.0 (0.87)	204 (8.03)	50 (1.97)	52 (2.05)	55 (2.17)
DN 65	112 (4.41)	21.0 (0.83)	250 (9.84)	66 (2.60)	68 (2.68)	72 (2.83)
DN 80	127 (5.00)	29.0 (1.14)	266 (10.47)	81 (3.19)	83 (3.27)	87 (3.43)

Aseptic weld-on connection for pipes to ISO 2037

Connection meter size	dia. D	L _A	a	dia. D1	dia. D2	dia. D3
12 mm ¹⁾	—	38 (1.50)	180 (7.09)	10.0 (0.39)	12.0 (0.47)	15.0 (0.59)
18 mm	—			16.0 (0.63)	18.0 (0.71)	21.0 (0.83)
25 mm	1 ²⁾	63 (2.48)	22.0 (0.87)	22.6 (0.89)	—	25.6 (1.01)
38 mm	1 1/2"	78 (3.07)	26.5 (1.04)	207 (8.15)	35.6 (1.40)	—
51 mm	2"	92 (3.62)	28.5 (1.12)	217 (8.54)	48.6 (1.91)	—
63.5 mm	2 1/2"	112 (4.41)	27.5 (1.08)	263 (10.35)	60.3 (2.37)	—
76.1 mm	3"	127 (5.00)	—	72.9 (2.87)	—	76.7 (3.02)

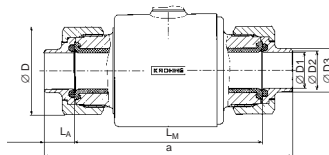

1) for sizes DN 2.5 - 10 / 1/10" - 3/8"

2) not to ISO 2037

(Continuation see next page)

Dimensions with mounted connectors/adapters (2)

Dairy screw connection to DIN 11851

Connection meter size	dia. D	L _A	a
DN 10 ¹⁾	38 (1.50)	47.0 (1.85)	214 (8.43)
DN 15			
DN 25	63 (2.48)		230 (9.06)
DN 40	78 (3.07)	49.0 (1.93)	252 (9.92)
DN 50	92 (3.62)	50.0 (1.97)	260 (10.24)
DN 65	112 (4.41)	53.0 (2.09)	314 (12.36)
DN 80	127 (5.00)	66.0 (2.60)	340 (13.39)

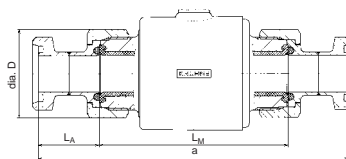

Screwed pipe connection to ISO 2853

Connection meter size	dia. D	L _A	a
12 mm ¹⁾	38 (1.50)	53.0 (2.09)	226 (8.90)
18 mm			
25 mm	63 (2.48)	45.0 (1.77)	
38 mm	1 1/2"	78 (3.07)	49.5 (1.95)
51 mm	2"	92 (3.62)	51.5 (2.03)
63.5 mm	2 1/2"	112 (4.41)	50.5 (1.99)
76.1 mm	3"	127 (5.00)	309 (12.17)

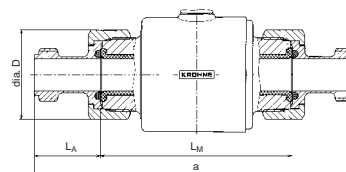

Screwed pipe connection to SMS 1145

Connection meter size	dia. D	L _A	a
25 mm ¹⁾	63 (2.48)	38.5 (1.52)	213 (8.39)
38 mm	78 (3.07)	48.0 (1.89)	250 (9.84)
51 mm	92 (3.62)	50.0 (1.97)	260 (10.24)
63.5 mm	112 (4.41)		314 (12.36)
76 mm	127 (5.00)	53.0 (2.09)	

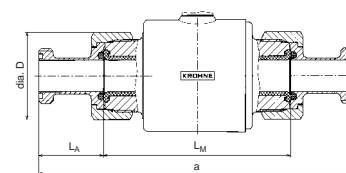

Clamp joint ISO 2852

Connection meter size	dia. D	L _A	a
12 mm ¹⁾	38 (1.50)	49.5 (1.95)	219 (8.62)
18 mm			
25 mm	63 (2.48)	45.0 (1.77)	226 (8.90)
38 mm	1 1/2"	78 (3.07)	49.5 (1.95)
51 mm	2"	92 (3.62)	51.5 (2.03)
63.5 mm	2 1/2"	112 (4.41)	50.5 (1.99)
76.1 mm	3"	127 (5.00)	309 (12.17)

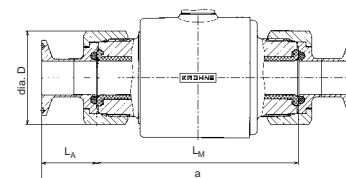

1) for sizes DN 2.5 - 10 / 1/10" - 3/8"

If you need to return flowmeters for testing or repair to Krohne

Your electromagnetic flowmeter

- has been carefully manufactured and tested by a company with ISO 9001 certification
- and volumetrically calibrated in one of the world's most accurate test rigs.

If installed and operated in accordance with these operating instructions, your flowmeter will rarely present any problems.

Should you nevertheless need to return a flowmeter for checkout or repair, please pay strict attention to the following points:

Due to statutory regulations concerning protection of the environment and the health and safety of our personnel, Krohne may only handle, test and repair returned flowmeters that have been in contact with liquids if it is possible to do so without risk to personnel and environment. This means that Krohne can only service your flowmeter if it is accompanied

by a certificate in line with the following model confirming that the flowmeter is safe to handle.

If the flowmeter has been operated with toxic, caustic, flammable or water-endangering liquids, you are kindly requested

- to check and ensure, if necessary by rinsing or neutralizing, that all cavities in the flowmeter are free from such dangerous substances.
(Directions on how you can find out whether the primary head has to be opened and then flushed out or neutralized are obtainable from Krohne on request.)
- to enclose a certificate with the flowmeter confirming that the flowmeter is safe to handle and stating the liquid used.

Krohne regret that they cannot service your flowmeter unless accompanied by such a certificate.

SPECIMEN certificate

Company:

Address:

Department:

Name:

Tel. No.:

The enclosed electromagnetic flowmeter

Type:

Krohne Order No. or Series No.:

has been operated with the following liquid:

Because this liquid is

water-endangering * / toxic * / caustic * / flammable *

we have

– checked that all cavities in the flowmeter are free from such substances *

– flushed out and neutralized all cavities in the flowmeter *

(* delete if not applicable)

We confirm that there is no risk to man or environment through any residual liquid contained in this flowmeter.

Date: Signature:

Company stamp: