

Operating Instructions

SU 600 Ex

4 ... 20 mA signal conditioning instrument



Variable area flowmeters

Vortex flowmeters

Flow controllers

Electromagnetic flowmeters

Ultrasonic flowmeters

Mass flowmeters

Level measuring instruments

Communications engineering

Engineering systems & solutions

Switches, counters, displays and recorders

Heat metering

Pressure and temperature

Contents

1	About this document	
1.1	Function	4
1.2	Target group	4
1.3	Symbolism used	4
2	For your safety	
2.1	Authorised personnel	5
2.2	Appropriate use	5
2.3	Warning about misuse	5
2.4	General safety instructions	5
2.5	CE conformity	5
2.6	Safety information for Ex areas	6
3	Product description	
3.1	Configuration	7
3.2	Principle of operation	7
3.3	Adjustment	8
3.4	Storage and transport	8
4	Mounting	
4.1	General instructions	9
4.2	Mounting information	9
5	Connecting to power supply	
5.1	Preparing the connection	11
5.2	Connection procedure	11
5.3	Wiring plan	13
6	Setup with the integrated indicating and adjustment unit	
6.1	Adjustment system	15
6.2	Setup procedure	16
6.3	Application example	20
7	Maintenance and fault rectification	
7.1	Maintenance	23
7.2	Fault rectification	23
7.3	Instrument repair	24
8	Dismounting	
8.1	Dismounting procedure	25
8.2	Disposal	25

9 Supplement

9.1	Technical data	26
9.2	Dimensions	29
9.3	Certificate	30

1 About this document

1.1 Function

This operating instructions manual has all the information you need for quick setup and safe operation of SU 600 Ex. Please read this manual before you start setup.

1.2 Target group

This operating instructions manual is directed to trained personnel. The contents of this manual should be made available to these personnel and put into practice by them.

1.3 Symbolism used



Information, tip, note

This symbol indicates helpful additional information.



Caution, warning, danger

This symbol informs you of a dangerous situation that could occur. Ignoring this cautionary note can impair the person and/or the instrument.



Ex applications

This symbol indicates special instructions for Ex applications.



List

The dot set in front indicates a list with no implied sequence.



Action

This arrow indicates a single action.



Sequence

Numbers set in front indicate successive steps in a procedure.

2 For your safety

2.1 Authorised personnel

All operations described in this operating instructions manual must be carried out only by trained specialist personnel authorised by the operator. For safety and warranty reasons, any internal work on the instruments must be carried out only by personnel authorised by the manufacturer.

2.2 Appropriate use

SU 600 Ex is a universal signal conditioning instrument and power supply unit for connection of a 4 ... 20 mA/HART sensor.

2.3 Warning about misuse

Inappropriate or incorrect use of the instrument can give rise to application-specific hazards, e.g. vessel overfill or damage to system components through incorrect mounting or adjustment.

2.4 General safety instructions

SU 600 Ex is a high-tech instrument requiring the strict observance of standard regulations and guidelines. The user must take note of the safety instructions in this operating instructions manual, the country-specific installation standards (e.g. the VDE regulations in Germany) as well as all prevailing safety regulations and accident prevention rules.

2.5 CE conformity

SU 600 Ex is in CE conformity with EMC (89/336/EWG) and NSR (73/23/EWG).

Conformity has been judged acc. to the following standards:

- EMC:
 - Emission DIN/EN 61326: 2004
 - Susceptibility DIN/EN 61326: 2004 incl. supplement A
- NSR: EN 61010-1: 2001

2.6 Safety information for Ex areas

Please note the Ex-specific safety information for installation and operation in Ex areas. These safety instructions are part of the operating instructions manual and come with the Ex-approved instruments.

3 Product description

3.1 Configuration

Scope of delivery

The scope of delivery encompasses:

- Indicating and signal conditioning instrument SU 600 Ex
- Mounting set
- Ex separating chamber
- Identification label
- Documentation
 - this operating instructions manual
 - Ex specific safety instructions and, if necessary, further certificates.

Overview

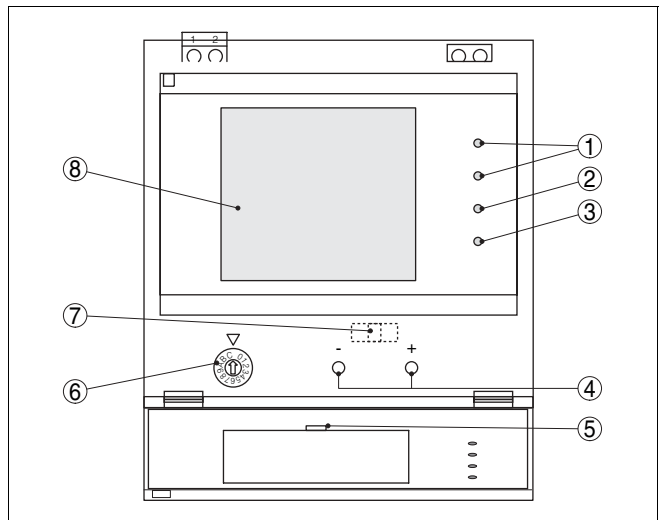

Fig. 1: SU 600 Ex

- 1 Status indications operating relay 1 and 2
- 2 Status indication fail safe relay
- 3 Status indication operation
- 4 [+/-] adjustment keys
- 5 Insertable tag for identification of the measurement loop
- 6 Function switch
- 7 Mode switch for sensor input (active/passive) on the rear of the instrument
- 8 LC display

3.2 Principle of operation

Area of application

SU 600 Ex is a universal single signal conditioning instrument with integrated level switches and display for continuously measuring sensors. At the same time, it can serve as power

supply unit for connected sensors. SU 600 Ex is designed for connection of an individual 4 ... 20 mA sensor. The instrument is suitable for carrier rail, panel and surface mounting.

Physical principle

SU 600 Ex signal conditioning instrument can power the connected sensor and also evaluate its measurement signals. The requested parameter is indicated in the display and, in addition, outputted to the integrated current output for further processing. Hence the measuring signal can be transmitted to a remote display or a connected control system. In addition, two level relays for control of pumps or other actuators are integrated.

Power supply

Wide-range power supply unit with 20 ... 253 V AC/DC for world-wide use.

You will find detailed information on the power supply in the "Technical data" in the "Supplement".

3.3 Adjustment

The adjustment of SU 600 Ex is carried out via the integrated keys and a 16-step function switch.

3.4 Storage and transport

Packaging

Your instrument was protected by packaging during transport. Its capacity to handle normal loads during transport is assured by a test acc. to DIN EN 24180.

The packaging of standard instruments consists of environment-friendly, recyclable cardboard. For special versions PE foam or PE foil is also used. Dispose of the packaging material via specialised recycling companies.

Storage and transport temperature

- Storage and transport temperature see "Supplement – Technical data – Ambient conditions"
- Relative humidity 20 ... 85 %

4 Mounting

4.1 General instructions

Installation location

You can mount the SU 600 Ex signal conditioning instrument onto a carrier rail 35x7.5 acc. to DIN EN 50022, or directly on the wall by means of the three screws or in a front panel or door of a switching cabinet.



Note:

Before mounting SU 600 Ex, set the requested mode of the measuring data input. With a slide switch on the rear of the instrument you can choose between active and passive current input (see also chapter " *Connecting to power supply* "). After mounting the instrument, the slide switch is no longer accessible.

4.2 Mounting information

Carrier rail mounting

- 1 Place the adapter plate [1] to the rear of SU 600 Ex (spring of the adapter plate downward) and fasten the plate with screw [2] (M4x6).
- 2 Place SU 600 Ex against the carrier rail [3] from below and push the instrument upward until it snaps in.

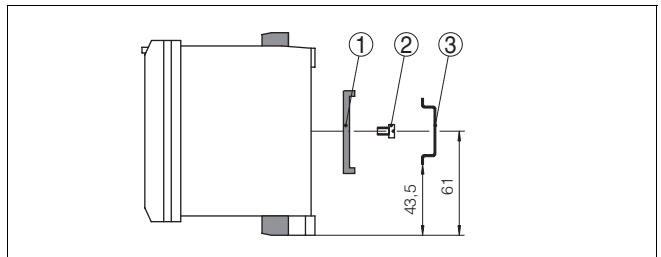

Fig. 2: Carrier rail mounting

- 1 Adapter plate
- 2 Screw (M4x6)
- 3 Carrier rail

Wall mounting

- 1 Insert the metal strap [1] from above into the housing cut-out.
- 2 Fasten the instrument directly to the wall with the three screws (\varnothing max. 4 mm).

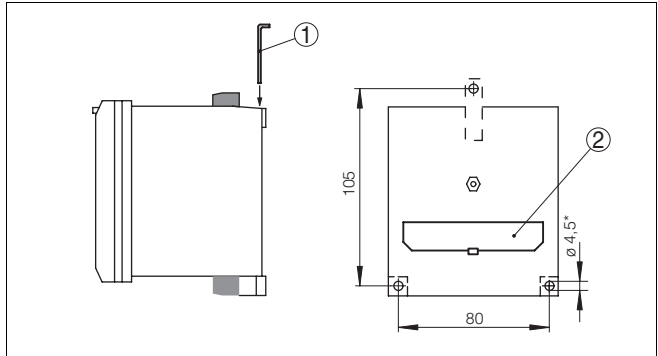

Fig. 3: Wall mounting

- 1 Metal strap
- 2 Covering slide switch active-passive

Panel mounting

- 1 Remove the pluggable terminal strips from the top and bottom.
- 2 Screw pin [3] into the rear of SU 600 Ex and tighten with a screwdriver.
- 3 Insert SU 600 Ex from the front into the front panel [1].
- 4 Place the clamping strap [2] from the back over the pin [3] and pull it with the knurled nut [4] against the panel [1].

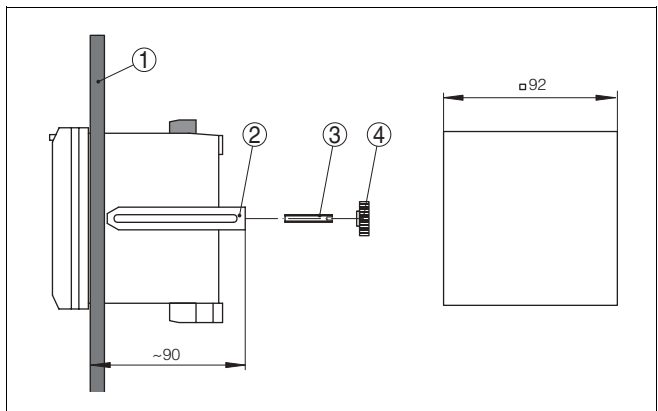

Fig. 4: Panel mounting

- 1 Front panel
- 2 Terminal strap
- 3 Pin
- 4 Knurled nut

5 Connecting to power supply

5.1 Preparing the connection

Note safety instructions

Always observe the following safety instructions:

- Connect only in the complete absence of line voltage
- If overvoltages are expected, overvoltage arresters should be installed.

Take note of safety instructions for Ex applications



In hazardous areas you should take note of the appropriate regulations, conformity and type approval certificates of the sensors and power supply units.

Select power supply

The power supply can be 20 ... 253 V AC, 50/60 Hz or 20 ... 253 V DC.

Select connection cable

Power supply of SU 600 Ex is connected with standard cable acc. to the national installation standards.

Standard two-wire cable without screening can be used to connect sensors. If electromagnetic interference is expected, screened cable must be used.

Cable screening and grounding

Connect the cable screen on both ends to ground potential. In the sensor, the screen must be connected directly to the internal ground terminal. The ground terminal outside on the sensor housing must be connected to the potential equalisation.

If potential equalisation currents are expected, the screen connection on SU 600 Ex must be made via a ceramic capacitor (e.g. 1 nF, 1500 V). The low frequency potential equalisation currents are thus suppressed, but the protective effect against high frequency interference signals remains.

Select connection cable for Ex applications



Take note of the corresponding installation regulations for Ex applications. In particular, make sure that no potential equalisation currents flow over the cable screen. In case of grounding on both sides this can be achieved by the use of a capacitor or a separate potential equalisation.

5.2 Connection procedure

Proceed as follows:

- 1 Mount SU 600 Ex

- 2 Connect sensor cable to terminal 1 and 2, and where applicable, connect the screen
- 3 Connect power supply (switched off) to terminal 5 and 6
- 4 Where applicable, connect fail safe and operating relay as well as current output

The electrical connection is finished.



After connection, it is absolutely necessary to plug the blue Ex separating chamber to terminals 1 and 2 (sensor input). This ensures the required distance of at least 50 mm (1.97 in) to other instruments.

- 1 Place the Ex separating chamber as shown below on the terminals of the sensor input
- 2 Lead the sensor cable towards the front and out of the Ex separating chamber
- 3 Push the Ex separating chamber towards the front until you hear it snap in

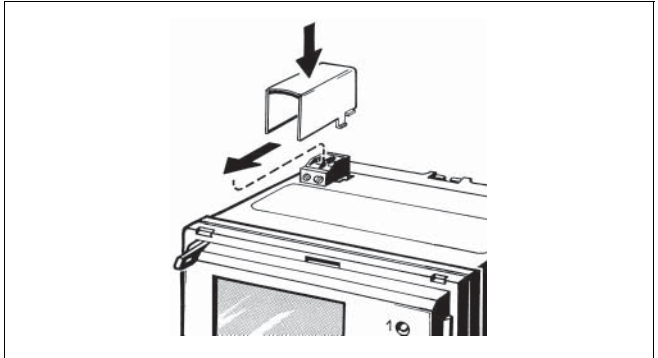

5.3 Wiring plan

Overview

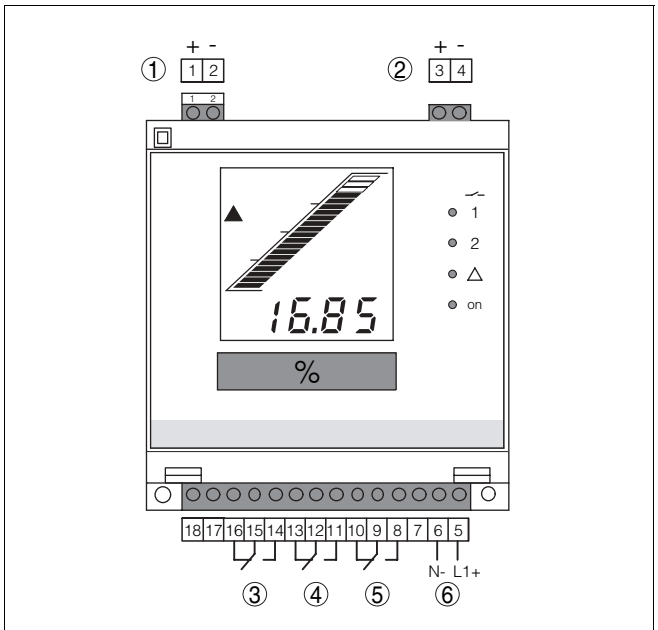

Fig. 5: Terminal assignment SU 600 Ex

- 1 Measurement data input, optionally available with sensor power supply
- 2 Current output
- 3 Fail safe relay
- 4 Relay 2
- 5 Relay 1
- 6 Power supply

**Information:**

Via the slide switch on the rear of the instrument you can switch over between active and passive operation of the measuring data input:

- In active mode, SU 600 Ex provides the power for the connected sensors. Power supply and measurement data are transmitted over the same two-wire cable. This mode is provided for connection of transmitters without separate power supply (sensors in two-wire version).
- In passive mode, the sensors are not powered - only the measured value is transmitted. This input is for transmitters with their own separate power supply (sensors in four-wire version). Furthermore, SU 600 Ex can be connected to an existing circuit like a standard current meter.



The position of the slide switch also influences the preconditions for Ex implementation. Take note of the type approval certificate or the conformity certificate of SU 600 Ex.

6 Setup with the integrated indicating and adjustment unit

6.1 Adjustment system

The integrated indicating and adjustment unit is for measured value display, adjustment and diagnosis of SU 600 Ex. Indication and adjustment is carried out in the front via a clear LC-display and a function switch as well as two keys.

To open the cover, insert a screwdriver in the two slots on the top and turn it slightly.

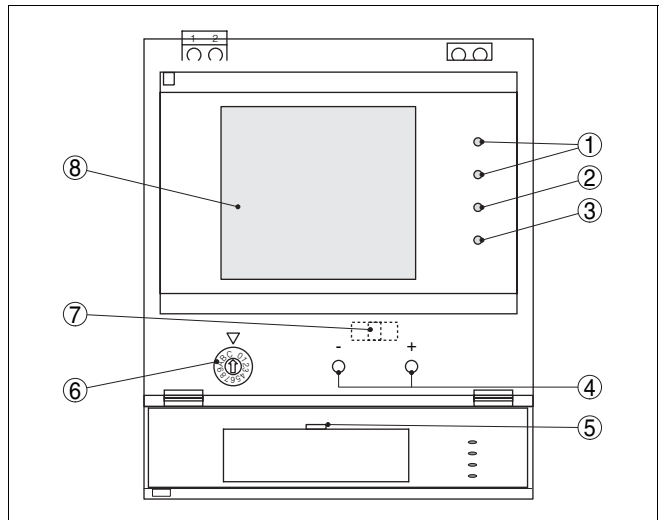

Fig. 6: Indicating and adjustment elements

- 1 Status indications operating relay 1 and 2
- 2 Status indication fail safe relay
- 3 Status indication operation
- 4 [+/-] adjustment keys
- 5 Insertable tag for identification of the measurement loop
- 6 Function switch
- 7 Mode switch for sensor input (active/passive) on the rear of the instrument
- 8 LC display

Key functions

- **[Function switch]** for selection of:
 - Adjustment
 - Relay switching points
 - Scaling
 - Current output
 - Integration time
 - Offset correction
- **[+/-]** key:
 - Change value of the parameter

By pushing the [+/-] key, you change the individual parameters of the selected function. In this phase, the processed parameter is flashing. By briefly pushing the two keys simultaneously, you save your settings. "Save" is briefly displayed.

6.2 Setup procedure

Set up

Setup encompasses mainly the adjustment of the measurement loop. A scaling of the measured value for the LC display and the adaptation of the relay switching points are additional settings. Additional setup steps might be, if necessary, setting an integration time to smooth the measured value or modifying the current output characteristics.

To clearly denote the measuring unit, the supplied labels can be inserted in the cover. In case several SU 600 Ex are used, each measurement loop should be clearly labelled.

Switch on phase

After being switched on, SU 600 Ex first of all carries out a short self-check. The following steps are carried out:

- Internal check of the electronics
- indication of the firmware version
- the output signal jumps briefly to the set fault current

Then the actual measured value is displayed and the corresponding current is transmitted to the current output.

Measured value indication

The measured value indication shows the digital indication value and also an analogue bargraph. Here, it is absolutely necessary that the function switch is set to position [0] ("OPERATE").

Function switch

The following functions can be selected via the rotary switch:

- **0:** Measured value display and simulation
- **1:** Relay 1 switching point ON
- **2:** Relay 1 switching point OFF

- **3:** Relay 2 switching point ON
- **4:** Relay 2 switching point OFF
- **5:** Decimal point position of the scaling
- **6:** Scaling for 100 %
- **7:** Scaling for 0 %
- **8:** Switch over current output 0/4 ... 20 mA
- **9:** Damping of the measured value (integration time)
- **A:** Offset correction
- **B:** Min. adjustment in % by modifying the level
- **C:** Max. adjustment in % by modifying the level
- **D:** Min. adjustment in mA without modifying the level
- **E:** Max. adjustment in mA without modifying the level
- **F:** No function

Offset correction

When a pressure transmitter is used, an offset correction should be carried out first. These instruments are factory-set in a certain position. If the pressure transmitter is now mounted in a different position, its measuring range is shifted slightly. The zero point is readjusted by carrying out the offset correction in uncovered (unpressurised) condition. The complete measuring range will be shifted by the deviating amount.

- Make sure that the pressure transmitter is completely unpressurised, uncovered (unimmersed) and mounted in its final position.
- Set the function switch to position [**A**]. The display indicates now the actual sensor current in mA. Save the current status by pushing the [+/-] keys simultaneously.

Adjustment in mA without changing the level

For this adjustment procedure, two sensor current values (4 ... 20 mA) must be entered corresponding to the levels 0 % and 100 %.

When using a pressure transmitter, an offset correction should be carried out to reach maximum accuracy. Carry out this offset correction before adjustment and with the sensor uncovered (unimmersed).

- Select now position [**D**] or [**E**] on the function switch, enter the current values in mA for min. or max. adjustment and save your settings.

Adjustment in % by changing the level

During this adjustment procedure, the current level is assigned to a certain percentage value. For this reason, percentage values that correspond to the actual filling levels must be entered for the min. and max. adjustment. The ideal calibration is at 0 % and 100 %. Because it is not always possible to empty or fill a vessel completely, any value can of course be

entered. The greater the difference between the two adjustment points, the more precise the measurement. It does not matter which value is entered first.

→ Select position [**B**] or [**C**] on the function switch, enter the percentage values for the min. and max. adjustment and save your settings.

Relay outputs

Two operating relays are integrated in SU 600 Ex for level detection. First of all, determine at which switching points the relays should switch on and off again. Furthermore you have to distinguish between the relay modes overflow and dry run protection. You switch over by exchanging the ON/OFF values of the relay.

- **Overflow protection:** Relay is switched off when the max. level is exceeded (safe currentless condition), relay is switched on again when the level falls below the min. level (switch on point < switch off point).
 - **Dry run protection:** Relay is switched off when the level falls below the min. level (safe currentless condition), relay is switched on again when the max. level is exceeded (switch on point > switch off point).
- To adjust the on and off switching points of relay 1, set the function switch to position [**1**] or [**2**], enter the switching points for ON or OFF and save your settings. If necessary, proceed in the same way with relay 2 (position [**3**] or [**4**]).

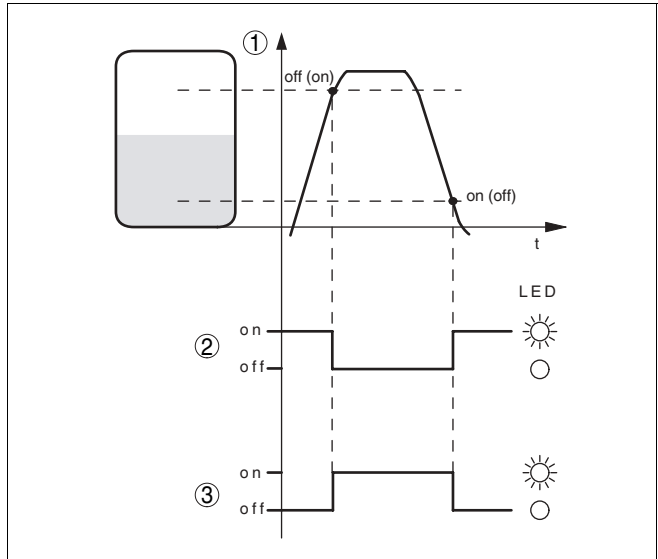

- 1 Level
- 2 Mode overfill protection
- 3 Mode dry run protection

Scaling

Scaling is the conversion of the measured value into a certain parameter or measuring unit. Instead of the percentage value, the volume can be displayed, e.g. in l. Indicating values between max. -9999 and +9999 are possible.

- First of all, determine the max. indicating range and the number of decimal places after the decimal point -- max. four decimal places can be displayed. Select position [5] of the function switch, place the decimal point in the required position and save your settings.
- Now select position [6] or [7] on the function switch, enter the requested values for 100 % or 0 % and save your settings.

Damping

To suppress fluctuation in the measured value display, e.g. caused by an agitated product surface, an integration time can be set. This time can be between 0 and 250 seconds. Keep in mind that this setting will increase the reaction time of the measurement, and that the reaction to quick changes of the measured value will be delayed. In general, a time of a few seconds is sufficient to smooth the measured value display.

→ Now select position [9] on the function switch, enter the requested value and save your settings.

Current output 0/4 ... 20 mA

The characteristics of the current output can be switched over from 4 ... 20 mA to 0 ... 20 mA.

→ Now select position [8] on the function switch, adjust the requested characteristics curve and save your settings.

Simulation

To check if the settings of SU 600 Ex are correct, the simulation mode can be used. Any individual measured value can be simulated and e.g. the correct behaviour of the relays and the connected instruments can be checked.

Switching over between the functions "OPERATE" and "Simulation" is done by pushing the [+/-] keys for at least 3 seconds. In the simulation mode, the set value flashes on the display. The simulation can be switched off by pushing both keys again for approx. 3 seconds. If no key is pushed, the display switches automatically over to "OPERATE" after approx. 60 minutes and the simulation is terminated.

→ To start simulation, push the [+/-] keys simultaneously until the displayed value starts flashing (approx. 3 seconds). By pushing either of the [+/-] keys, you can set the requested simulation value and make your check.

Reset

With a reset, all values set by the user will be lost and are reset to factory settings.

→ Interrupt the power supply of SU 600 Ex. Push the [+/-] keys simultaneously and hold them while you switch on the power supply. The display shows "RES" and the default settings will be restored. These are the following:

- Relay switch on points: 10 %
- Relay switch off points: 100 %
- Decimal point: 888.8
- Display min: 0
- Display max: 100.0
- Integration time: 0 s
- Offset correction: 0
- Current output: 4 ... 20 mA
- Min. adjustment: 0 % or 4 mA
- Max. adjustment: 100 % or 20 mA

6.3 Application example

- An upright cylindrical (linear) tank has a volume of 2700 l

- The max. filling volume is 2650 l, the min. filling volume 50 l
- The level sensor in the vessel is a pressure transmitter (passive), outputting a standardised 4 ... 20 mA signal
- For further processing, an additional 4 ... 20 mA output signal is required
- The full and empty adjustment was carried out directly in the sensor. The following values are outputted:
 - max. volume (display max.) 20 mA = 2650 l
 - min. volume (display min.) 4 mA = 50 l
- Relay 1 should switch on an emptying pump at a level of 90 % and switch off the pump at a level of 10 %

General procedure

- 1 Select the following functions with the rotary switch.
- 2 Push one of the two [+/-] adjustment keys, the digital indication flashes (if the rotary switch is set to "OPERATE", the [+/-] keys are inoperable).
- 3 Adjust the requested value with the [+/-] keys. If you hold the key pushed, the digital indication changes the value more quickly.
- 4 Save your settings by pushing the [+/-] keys simultaneously.

Current output

- Set the function switch to position [8]. Select with the [+/-] keys the measured value output 4 ... 20 mA or 0 ... 20 mA. For this example, choose 4 – 20.

The displayed numbers have the following meanings:

- 0 – 20 = 0 ... 20 mA
- 4 – 20 = 4 ... 20 mA

- Save the value by pushing the [+/-] keys simultaneously.

To scale the indication of SU 600 Ex, the filling volumes for 0 % and 100 %. The vessel does not have to be filled or emptied.

Scaled indication at 0 %

- 1 Set the function switch to position [7] (display min.).
- 2 Set the value to 50 via the [+/-] keys.
- 3 Save the value by pushing both keys simultaneously.

Scaled indication at 100 %

- 1 Set the function switch to position [6] (display max.).
- 2 Set the value to 2650 via the [+/-] keys.
- 3 Save the value by pushing both keys simultaneously.

Decimal point

Because the range of the example vessel is between 50 l to 2650 l, you will need all four positions of the digital indication.

- 1 Set the function switch to position [5] (Decimal Point).
- 2 By pushing the [+/-] keys, you move the decimal point.
- 3 Save the value by pushing both keys simultaneously.

Relay

- Set the function switch to position [1] (relay 1 on). For the given example, select the value 90.0 (90.0 %) with the [+/-] keys. The internal relay 1 then switches on when this value is reached. Save the value by pushing the two keys simultaneously.
- Set the function switch to position [2] (relay 1 off). Select the value 10.0 (10.0 %) with the [+/-] keys. The internal relay 1 then switches off when the value falls below this value. The respective relay control lamp lights when the relay is energized. If the switching points are too close together (<0.1 %), the appropriate LED flashes. The relay takes on the safe condition. In mode "OPERATE " an error message is outputted on the display.
- If you want to control additional relays, proceed in the same way, as with relay 1. The switch positions for setting the respective relays are stated in the list of the function switch under "Setup procedure".

**Note:**

If you want to change the mode (i.e. the switching function of the relays), you have to exchange the On and Off values.

7 Maintenance and fault rectification

7.1 Maintenance

When used as directed in normal operation, SU 600 Ex is completely maintenance-free.

7.2 Fault rectification

Causes of malfunction

SU 600 Ex offers maximum reliability. Nevertheless faults can occur during operation. These may be caused by the following, e.g.:

- Measured value of the sensor not correct
- Power supply
- Interference on the cables

Fault rectification

The first measures to be taken are to check the input/output signals as well as to evaluate the error messages via the display. The procedure is described below. In many cases, the causes can be determined in this way and faults can be rectified.

Fault messages

? E003

- CRC-error
- Carry out a reset
- Return instrument for repair

? E014

- Short-circuit
- Eliminate short-circuit
- If necessary, exchange defective sensor

? E015

- Line break
- Repair sensor cable or replace it
- Check sensor connection

? E016

- Empty/full adjustment reversed
- Carry out a fresh adjustment

? E017

- Adjustment span too small
- Carry out a fresh adjustment and increase the distance between min. and max. adjustment

? E021

- Scaling span too small
- Carry out a fresh scaling, increase the distance between min. and max. scaling.

? E110

- Relay switching points too close together
- Increase the difference between the two relay switching points

7.3 Instrument repair

If a repair is necessary, please proceed as follows:

You can download a return form from our Internet homepage http://www.krohne-mar.com/fileadmin/media-lounge/PDF-Download/Specimen_e.pdf.

By doing this you help us carry out the repair quickly and without having to call back for needed information.

- Print and fill out one form per instrument
- Clean the instrument and pack it damage-proof
- Attach the completed form and possibly also a safety data sheet to the instrument.

8 Dismounting

8.1 Dismounting procedure

**Warning:**

Before dismounting, be aware of dangerous process conditions such as e.g. pressure in the vessel, high temperatures, corrosive or toxic products etc.

Take note of chapters "*Mounting*" and "*Connecting to power supply*" and carry out the listed steps in reverse order.

8.2 Disposal

SU 600 Ex consists of materials which can be recycled by specialised recycling companies. We have purposely designed the electronic modules to be easily separable. Mark the instrument as scrap and dispose of it according to government regulations (electronic scrap ordinance, ...).

Materials: see "*Technical data*"

If you cannot dispose of the instrument properly, please contact us about disposal methods or return.

9 Supplement

9.1 Technical data

General data

Series	instrument for panel or wall mounting or mounting on carrier rail 35x7.5 acc. to EN 50022
Dimensions	W = 96 mm (3.78 in), H = 104 mm (4.09 in), D = 90 mm (3.54 in)
Weight	approx. 400 g (0.88 lbs)
Housing material	plastic ABS/POM
Screw terminals	max. wire cross section 1.5 mm ²

Power supply

Power supply	20 ... 253 V AC, 50/60 Hz, 20 ... 253 V DC
Power consumption	12.4 VA, 4 W

Sensor input

Number of sensors	1x 4 ... 20 mA
Kind of input (switch over)	
– mode active	sensor is powered by SU 600 Ex
– mode passive	sensor has own power supply
Measured value transmission	4 ... 20 mA analogue
Terminal voltage mode active	19.5 ... 14.5 V at 4 ... 20 mA
Current limitation mode active	approx. 30 mA
Inner resistance mode passive	< 250 Ohm
Detection line break	<= 3.6 mA
Detection shortcircuit	>= 21 mA
Adjustment range	
– Empty adjustment	3.8 ... 20.2 mA
– Full adjustment	4.1 ... 20.5 mA
– min. adjustment delta	300 µA
Connection cable	2-wire standard cable (screening recommended)

Relay outputs

Quantity	2x operating relay, 1x fail safe relay
Contact	floating spdt
Contact material	AG NI 0.15 hard gold-plated
Turn-on voltage	min. 10 mV DC, max. 250 V AC/DC
Switching current	min. 10 μ A DC, max. 3 A AC, 1 A DC
Breaking capacitance	min 50 mW, max. 500 VA, max. 54 W DC
Min. switching hysteresis	0.5 %

Current outputs

Quantity	1x output
Range	0/4 ... 20 mA
Resolution	0.1 % or 20 μ A
Max. load	500 Ohm
Fault signal	22 mA
Linearity error	0.1 % (relating to 20 mA)
Temperature error	0.01 %/K (relating to 20 mA)

Displays

Measured value indication	
– LC display (45x45 mm)	digital and quasianalogue indication
– max. indicating range	-9999 ... 9999
LED displays	
– status indication operating voltage	1x LED green
– status indication fault signal	1x LED red
– status indication operating relay 1/2	2x LED yellow

Adjustment

Adjustment elements	2x keys in the front, 1x function switch, 1x slide switch active-passive
---------------------	--

Ambient conditions

Ambient temperature	-20 ... +60°C (-4 ... +140°F)
Storage and transport temperature	-40 ... +80°C (-40 ... +176°F)

Electrical protective measures

Protection	
– Wall/rail mounting	IP 20
– Panel mounting	IP 40

Overvoltage category	II
Protection class	II

Electrical separating measures

Reliable separation acc. to VDE 0106 part 1 between power supply, sensor input and digital part

- Reference voltage 250 V
- insulation resistance 3.75 kV

Galvanic separation between relay output and digital part

- Reference voltage 250 V
- insulation resistance 4 kV

9.2 Dimensions

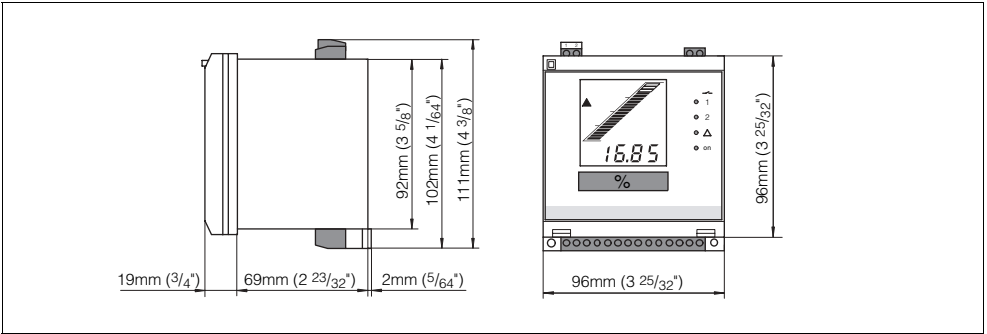

Fig. 7: Dimensions SU 600 Ex

9.3 Certificate

CE declaration of conformity

CE

Konformitätserklärung

Declaration of conformity
Déclaration de conformité

KROHNE

Krohne S.A.S.

Les Ors BP 98
F-26103 Romans Cedex

erklärt in alleiniger Verantwortung, daß das Produkt / declare under
our sole responsibility that our product / déclare sous sa seule
responsabilité que le produit

SU600 Ex

auf das sich diese Erklärung bezieht, mit den folgenden Normen
übereinstimmt / to which this declaration relates is in conformity
with the following standards / auquel se réfère cette déclaration
est conforme aux normes

Emission / Emission / Emission → EN 61326 : 2004 Klasse B
Immission / Susceptibility / Immission → EN 61326 : 2004 einschließlich Anhang A
EN 61010 – 1 : 2001

gemäß den Bestimmungen der Richtlinien / following the provision
of Directives / conformément aux dispositions des Directives

73/23 EWG
89/336 EWG

29.04.2005



i.V./p.p./P.O. Florian Stengele

Fig. 8: CE declaration of conformity

Subject to change without notice