

Operating Instructions

Lock fitting ARV 67 up to 16 bar for OPTISWITCH 3300 C

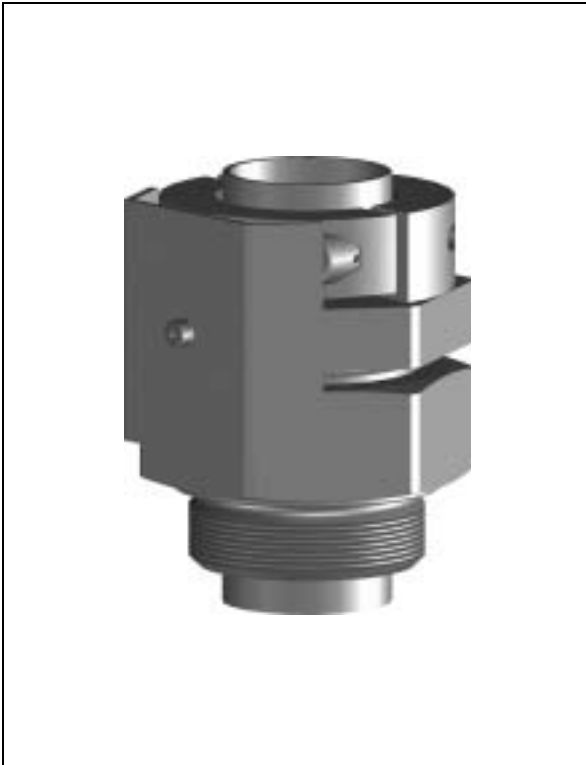

Variable area flowmeters

Vortex flowmeters

Flow controllers

Electromagnetic flowmeters

Ultrasonic flowmeters

Mass flowmeters

Level measuring instruments

Communications engineering

Engineering systems & solutions

Switches, counters, displays and recorders

Heat metering

Pressure and temperature

Contents

1 About this document

1.1	Function	4
1.2	Target group	4
1.3	Symbolism used	4

2 For your safety

2.1	Authorised personnel	5
2.2	Appropriate use	5
2.3	Warning about misuse	5
2.4	General safety instructions	5

3 Product description

3.1	Configuration	6
3.2	Principle of operation	6
3.3	Storage and transport	6

4 Mounting

4.1	General instructions	7
4.2	Mounting procedure	7

5 Maintenance and fault rectification

5.1	Maintenance	10
5.2	Exchange seals	10
5.3	Instrument repair	11

6 Dismounting

6.1	Dismounting procedure	12
6.2	Disposal	12

7 Supplement

7.1	Technical data	13
7.2	Dimensions	14

1 About this document

1.1 Function

This operating instructions manual has all the information you need for quick setup and safe operation of ARV 67. Please read this manual before you start setup.

1.2 Target group

This operating instructions manual is directed to trained personnel. The contents of this manual should be made available to these personnel and put into practice by them.

1.3 Symbolism used



Information, tip, note

This symbol indicates helpful additional information.



Caution, warning, danger

This symbol informs you of a dangerous situation that could occur. Ignoring this cautionary note can impair the person and/or the instrument.



Ex applications

This symbol indicates special instructions for Ex applications.



List

The dot set in front indicates a list with no implied sequence.



Action

This arrow indicates a single action.



Sequence

Numbers set in front indicate successive steps in a procedure.

2 For your safety

2.1 Authorised personnel

All operations described in this operating instructions manual must be carried out only by trained, specialised personnel authorised by the operator. For safety and warranty reasons, any internal work on the instruments must be carried out only by personnel authorised by the manufacturer.

2.2 Appropriate use

ARV 67 is used for for infinite locking with tube extension.

Detailed information on the application range of ARV 67 is available in chapter Product description.

2.3 Warning about misuse

Inappropriate or incorrect use of the instrument can give rise to application-specific hazards, e.g. vessel overfill or damage to system components through incorrect mounting or adjustment.

2.4 General safety instructions

ARV 67 is a high-tech instrument requiring the strict observance of standard regulations and guidelines. The user must take note of the safety instructions in this operating instructions manual, the country-specific installation standards (e.g. the VDE regulations in Germany) as well as all prevailing safety regulations and accident prevention rules.

3 Product description

3.1 Configuration

Scope of delivery

The scope of delivery encompasses:

- Lock fitting ARV 67 for OPTISWITCH 3300 C vibrating level switches
- Documentation
 - this operating instructions manual

3.2 Principle of operation

Area of application

ARV 67 is a pressure-tight threaded fitting up to 16 bar (232 psi) and can be used together with a level sensor in tube version (OPTISWITCH 3300 C). The tube version of the sensor must have a diameter of 43 mm (\varnothing 1.7 in).

The wetted parts of the ARV 67 are made of steel (316L).

Physical principle

With the lock fittings, sensors with tube extension can be fixed infinitely.

The pressure screw of the lock fitting compresses a graphite gasket consisting of three rings axially which is then pressed radially to the tube of the sensor. If mounted correctly, the graphite gasket encircles the tube tightly. The clamp protects the tube against sliding through. A locking bracket protects the terminal screws of the clamp against unauthorised or unintentional loosening.

3.3 Storage and transport

Packaging

Your instrument was protected by packaging during transport. Its capacity to handle normal loads during transport is assured by a test acc. to DIN EN 24180.

The packaging of standard instruments consists of environment-friendly, recyclable cardboard. For special versions, PE foam or PE foil is also used. Dispose of the packaging material via specialised recycling companies.

Storage and transport temperature

- Storage and transport temperature see "*Supplement – Technical data – Ambient conditions*"
- Relative humidity 20 ... 85 %

4 Mounting

4.1 General instructions

The note of the following general safety instructions:

- Dismount the lock fitting only in unpressurized condition
- Use only suitable graphite gasket rings. Make sure that the graphite gasket rings are not damaged. Damaged rings are no longer tight. If you are not sure, use new rings.
- Only use approved hexagon screws DIN 912 M8 x 30 of A4-70 acc. to AD leaflet W2. The corresponding spring rings B8 must be made of A4 acc. to DIN 7980.
- Grease the thread of the mounting boss as well as the thread and the support of the terminal screws with a suitable lubricant. The lubricant must be suitable for material combination 316L/316L and for a temperature range of -50 ... +250°C (-58 ... +482°F) e.g. Varybond type NSS-16/7. The threads are already supplied with a lubricant.

4.2 Mounting procedure

The lock fitting is already premounted.

The numbers in brackets refer to the following illustration.

- 1 Loosen the screw (6) and remove the locking bracket (4)
- 2 Screw mounting boss (7) with a resistant seal ring into the thread of the vessel and tighten the mounting boss (7) on the hexagon (SW 75)
- 3 Clean the connection tube of the sensor and the surfaces of the clamp (1) as well as the pressure screw (11) carefully and remove grease, oil and dirt. Insert the sensor into the lock fitting. Slide the tube into the requested position and hold it
- 4 Make sure that the sensor is in the correct position (height). The height adjustment of the sensor determines also the switching point
- 5 Tighten the pressure screw (11) with a torque 240 ± 10 Nm (177 ± 7 lbf ft)
- 6 Continue to turn the pressure screw (11) clockwise until the hexagon surfaces of the pressure screw (11) and the mounting boss (7) correspond (max. 1/6 turn)

- 7 Tighten the terminal screws (3) alternately. Make sure that the gap between clamp and pressure screw is in parallel. Tighten the terminal screws up to a torque of 10 ± 1 Nm (7 ± 0.7 lbf ft).

Hence the clamp (1) is pressed against the tube and fixes the tube of the sensor in this position

- 8 Fasten the locking angle (4) with the hold screw (6) and the spring ring (5) laterally on the pressure screw (11)

Hence the pressure screw and the terminal screws are protected against unintentional loosening

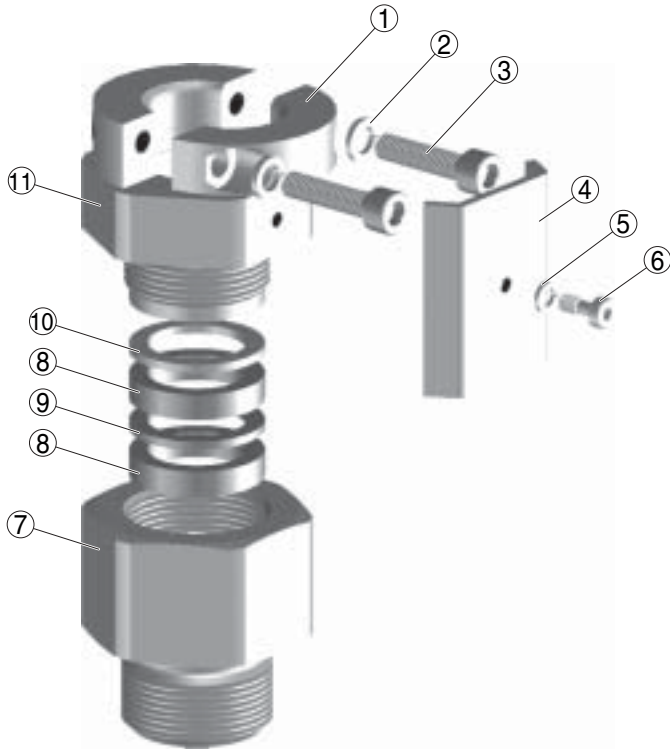

Fig. 1: Lock fitting ARV 67 - up to 16 bar (232 psi)

- 1 Clamp
- 2 Spring ring B8
- 3 Terminal screw M8 x 30
- 4 Locking angle
- 5 Spring ring B4
- 6 Holding screw M4 x 10
- 7 Mounting boss
- 8 Gasket ring
- 9 Graphite gasket ring
- 10 Pressure ring
- 11 Pressure screw

5 Maintenance and fault rectification

5.1 Maintenance

When used as directed in normal operation, lock fitting ARV 67 is completely maintenance-free.

5.2 Exchange seals

If the lock fitting is untight, you have to exchange the graphite gasket rings. If you want to shift the sensor to change the switching point, you also have to replace the graphite gasket rings.

The numbers in brackets refer to the illustration under "Mounting".



Danger:

Before dismantling, make sure that the vessel is unpressurised

- 1 Loosen the screw (6) and remove the locking bracket (4)
- 2 Loosen pressure screw (11)
- 3 Hold the tube of the sensor and loosen the terminal screws (3)
- 4 Pull the sensor out of the lock fitting
- 5 Unscrew the pressure screw (11) out of the mounting boss (7)
- 6 Screw the mounting boss (7) with a new resistant seal ring into the thread of the vessel and tighten the mounting boss (7) on the hexagon (SW 75)
- 7 Unpack the new gasket and graphite gasket rings. The graphite gasket ring (9) is thin; the gasket rings (8) are a little thicker and have a layer configuration.

Make sure that the rings are not damaged. If you are not sure, use new rings.
- 8 First of all place one of the new gasket rings (8) into the mounting boss (7). Then place the graphite gasket ring (9) on top. This is followed by the second gasket ring (8)
- 9 Place the pressure ring (10) of metal to the gasket rings

- 10 Screw the pressure screw (11) with a view turns from top into the mounting boss (7)
- 11 Clean the connection tube of the sensor and the surfaces of the clamp (1) as well as the pressure screw (11) carefully and remove grease, oil and dirt. Insert the sensor into the lock fitting. Slide the tube into the requested position and hold it
- 12 Make sure that the sensor is in the correct position (height). The height adjustment of the sensor determines also the switching point
- 13 Tighten the pressure screw (11) with a torque 240 ± 10 Nm (177 ± 7 lbf ft)
- 14 Continue to turn the pressure screw (11) clockwise until the hexagon surfaces of the pressure screw (11) and the mounting boss (7) correspond (max. 1/6 turn)
- 15 Tighten the terminal screws (3) alternately. Make sure that the gap between clamp and pressure screw is in parallel. Tighten the terminal screws up to a torque of 10 ± 1 Nm (7 ± 0.7 lbf ft).

Hence the clamp (1) is pressed against the tube and fixes the tube of the sensor in this position

- 16 Fasten the locking angle (4) with the hold screw (6) and the spring ring (5) laterally on the pressure screw (11)

Hence the pressure screw and the terminal screws are protected against unintentional loosening

5.3 Instrument repair

If a repair is necessary, please proceed as follows:

You can download a return form from our Internet homepage http://www.krohne-mar.com/fileadmin/media-lounge/PDF-Download/Specimen_e.pdf.

By doing this you help us carry out the repair quickly and without having to call back for needed information.

- Print and fill out one form per instrument
- Clean the instrument and pack it damage-proof
- Attach the completed form and possibly also a safety data sheet to the instrument.

6 Dismounting

6.1 Dismounting procedure

Note chapter "Mounting" and carry out the described steps in reverse order.



Warning:

If you want to remove the lock fitting for service or control purposes, make sure that the vessel is unpressurised.

If you proceed as follows, it is not necessary to readjust the switching point and the lock fittings must not be dismantled completely.

- 1 Switch off power supply of the sensor
- 2 Remove all connection cables
- 3 Loosen the mounting boss with a screwdriver
- 4 Remove the sensor together with the lock fitting

6.2 Disposal

The ARV 67 consists of materials which can be recycled by special recycling companies. Mark the instrument as scrap and dispose it according to the legal regulations.

Materials: see "*Technical data*"

If you cannot dispose of the instrument properly, please contact us about disposal methods or return.

7 Supplement

7.1 Technical data

General data

Material 316L corresponds to 1.4404 or 1.4435

Process fitting	G2A or 2 NPT
Tube diameter of the sensor	ø 43 mm acc. to DIN 2463/2462 D4-T3 (ø 1.7 in)
Materials	
– Lock fitting	316L or Hastelloy C22 (2.4602)
– Graphite packing rings	graphite
– Process seal	Klingsil C-4400 ¹⁾
Terminal screws	Hexagon screws DIN 912 M8 x 30 material A4-70 acc. to AD leaflet W2; corresponding spring rings B8 materials A4 acc. to DIN 7980
Holding screw	Hexagon screw DIN 7964 M4 x 10 material A4-70; corresponding spring ring B4 material A4 acc. to DIN 7980
Torque	
– Terminal screws	10 ±1 Nm (7 ±0.7 lbf ft)
– Pressure screw	240 ±10 Nm (177 ±7 lbf ft)

Process conditions

Operating pressure 16 bar (232 psi)	Take note of the nominal pressure of the sensor. The lower permissible operating pressure is valid.
Product temperature	-50 ... +150°C (-58 ... +302°F)

Approvals²⁾

In conjunction with a corresponding level sensor, ARV 67 has the following approvals.

ATEX ia	ATEX II 1G, 1/2G, 2G EEx ia IIC T6
ATEX d	ATEX II 1/2G, 2G EEx d IIC T6
ATEX	ATEX II 1/2D IP66 T

¹⁾ not with thread NPT

²⁾ Take note of the corresponding certificates of the sensor

7.2 Dimensions

Lock fitting ARV 67 for OPTISWITCH 3300 C

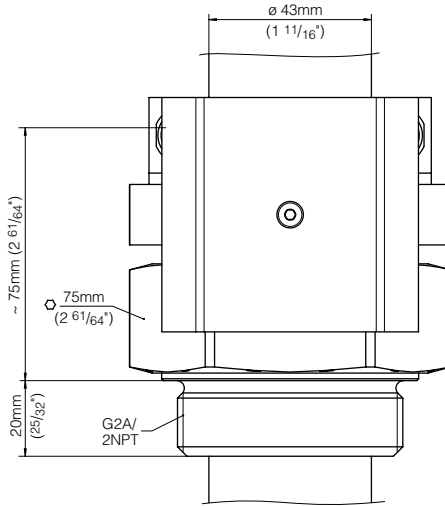

Fig. 2: Lock fitting ARV 67 up to 16 bar (232 psi) for OPTISWITCH 3300 C

Subject to change without notice