

Signal converters for electromagnetic flowmeters

Installation and
operating
instructions

IFC 010 K
IFC 010 F

How to use these Instructions

The flowmeters are supplied ready for operation.

The primary head must be installed in the pipeline as described in the installation instructions inside the packing of the primary head.

- Installation location and connection to power (Section 1)
- Electrical connection of outputs and inputs (Section 2)
- Factory settings and start-up (Section 3)
- **Operator control of the signal converter** is described in Sections 4 and 5.

Pages 1/1-1/6

Pages 2/1-2/6

Pages 3/1-3/2

Power the flowmeter. THAT'S ALL. The system is operative.

16-page pull-out condensed instructions

are located in the centrefold of these Installation and Operation Instructions.

Contents:

Installation (Sect. 1), electrical connection (Sect. 1 + 2), start-up (Sect. 3) and operator control of the signal converter (Sect. 4)



Applicable to Software Versions

- IFC 010 – / D
Display version
No. **806325.07**
and
No. **317551.02**
and higher
- IFC 010 – / B
Basic version
operator-controllable
with HHT 010
No. **806323.06**
and higher

Contents

Versions IFC 010 signal converter	0/3
Items included with supply	0/3
Software history	0/3
System description	0/4
Product liability and warranty	0/4
CE / EMC / Standards / Approvals	0/4

Part A System installation and start-up **1/1-3/2**

1	<u>Electrical connection: power supply</u>	<u>1/1-1/6</u>
1.1	Important installation notes – PLEASE NOTE !	1/1
1.1.1	Location	1/1
1.1.2	Only for separate systems/signal converters (F versions)	1/1
1.1.3	Cable entries	1/1
1.2	Connection to power	1/2
1.3	Electrical connection of separate primary head (F Version)	1/3-1/6
1.3.1	General information on signal cable A and field current cable C	1/3
1.3.2	Grounding of primary head	1/3
1.3.3	Stripping (preparation) of signal converter	1/4
1.3.4	Cable length (max. distance between signal converter and primary head)	1/5
1.3.5	Connection diagrams I and II (power supply, converter and primary head)	1/6
2	<u>Electrical connection of outputs</u>	<u>2/1-2/2</u>
2.1	Current output I	2/1
2.2	Pulse output P and status output S	2/1
2.3	Connection diagrams for outputs and inputs	2/2
3.	<u>Start-up</u>	<u>3/1-3/2</u>
3.1	Power-on and measurement	3/1
3.2	Factory settings	3/2

Part B IFC 010_ /D Signal converter **4/1-5/14**

4	<u>Operation of the signal converter</u>	<u>4/1-4/10</u>
4.1	Krohne operator control concept	4/1
4.2	Operating and check elements	4/2
4.3	Function of keys	4/3-4/4
4.4	Table of settable functions	4/5-4/9
4.5	Error messages in measuring mode	4/9
4.6	Reset totalizer and cancel error messages, RESET/QUIT menu	4/10
4.7	Examples of setting the signal converter	4/10
5	<u>Description of functions</u>	<u>5/1-5/12</u>
5.1	Full-scale range $Q_{100\%}$	5/1
5.2	Time constant	5/1
5.3	Low-flow cutoff	5/2
5.4	Display	5/2-5/3
5.5	Internal electronic totalizer	5/3
5.6	Current output I	5/4
5.7	Pulse output P	5/5-5/6
5.8	Status output S	5/7
5.9	Language	5/8
5.10	Entry code	5/8
5.11	Primary head	5/9
5.12	User-defined unit	5/10
5.13	F/R mode, forward/reverse flow measurement	5/11
5.14	Characteristic of outputs	5/11
5.15	Applications	5/12
5.16	Setting data	5/12

Part C	Special applications, functional checks, service, and order numbers	6/1-9/1
6	Special applications	6/1-6/2
6.1	HHT 010 hand held terminal and RS 232 adapter incl. CONFIG software (options)	6/1
6.2	Stable signal outputs when measuring tube empty	6/2
7	Functional checks	7/1-7/11
7.1	Zero check with IFC 010 _ /D, signal converter, Fct. 3.03	7/1
7.2	Test of measuring range Q, Fct. 2.01	7/1
7.3	Hardware information and error status, Fct. 2.02	7/2
7.4	Faults and symptoms during start-up and process flow measurement	7/3-7/6
7.5	Test of primary head	7/7
7.6	Test of signal converter	7/8
7.7	Test of signal converter using GS 8A simulator (option)	7/9-7/11
8	Service	8/1-8/6
8.1	Cleaning the signal converter housing	8/1
8.2	Replacement of power fuse(s)	8/1
8.3	Changeover of operating voltage on AC Versions 1, 2 and 3 (not DC Version)	8/2
8.4	Replacement of electronic unit of signal converter	8/2
8.5	Illustrations to Sect. 8.2 to 8.7	8/3
8.6	Turning the display PCB	8/4
8.7	Retrofitting the display unit	8/4
8.8	IFC 080 and SC 80 AS Replacement of electronic unit by IFC 010	8/4
8.9	Illustrations of the PCBs	8/6
9	Order numbers	9/1
Part D	Technical data, measuring principle and block diagram	10/1-12/1
10	Technical data	10/1-10/5
10.1	Full-scale range $Q_{100\%}$	10/1
10.2	Error limits at reference conditions	10/2
10.3	IFC 010 Signal converter	10/3-10/4
10.4	IFC 010 F and ZD dimensions and weights	10/4
10.5	Instrument name plates	10/5
11	Measuring principle and function of the system	11/1
12	Block diagram - signal converter	12/1
Part E	Index	E1-E2
Printed form to accompany flowmeters returned to Krohne		E3

Versions IFC 010 signal converter

IFC 010_ / B Basic version (standard)
without local display and control elements.
 All operating data factory-set to your order specifications.
 Optionally available for operator control:
 - RS 232 adapter, incl. software for DOS-PC **or**
 - HHT hand-held terminal

IFC 010_ / D Display version (option)
with local display and control elements.
 All operating data factory-set to your order specifications.

IFC 010 K / _ Compact flowmeter
 signal converter mounted direct on primary head.

IFC 010 F / _ Signal converter in field housing,
 electrical connection to primary head
 via field power and signal cables.

Items included with supply

- Signal converter in the version as ordered, see above.
- These installation and operating instructions for the signal converter, including 16-page pull-out condensed instructions for installation, electrical connection, start-up and operator control of the signal converter.
- 2 plug connectors for connection of power supply and outputs/inputs
- for separate system version only, F Version:
 signal cable in the version and length as ordered (standard: signal cable A, length 10 m / 30 ft)

Software history

Display & control unit		Hand-held HHT 010		CONFIG user software	
IFC 010_ / D		IFC 010_ / B**		IMoCom	RS 485
Software	Status	Software	Status	Software	Software
806325.07*	current	806328.06	current	V 2.00 and higher	V 3.15 and higher
≥ 317551.02*	replaces 806325.07	806328.06	current		
813269.00***	current	Czech user interface ***			
813340.00***	current	Swedish user interface ***			

* At least the same setting ranges and functional scope as preceding versions.
 Also, customer- and application-specific add-on equipment possible, which has to be installed and activated by the factory. Documented by enclosures to these Installation and Operating Instructions.

** **Please note:** Connect HHT 010 only to devices **without** display and operator control software.

*** Does not contain the functional scope of the currently valid standard version; this has been taken into account in the documentation of the respective national language.

System description

Electromagnetic flowmeters with the IFC 010 signal converter are precision instruments designed for linear flow measurement of liquid products.

The process liquids must be electrically conductive: $\geq 5 \mu\text{S/cm}$
(for cold demineralized water $\geq 20 \mu\text{S/cm}$).

The full-scale range $Q_{100\%}$ can be set as a function of the meter size:
DN 2.5 - 1000 / 1/10" - 40" $Q_{100\%} = 0.01 - 34\,000 \text{ m}^3/\text{hr} = 0.03 - 151\,000 \text{ US Gal/min}$
This is equivalent to a flow velocity of 0.3 - 12 m/s or 1 - 40 ft/s.

Product liability and warranty

The electromagnetic flowmeters with the IFC 010 signal converter are designed solely for measuring the volumetric flowrate of electrically conductive, liquid process products.

These flowmeters are not certified for use in hazardous areas. Other flowmeter series are available for such applications.

Responsibility as to suitability and intended use of these electromagnetic flowmeters rests solely with the operator.

Improper installation and operation of the flowmeters (systems) may lead to loss of warranty.

In addition, the "General conditions of sale" forming the basis of the purchase contract are applicable.

If flowmeters need to be returned to Krohne, please note the information given on the last-but-one page of these Instructions. Krohne regrets that it cannot repair or check your flowmeter(s) unless accompanied by the completed form sheet.

CE / EMC / Standards / Approvals

- Electromagnetic flowmeters with the IFC 010 signal converter meet the protection requirements of **Directive 89/336/EEC** in conjunction with **EN 50081-1** (1992) and **EN 50082-2** (1995), as well as **Directives 73/23/EEC** and **93/68/EEC** in conjunction with **EN 61010-1**, and bear the **CE marking**.



Part A System installation and start-up

1 Electrical connection: power supply

1.1 Important installation notes

PLEASE NOTE !

1.1.1 Location

- **Electrical connection in accordance with VDE 0100** "Regulations governing heavy-current installations with line voltages up to 1000 V" or **equivalent national regulations**.
- Do not cross or loop **cables inside the terminal compartment**.
- Use **separate cable entries** (see below) for power supply, field current cables, signal lines, outputs and inputs.
- Protect flowmeters or switchgear cabinets with built-in devices from direct **sunlight**. Fit a sunshade if necessary.
- When installed in switchgear cabinets, signal converters must be adequately cooled, e.g. use fans or heat exchangers.
- Do not expose signal converters to intense **vibration**.

1.1.2 Only for separate systems/signal converters (F versions)

- Keep **distance between primary head and signal converter** as short as possible. Refer to Sect. 1.3.4 for maximum permissible length of signal and field current cables.
- Use the supplied **Krohne signal cable A** (Type DS), standard length 10 m (33 ft).
- Always **calibrate** primary head and signal converter **together**. Therefore, when installing, ensure **primary constant GKL is identical**; refer to instrument nameplate for the primary head. Refer also to Sections 4.
- **Dimensions of signal converter**; refer to Section 10.4.

1.1.3 Cable entries

Number of cable entries: **2** for the compact flowmeters
4 for the IFC 010 F signal converter

NOTE: Ensure gaskets are fitted correctly and maintain the following max. torques!

- 1 Max. torques for PG 13.5,
1/2" NPT or 1/2" PF adapters: **4 Nm / 2.8 ft × lbf**
- 2 Max. torques for PG 13.5 only: **3 Nm / 2.1 ft × lbf**
- 3 Gasket

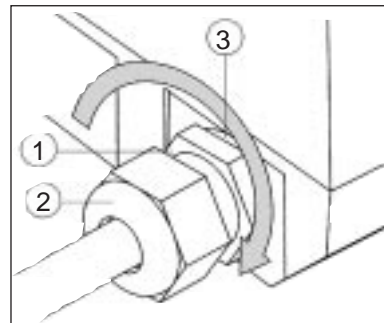

A) PG 13.5 cable entries

These cable entries may only be used for flexible electrical cables if the relevant electrical regulations so allow, e.g. National Electric Code (NEC). Do not fix rigid metal conduits (IMC) or flexible plastic conduits to the PG 13.5 cable entries, refer to "Point B, C" below (1/2" NPT or PF adapters).

B) 1/2" NPT adapters

C) 1/2" PF adapters

For most North American systems the regulations require that electrical conductors be laid in conduits, particularly where power voltages > 100 V AC are concerned.

In such cases, use the 1/2" NPT or 1/2" PF adapters to which flexible plastic conduits can be screwed. **Do not use rigid metal conduits (IMC)!**

Lay conduits such that no moisture can penetrate into the converter housing.

Should there be risk of any condensation water forming, fill the cross-section of the conduit around the cables at these adapters with a suitable sealing compound.

PLEASE NOTE !

- Rated values: The flowmeter housings protecting the electronic equipment from dust and moisture must always be kept closed. The selected creepage distances and clearances have been dimensioned in conformity with VDE 0110 and IEC 664 for contamination category 2. Supply circuits and output circuits are designed to meet the standards of overvoltage classes III and II, respectively.
- Safety isolation: the flowmeters (signal converters) must be provided with an isolating facility.

1. AC Version

230/240 V AC (200 - 260 V AC)
switch-selectable to
115/120 V AC (100 - 130 V AC)

2. AC Version

200 V AC (170 - 220 V AC)
switch-selectable to
100 V AC (85 - 110 V AC)

- **Note information on instrument nameplate:** supply voltage and frequency
- The **PE protective ground conductor** for the power supply **must be connected** to the separate U-clamp terminal in the terminal compartment of the signal converter. For exceptions (compact systems), refer to installation instructions for the primary head.
- **Connection diagrams I and II** for electrical connection between primary head and signal converter: refer to Section 1.3.5.

3. AC Version

48 V AC (41 - 53 V AC)
switch-selectable to
24 V AC (20 - 26 V AC)

DC Version

24 V DC (11-32 V DC)

- **Note information on instrument nameplate:** supply voltage and frequency.
- For measurement reasons, connect an **FE functional ground conductor** to the separate U-clamp terminal in the terminal compartment of the signal converter.
- If connected to a functional extra-low voltage source (24 V AC / DC, 48 V AC), provide for **protective separation (PELV)** in conformity with VDE 0100 / VDE 0106 or IEC 364 / IEC 536, or equivalent national regulations.
- **Connection diagrams I and II** for power supply and electrical connection between primary head and signal converter: refer to Section 1.3.5.

Connection to power

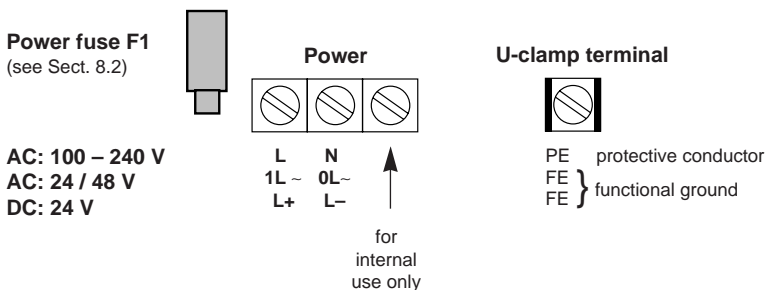

Warning: Instrument must be properly grounded to avoid personnel shock hazard.

1.3 Electrical connection of separate primary head (F Versions)

1.3.1 General information on signal cable A and field current cable C

Use of the Krohne signal cable A with foil screen and magnetic shield will ensure proper operation of the equipment.

- Signal cable to be solidly laid.
- Connect shields via stranded drain wires.
- Underwater and underground installation possible.
- Insulating material is flame-retardant to IEC IEC 332.1 / VDE 0742.
- Signal cables are low in halogen, unplasticized, and stay flexible at low temperatures.

Signal cable A (Type DS), with double shielding

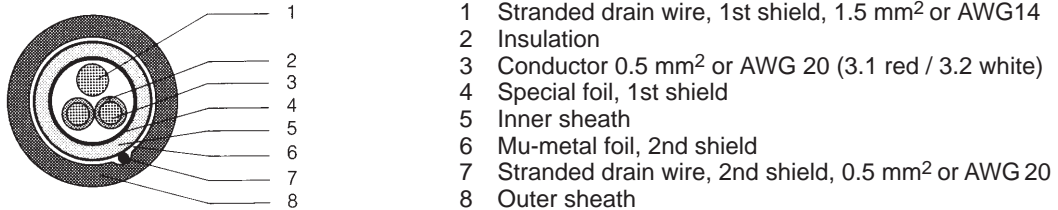

Field current cable C with single shielding

Cross-section is dependent on required length of cable, see Table in Sect. 1.3.4.

1.3.2 Grounding of primary head

All flowmeters must be properly grounded.

- The grounding conductor should not transmit any interference voltages.
- Do not ground any other electrical device together with this conductor.
- The primary head is connected to ground by means of an **FE functional ground conductor**.
- Special information on grounding various primary heads is contained in the separate **installation instructions for primary heads**.
- These instructions also contain detailed descriptions on how to use grounding rings and how to install primary heads in metal or plastic pipes or internally coated pipelines.

Stripping (preparation) of signal cable A 1.3.3

Please note the different lengths given in the table for signal converter and primary head.

Length	Converter		Primary head	
	mm	(inch)	mm	(inch)
a	55	(2.17)	90	(3.60)
b	10	(0.39)	8	(0.30)
c	15	(0.59)	25	(1.00)
d	8	(0.30)	8	(0.30)

Customer-supplied materials

W	Insulation tubing (PVC), \varnothing 2.0 - 2.5 mm (dia. 1")
X	Heat-shrinkable tubing or cable sleeve
Y	Wire end sleeve to DIN 41 228: E 1.5-8
Z	Wire end sleeve to DIN 41 228: E 0.5-8

Preparation for connection to primary head

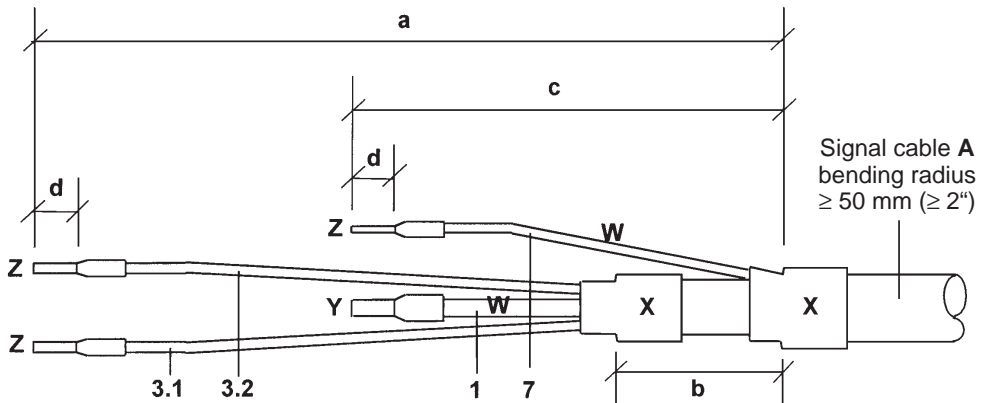

Preparation for connection to IFC 010 F signal converter

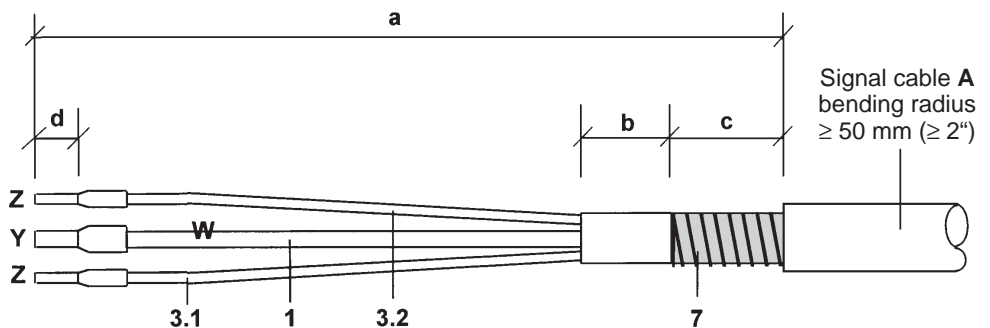

External shielding of signal cable A (Type DS)

Wrap stranded drain wire (7) around the mu-metal foil (6) and clamp under the shield terminal in the signal converter terminal box (see also diagram in Sect. 1.3.5).

Cable routing in signal converter housing

see illustration in Sect. 10.4.

1.3.4 Cable lengths (max. distance between signal converter and primary head)

Abbreviations and explanatory notes

used in the following tables, diagrams and connection diagrams

A Signal cable A (type DS), with double shielding, see diagram for max. length

C Field current cable C, with single shielding, type and length see Table

D High-temperature silicone cable, $3 \times 1.5 \text{ mm}^2$ (14 AWG) Cu, with single shielding, max. length 5 m (16 ft)

E High-temperature silicone cable, $2 \times 1.5 \text{ mm}^2$ (14 AWG) Cu, max. length 5 m (16 ft)

L Cable length

κ Electrical conductivity of the process liquid

ZD Intermediate connection box required in connection with cables D and E for primary heads ALTOFLUX IFS 4000 F, PROFIFLUX IFS 5000 F and VARIFLUX IFS 6000 F in cases where process temperatures exceed $150 \text{ }^\circ\text{C}$ ($302 \text{ }^\circ\text{F}$)

Recommended length of signal cable

for magnetic field frequency $\leq 1/6 \times$ power frequency

Primary head	Meter size		Signal cable
	DN mm	inch	
ECOFLUX IFS 1000 F	10 - 15	$3/8 - 1/2$	A4
	25 - 150	1 - 6	A3
AQUAFLUX F	10 - 1000	$3/8 - 40$	A1
ALTOFLUX IFS 4000 F	10 - 150	$3/8 - 6$	A2
	200 - 1000	8 - 40	A1
PROFIFLUX IFS 5000 F	2.5 - 15	$1/10 - 1/2$	A4
	25 - 100	1 - 4	A2
VARIFLUX IFS 6000 F	10 - 15	$1/8 - 1/2$	A4
	25 - 80	1 - 3	A2

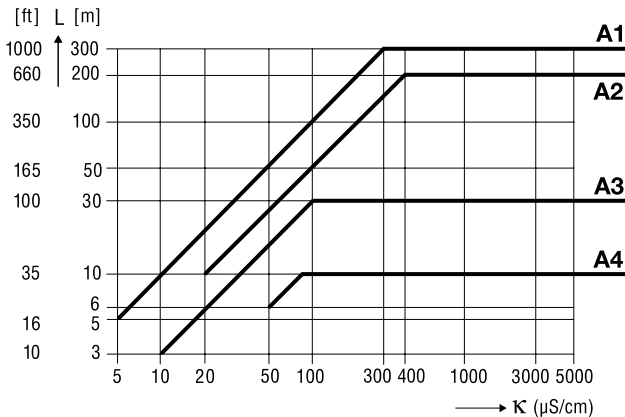

Field current cable C: max. length and min. cross-section

Length	Type of cable, single shielding
0 - 150 m 5 - 500 ft	$2 \times 0.75 \text{ mm}^2 \text{ Cu}$ / $2 \times 18 \text{ AWG}$
150 - 300 m 500 - 1000 ft	$2 \times 1.50 \text{ mm}^2 \text{ Cu}$ / $2 \times 14 \text{ AWG}$

Warning: Instrument must be properly grounded to avoid personnel shock hazard.

Important information PLEASE NOTE !

- The figures in brackets indicate the stranded drain wires for the shields, see cross-sectional drawing of signal cable in Section 1.3.1.
- **Electrical connection to VDE 0100** "Regulations governing heavy-current installations with line voltages up to 1000 V" or equivalent national regulations.
- **Power supply 24 V AC / DC:** functional extra-low voltage with protective separation in conformity with VDE 0100, Part 410 or equivalent national regulations.
- **PE = protective conductor** **FE = functional ground conductor**

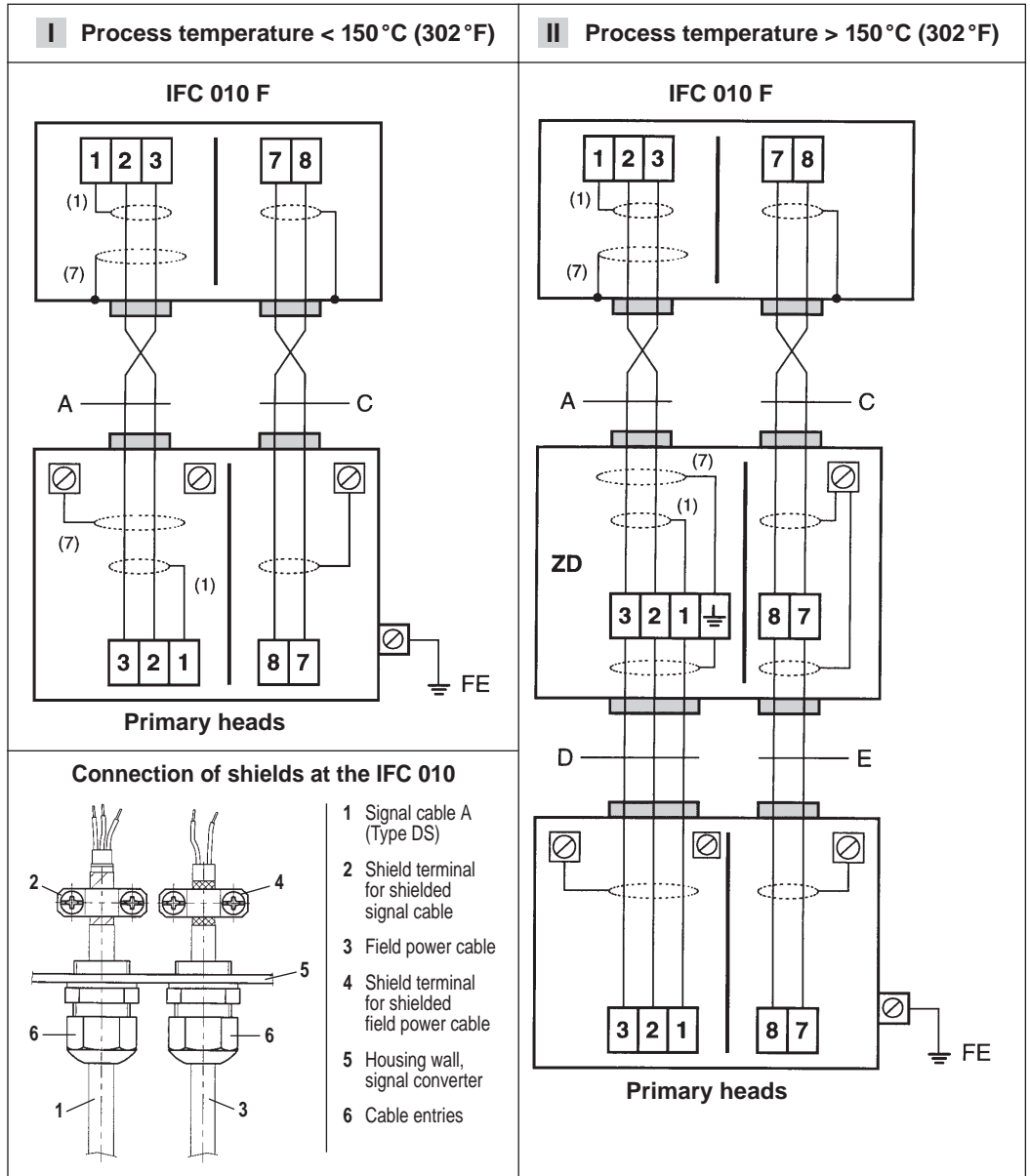

2 Electrical connection of outputs

2.1 Current output I

- The current output is galvanically isolated from all input and output circuits.
- Factory-set data and functions can be noted down in Sect. 5.16.
Please also refer to Sect. 3.2 “Factory settings”.
- Typical current output

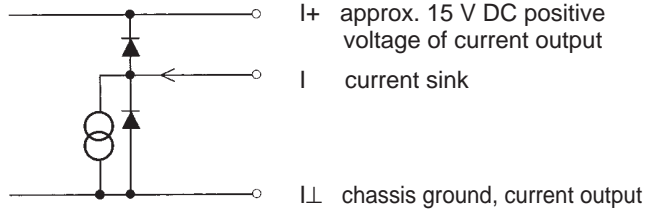

- All operating data and functions can be set.
- **Display** version: IFC 010 **D**, see Sect. 4 and 5.6, Fct. 1.05 for operator control
Basic version: IFC 010 **B**, see Sect. 6.1 for operator control
- The current output can also be used as an internal voltage source for the outputs.
 $U_{\text{int}} = 15 \text{ V DC}$ $I = 23 \text{ mA}$ when operated **without** receiver instruments at the current output
 $I = 3 \text{ mA}$ when operated **with** receiver instruments at the current output
- **Connection diagrams**, see Sect. 2.3: diagrams ① ② ④ ⑥

2.2 Pulse output P and status output S

- The pulse and status outputs are galvanically isolated from the current output and all input circuits.
- Factory-set data and functions can be noted down in Sect. 5.16.
Please also refer to Sect. 3.2 “Factory settings”.
- Typical pulse and status outputs B1

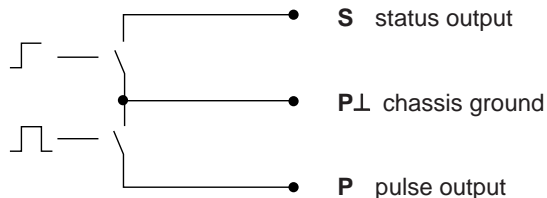

- All operating data and functions can be set:
Display version: IFC 010 **D**, see Sect. 4 and 5.7, Fct. 1.06 for operator control
Basic version: IFC 010 **B**, see Sect. 6.1 for operator control
- The pulse and status outputs can be operated in the active or passive mode.
Active mode: The current output is the internal voltage source, connection of electronic totalizers (EC)
Passive mode: External DC or AC voltage source required, connection of electronic (EC) or electromechanical (EMC) totalizers
- Digital pulse division, interpulse period is non-uniform. Therefore, if frequency meters or cycle counters are connected, allow for minimum counting interval:

$$\text{gate time, counter} \leq \frac{1000}{P_{100\%} [\text{Hz}]}$$

- **Connection diagrams** see Sect. 2.3: diagrams - pulse output ③ ④
diagrams - status output ⑤ ⑥

Connection diagrams for outputs 2.3



Milliammeter



Totalizer
 – electronic (EC)
 – electromechanical (EMC)



DC voltage,
 external power source (U_{ext}),
 note connection polarity



External voltage source (U_{ext}),
 DC or AC voltage,
 connection polarity arbitrary

1 Stromausgang I_{active}

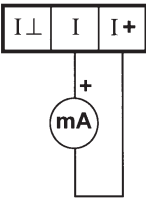

$I = 0/4 - 20 \text{ mA}$
 $R_i \leq 500 \Omega$

2 Stromausgang $I_{passive}$

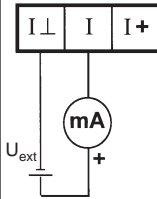

$I = 0/4 - 20 \text{ mA}$
 $U_{ext} \quad 15...20 \text{ V DC} \quad | \quad 20...32 \text{ VDC}$
 $R_i \quad 0...500 \Omega \quad | \quad 250...750 \Omega$

Active mode

The current output supplies the power for operation of the outputs.

Passive mode

External power source required for operation of the outputs.

3 Pulse output $P_{passive}$ for electronic (EC) or electromechanical (EMC) totalizers

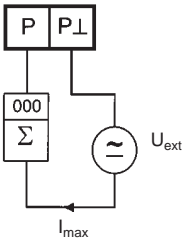

$U_{ext} \leq 32 \text{ V DC} / \leq 24 \text{ V AC}$
 $I_{max} \leq 150 \text{ mA}$
 (incl. status output)

4 Pulse output P_{active} (and current output I_{active}) for electronic (EC) totalizers with and without current output I

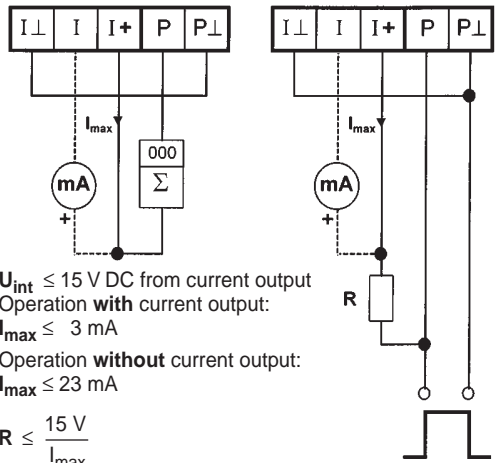

$U_{int} \leq 15 \text{ V DC}$ from current output
 Operation **with** current output:
 $I_{max} \leq 3 \text{ mA}$
 Operation **without** current output:
 $I_{max} \leq 23 \text{ mA}$
 $R \leq \frac{15 \text{ V}}{I_{max}}$

5 Status output $S_{passive}$

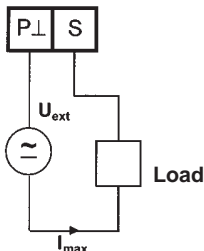

$U_{ext} \leq 32 \text{ V DC} / \leq 24 \text{ V AC}$
 $I_{max} \leq 150 \text{ mA}$
 (incl. pulse output)

6 Status output S_{active} with and without current output I

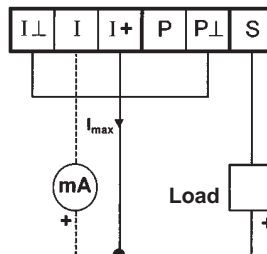

$U_{int} \leq 15 \text{ V DC}$
 from current output
 $I_{max} \leq 3 \text{ mA}$
 Operation **with**
 current output
 $I_{max} \leq 23 \text{ mA}$
 Operation **without**
 current output

3 Start-up

3.1 Power-on and measurement



- Before powering the system, please check that it has been correctly installed according to Sect. 1 and 2.
- The flowmeter is delivered ready for operational use. All operating data have been factory set in accordance with your specifications.
Please refer to Sect. 3.2 “factory settings”.
- Power the unit, and the flowmeter will immediately start process flow measurement.



Basic version, signal converter IFC 010__ / B

- A light emitting diode (LED) under the cover of the electronic section shows the measurement status.

LED flashing . . .

  **green:** measurement correct, everything all right.

  **green/red:** momentary overdriving of outputs and/or A/D converter.

  **red:** fatal error, parameter error or hardware fault, please consult factory.

- Refer to Sect. 6.1 for operator control of the “basic version”.

Display version, signal converter IFC 010__ / D

- When powered, the display shows in succession: START UP and READY.
This is followed by display of the current flow rate and/or the current totalizer count on either a continuous or alternating basis, depending on the setting under Fct. 1.04.
- Refer to Sect. 4 and 5 for operator control of the “display version”.

All operating data are factory set according to your order specifications.

If you have not made any particular specifications at the time of ordering, the instruments will be delivered with the standard parameters and functions listed in the Table below.

To facilitate easy and rapid initial start-up, current output and pulse output are set to process flow measurement in “2 flow directions”, so that the current flowrate is displayed and the volumetric flow counted independent of the flow direction. On instruments equipped with a display, measured values may possibly be shown with a “-” sign.

This factory setting for the current and pulse outputs may possibly lead to measuring errors, particularly in the case of volume flow counting:

for example, if pumps are switched off and a “backflow” occurs which is not within the range of the low-flow cutoff (SMU), or if separate displays and counts are required for both flow directions.

To avoid faulty measurements, therefore, it may be necessary to change the factory setting of some or all of the following functions:

- low-flow cutoff SMU, Fct. 1.03, Sect. 5.3
- current output I, Fct. 1.05, Sect. 5.6
- pulse output P, Fct. 1.06, Sect. 5.7
- display (option), Fct. 1.04, Sect. 5.4

Instrument operation:

Display versions: IFC 010 _ / **D**, operation: refer to **Sect. 4 and 5**.

Basic versions: IFC 010 _ / **B**, operation: refer to **Sect. 6.1**.

Standard factory settings

Function		Setting
1.01	Full-scale range $Q_{100\%}$	see nameplate
1.02	Time constant	3 s, for I, S and display
1.03	Low-flow cutoff SMU	ON: 1 % OFF: 2 %
1.04	Display (option) flow rate totalizer(s)	m^3/hr or US Gal/min m^3 or US Gal
1.05	Current output I function range error message	2 directions 4 - 20 mA 22 mA
1.06	Pulse output P function pulse value pulse width	2 directions 1 pulse/s 50 ms
1.07	Status output P	flow direction

Function		Setting
3.01	Language for display only	English
3.02	Flowmeter diameter flow direction (see arrow on primary head)	see nameplate } + direction
3.04	Entry code	no
3.05	User unit	Liter/hr or USMGal/day

Teil B IFC 010 _ / D Signal converter

4 Operation of the signal converter

4.1 Krohne operator control concept

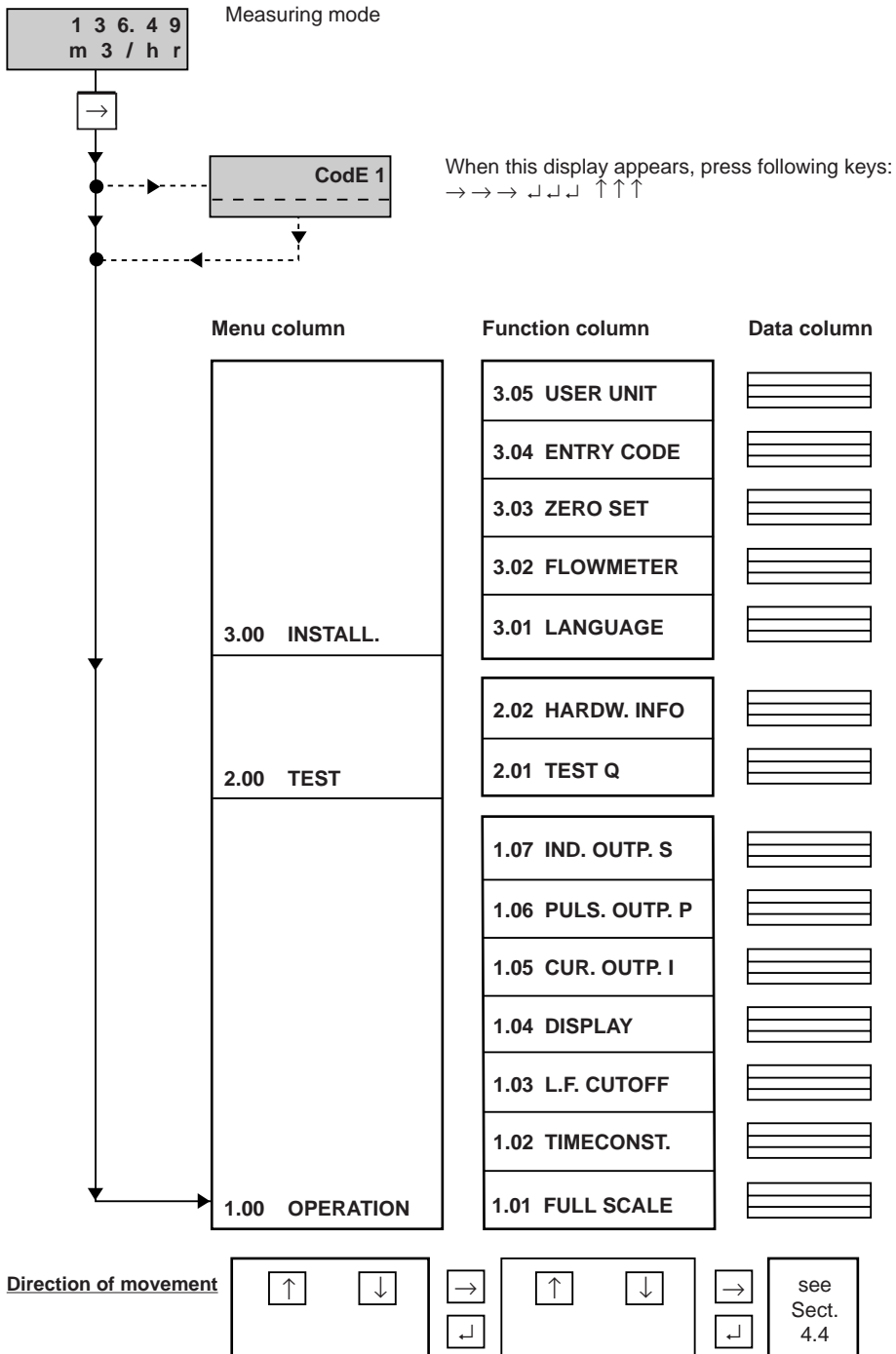

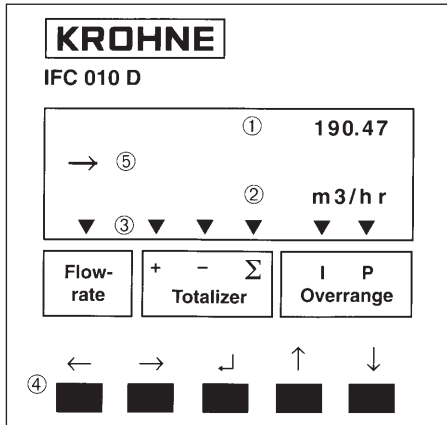

The controls are accessible after unscrewing the 4 screws and removing the housing cover.

- ① Display, 1st line
- ② Display, 2nd line
- ③ Display, 3rd line: arrows to identify display

Flowrate current flowrate

Totalizer + totalizer
 - totalizer
 Σ sum totalizer (+ and -)

Overrange I overranging, current output I
 P overranging, pulse output P

- ④ Keys for operator control of signal converter
- ⑤ Compass field, signals actuation of a key.

4.3 Function of keys

The **cursor** (flashing part of display) has a **grey** background in the following descriptions.

To start operator control

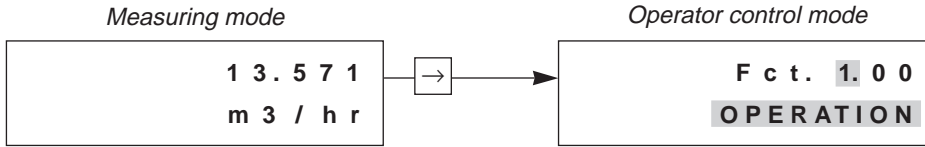

PLEASE NOTE: When "YES" is set under **Fct. 3.04 ENTRY CODE**, "CodE 1 - - - - -" appears in the display after pressing the → key.

The 9-keystroke Entry Code 1 must now be entered: →→→ ↵↵↵ ↑↑↑ (each keystroke acknowledged by "*").

To terminate operator control

Press key ↵ repeatedly until one of the following menus

Fct. 1.00 OPERATION, Fct. 2.00 TEST or Fct. 3.00 INSTALL. is displayed.

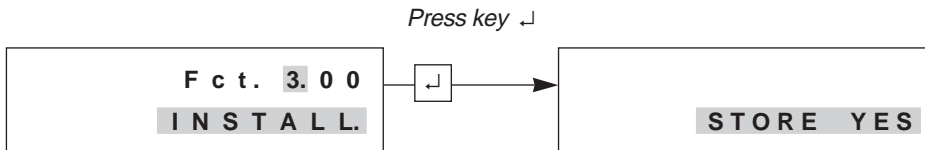

Store new parameters: acknowledge by pressing key ↵. Measuring mode continued with the new parameters.

New parameters not to be stored: press key ↑ to display „STORE.NO“. Measuring mode continued with the „old“ parameters after pressing key ↵.

To change numbers

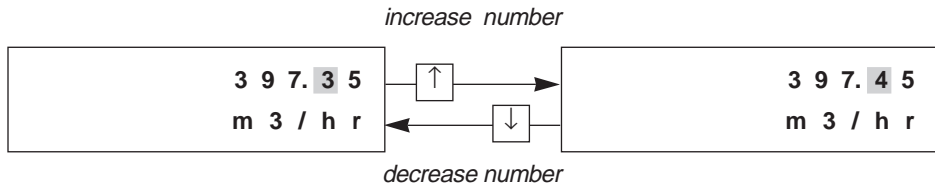

To shift cursor (flashing position)

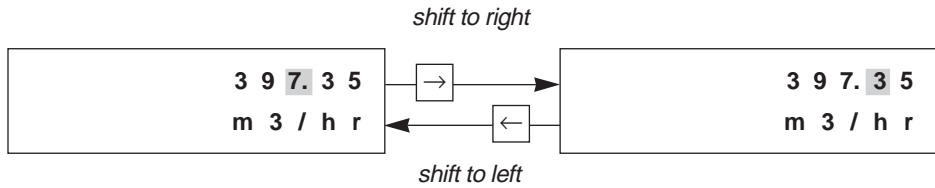

To alter texts (units)

For units, the numerical value is converted automatically.

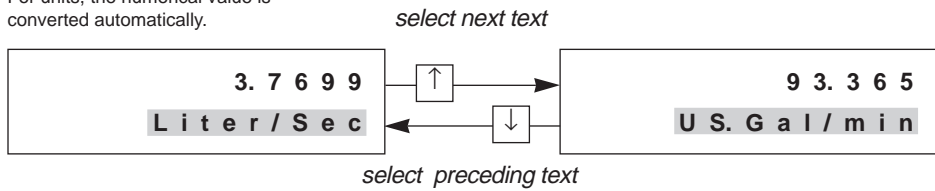

To transfer from text (unit) to number setting

Change to number setting

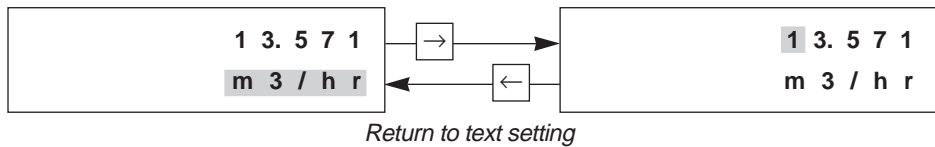

To transfer to subfunction

Subfunctions do not have a "Fct.No." and are identified by a "→".

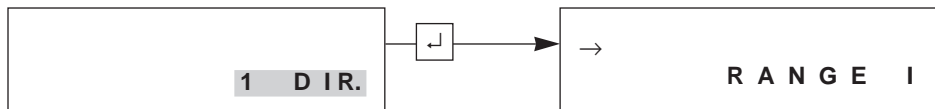

To revert to function display

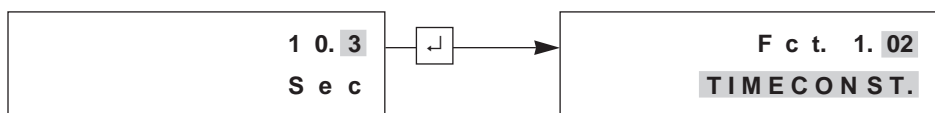

Fct.	Text	Description and settings
1.04	DISPLAY	Display functions
	→ DISP.FLOW	Select flow display <ul style="list-style-type: none"> • NO DISP. • user unit, factory set is "Liter/hr" or "US MGal/day" (see Fct. 3.05) • m3/hr • PERCENT • Liter/Sec • BARGRAPH (value and bargraph display in %) • US.Gal/min <i>Press ↵ key to transfer to subfunction "DISP. TOTAL."</i>
	→ DISP.TOTAL.	Select totalizer display <ul style="list-style-type: none"> • NO DISP. (totalizer switched on but not displayed) • OFF (totalizer switched off) • +TOTAL. • -TOTAL. • +/-TOTAL. • SUM (Σ) • ALL (display single counts or all)
		<ul style="list-style-type: none"> • m3 • Liter • US.Gal <ul style="list-style-type: none"> • user unit, factory set is "Liter" or "US MGal" (see Fct. 3.05). <i>Press → key to transfer to format setting.</i>
		Format setting <ul style="list-style-type: none"> • Auto (exponent notation) • # . ##### • ##### . ### • ## . ##### • ##### . ## • ### . ##### • ##### . # • #### . ##### • ##### <i>Press ↵ key to transfer to subfunction "DISP.MSG".</i>
→ DISP.MSG.	Additional messages required in measuring mode? <ul style="list-style-type: none"> • NO • YES (cyclic change with displays of measured values) <i>Press ↵ key to return to Fct. 1.04 DISPLAY.</i>	
1.05	CURRENT I	Current output I
	→ FUNCT. I	Select function for current output I <ul style="list-style-type: none"> • OFF (switched off) • 1 DIR. (1 flow direction) • 2 DIR. (forward/reverse flow, F/R flow measurement) <i>Press key ↵, transfer to subfunction "RANGE I"; if "2 DIR." selected, transfer to subfunction "REV.RANGE!"</i>
	→ RANGE I → I ERROR	Select measuring range <ul style="list-style-type: none"> • 0 - 20 mA • 4 - 20 mA (fixed ranges) <i>Press key ↵ to transfer to subfunction "I ERROR".</i> Select error value <ul style="list-style-type: none"> • 0 mA • 3.6 mA (only with range 4-20 mA) • 22 mA <i>Press key ↵ to revert to Fct. 1.05 CURRENT. I.</i>

Fct.	Text	Description and settings
1.06	PULS.OUTP. P	Pulse output P
	→ FUNCTION P	Select function for pulse output P <ul style="list-style-type: none"> • OFF (switched off) • 1 DIR. (1 flow direction) • 2 DIR. (forward/reverse flow, F/R measurement) <i>Press ↵ key to transfer to subfunction "SELECT P".</i>
	→ SELECT P	Select pulse type <ul style="list-style-type: none"> • 100 Hz • PULSE/VOL. (pulses per unit volume, flow rate) • 1000 Hz • PULSE/TIME (pulses per unit time for 100% flowrate) <i>Press ↵ key to transfer to subfunction "PULSWIDTH".</i> <i>When 100 Hz and 1000 Hz selected, return to Fct. 1.06 PULS.OUTP. P, pulse width 50% cyclic.</i>
	→ PULSWIDTH	Select pulse width <ul style="list-style-type: none"> • 50 mSec • 100 mSec • 200 mSec • 500 mSec • 1 Sec <i>Press ↵ key to transfer to subfunction "VALUE P".</i>
	→ VALUE P	Set pulse value per unit volume (appears only when "PULSE/VOL." has been set under "SELECT P"). <ul style="list-style-type: none"> • xxxx PulS/m3 • xxxx PulS/Liter • xxxx PulS/US.Gal • xxxx PulS/ user unit, factory set is "Liter" or "US MGal" (see Fct. 3.05). Setting range „xxxx“ is dependent on the pulse width and the full-scale range: $P_{min} = F_{min} / Q_{100\%}$ $P_{max} = F_{max} / Q_{100\%}$ <i>Press ↵ key to return to Fct. 1.06 "PULS.OUTP. P".</i>
→ VALUE P	Set pulse value per unit time (appears only when „PULSE/TIME“ has been set under „SELECT P“). <ul style="list-style-type: none"> • xxxx PulS/Sec (=Hz) • xxxx PulS/min • xxxx PulS/hr • xxxx PulS/user unit, factory set is "hr" or "day" (see Fct. 3.05) "xxxx" setting range is dependent on pulse width, see above. <i>Press ↵ key to return to Fct. 1.06 "PULS.OUTP. P".</i>	
1.07	IND. OUTP. S	Status output S <ul style="list-style-type: none"> • ALL ERROR • FATAL ERROR • OFF • ON • F/R INDIC. (F/R indication for forward/reverse measurement) • TRIP. POINT Setting range: 002 - 115 PERCENT • EMPTY PIPE (appears only when this option is installed) <i>(Press ↵ key to transfer to number setting.)</i> <i>Press ↵ key to return to Fct. 1.07 "IND.OUTP. S".</i>

Fct.	Text	Description and settings
2.00	TEST	Test menu
2.01	TEST Q	Test measuring range Q <i>Precautionary_query</i> <ul style="list-style-type: none"> • SURE NO <i>Press ↵ key to return to Fct. 2.01 "TEST Q".</i> • SURE YES <i>Press ↵ key, then use ↑ or ↓ key to select value: -110 / -100 / -50 / -10 / 0 / +10 / +50 / +100 / +110 PCT. of set full-scale range $Q_{100\%}$.</i> Displayed value present at outputs I and P. <i>Press ↵ key to return to Fct. 2.01 "TEST Q".</i>
	HARDW. INFO	Hardware information and error status Before consulting factory, please note down all 6 codes.
	→ MODUL ADC	X . X X X X X . X X Y Y Y Y Y Y Y Y Y Y <i>Press ↵ key to transfer to "MODUL IO".</i>
	→ MODUL IO	X . X X X X X . X X Y Y Y Y Y Y Y Y Y Y <i>Press ↵ key to transfer to "MODUL DISP.".</i>
	→ MODUL DISP.	X . X X X X X . X X Y Y Y Y Y Y Y Y Y Y <i>Press ↵ key to return to Fct. 2.02 "HARDW. INFO".</i>

Fct.	Text	Description and settings
3.00	INSTALL.	Installation menu
3.01	LANGUAGE	Select language for display texts <ul style="list-style-type: none"> • GB / USA (English) • D (German) • F (French) • others on request <i>Press ↵ key to return to Fct. 3.01 "LANGUAGE".</i>
3.02	FLOWMETER	Set data for primary head
	→ DIAMETER	Select size from meter size table <ul style="list-style-type: none"> • DN 10 - 1000 mm equivalent to 3/8 - 40 inch <i>Select with ↑ or ↓ key.</i> <i>Press ↵ key to transfer to subfunction "FULL SCALE".</i>
	→ FULL SCALE	Full-scale range for flow $Q_{100\%}$ To set, refer to Fct. 1.01 "FULL SCALE" above. <i>Press ↵ key to transfer to subfunction "GKL VALUE".</i>
	→ VALUE P	Pulse value (Fct. 1.06 "VALUE P") has been changed. With the "old" pulse values the output frequency (F) would have been exceeded or not reached. $P_{min} = F_{min} / Q_{100\%}$ $P_{max} = F_{max} / Q_{100\%}$ Check new values!
	→ GKL VALUE	Set primary constant GKL see primary head nameplate. Range: • 1.0000 - 9.9999 <i>Press ↵ key to transfer to subfunction "FIELD. FREQ.".</i>
	→ FIELD FREQ.	Magnetic field frequency Values: 1/6 or 1/18 of power frequency, see nameplate. <i>Press ↵ key to transfer to subfunction "FLOW DIR.";</i> DC units only: to transfer to subfunction "LINE FREQ.".
	→ LINE FREQ.	Normal line frequency in your country <u>Please note:</u> This function is only provided for units with DC power supply to suppress line-frequency interference. Values: <u>50 Hz</u> and <u>60 Hz</u> <i>Press ↵ key to transfer to subfunction "FLOW DIR.".</i>
	→ FLOW DIR.	Define flow direction (in F/R mode: forward flow). Set according to direction of arrow on primary head: <ul style="list-style-type: none"> • + DIR. • - DIR. <i>Select using ↑ or ↓ key.</i> <i>Press ↵ key to return to Fct. 3.02 "FLOWMETER".</i>
3.03	ZERO SET	Zero calibration <u>Note:</u> Carry out only at "0" flow and with completely filled measuring tube! <u>Precautionary query</u> <ul style="list-style-type: none"> • CALIB. NO <i>Press ↵ key to return to Fct. 3.03 "ZERO SET".</i> • CALIB. YES <i>Press ↵ key to start calibration.</i> Duration approx. 15–90 seconds, current flowrate displayed in the selected unit (see Fct. 1.04 "DISP. FLOW"). A "WARNING" sign appears when flowrate "> 0"; acknowledge by pressing ↵ key. • STORE NO (do not store new zero value) • STORE YES (store new zero value) <i>Press ↵ key to return to Fct. 3.03 "ZERO SET".</i>
3.04	ENTRY CODE	Entry code required to enter setting mode? <ul style="list-style-type: none"> • NO (= entry with → only) • YES (= entry with → and Code 1: → → → ↵ ↵ ↵ ↑ ↑ ↑) <i>Press ↵ to return to Fct. 3.04 "ENTRY CODE".</i>

Fct.	Text	Description and settings
3.05	USER UNIT	Set any required unit for flowrate and counting
	→ TEXT VOL.	Set text for required flowrate unit (max. 5 characters) Factory-set: "Liter" or "MGal". <u>Characters assignable to each place:</u> • A-Z, a-z, 0-9, or " - " (= blank character). <i>Press ↵ key to transfer to subfunction "FACT. VOL."</i>
	→ FACT. VOL.	Set conversion factor (F_M) for volume Factory set "1.00000" for "Liter" or "2.64172E-4" for "US MGal" (exponent notation, here: 1 × 10 ³ or 2.64172 × 10 ⁻⁴). <u>Factor F_M</u> = volume per 1m ³ . <u>Setting range</u> • 1.00000 E-9 to 9.99999 E+9 (= 10 ⁻⁹ to 10 ⁺⁹) <i>Press ↵ key to transfer to subfunction "TEXT TIME"</i> .
	→ TEXT TIME	Set text for required time unit (max. 3 characters) Factory-set: "hr" or "day": <u>Characters assignable to each place:</u> • A-Z, a-z, 0-9, or " - " (= blank character). <i>Press ↵ key to transfer to subfunction "FACT. TIME"</i>
	→ FACT. TIME	Set conversion factor (F_T) for time Factory-set: "3.60000 E+3" for "hour" or "8.64000 E+4" for "day" (exponent notation, here: 3.6 × 10 ³ or 8.64 × 10 ⁴). <u>Set factor F_T</u> in seconds. <u>Setting range</u> • 1.00000 E-9 to 9.99999 E+9 (= 10 ⁻⁹ to 10 ⁺⁹) <i>Press ↵ key to return to Fct. 3.05 "USER UNIT"</i> .
3.06	APPLICAT.	Set overload point for A/D converter
	→ EMPTY PIPE	Switch on "empty tube" identifier option? (appears only when this option is installed) • YES • NO <i>Select with key ↑ or ↓.</i> <i>Press ↵ key to return to Fct. 3.06 "APPLICAT."</i>

4.5 Error messages in measuring mode

The following list gives all errors that can occur during process flow measurement. Errors shown in display when "YES" set in Fct. 1.04 DISPLAY, subfunction "DISP. MSG.".

Error messages	Description of error	Error clearance
LINE INT.	Power failure <u>Note:</u> no counting during power failure	Cancel error in RESET/QUIT. menu Reset totalizer if necessary.
CUR. OUTP. I	Current output overranged.	Check and if necessary correct instrument parameters. After elimination of cause, error message deleted automatically.
PULSOUTP. P	Pulse output overranged. <u>Note:</u> totalizer deviation possible.	Check and if necessary correct instrument parameters. After elimination of cause, error message deleted automatically.
ADC	Analog / digital converter overranged	Error message deleted automatically after elimination of cause.
FATAL. ERROR	Fatal error, all outputs set to "min. values"	Please consult factory.
TOTALIZER	Totalizer has been reset	Cancel error message in RESET/QUIT. menu.
EMPTY PIPE	Pipe has run dry. This message appears only when the " empty pipe identifier " option is installed and the function is switched on under Fct. 3.06 APPLICAT., submenu "EMPTY PIPE".	Fill pipe.

Cancel error messages in RESET / QUIT menu

Key	Display	Description
	-----	----- / ---
↵	CodE 2	--
↑→		ERROR QUIT.
→		QUIT. NO
↑		QUIT. YES
↵		ERROR QUIT.
↵	-----	----- / ---

Reset totalizer(s) in RESET / QUIT menu

Key	Display	Description
	-----	----- / ---
↵	CodE 2	--
↑→		ERROR QUIT.
↑		TOTAL. RESET
→		RESET NO
↑		RESET. YES
↵		RESET QUIT.
↵	-----	----- / ---

Examples of setting the signal converter 4.7

The **cursor**, flashing part of display, is shown below in **bold type**.

- **Change measuring range of current output and value for error messages** (Fct. 1.05):
- Change measuring range from 04-20 mA to **00-20 mA**
- Change value for error messages from 0 mA to **22 mA**

Key	Display	Description
→		If "YES" set under Fct. 3.04 ENTRY CODE, key in the 9-keystroke CODE 1 now: →→→ ↵↵↵ ↑↑↑
→	Fct. 1.00	OPERATION FULL SCALE CURRENT I FUNCT. I RANGE I
→	Fct. 1.01	
4x ↑	Fct. 1.05	
→ ↵		
→	04-20	mA
↑	00-20	mA
↵		I ERROR
→	0	mA
2x ↑	22	mA
↵	Fct. 1.05	CURRENT I OPERATION STORE YES
↵	Fct. 1.00	
↵		
↵	-----	
		----- / ---
		Measuring range with new data for the current output

5 Description of functions

5.1 Full-scale range $Q_{100\%}$

Fct. 1.01 FULL SCALE

Press → key.

Choice of unit for full-scale range $Q_{100\%}$

- **m3/hr** (cubic metres per hour)
- **Liter/Sec** (litres per second)
- **US.Gal/min** (US gallons per minute)
- User-defined unit, factory-set is “**Liter/hr**” (litres per hour) or “**US MGal/day**”, see Sect. 5.12.

Select with ↑ or ↓ key.

Use → key to transfer to numerical setting, 1st number (cursor) flashes.

Set full-scale range $Q_{100\%}$

The setting range is dependent on meter size (DN) and flow velocity (v).

$$Q_{\min} = \frac{\pi}{4} DN^2 \times v_{\min} \quad Q_{\max} = \frac{\pi}{4} DN^2 \times v_{\max} \quad (\text{refer to flow table in Sect. 10.1})$$

0.0053	–	33 929	m ³ /hr
0.00147	–	9 424.5	Liter/Sec
0.00233	–	151 778	US.Gal/min

Change flashing number (cursor) with ↑ or ↓ key.

Use → key to shift cursor 1 place to right.

Press ↵ key to return to Fct. 1.01 FULL SCALE.

Note if “**VALUE P**” is displayed after pressing ↵ key:

PULSE/VOL. is set under Fct. 1.06 PULS B1, subfunction “SELECT P”. Due to the changed full-scale range $Q_{100\%}$, the output frequency (F) of the pulse output will be over- or undershot:

$$P_{\min} = F_{\min} / Q_{100\%} \quad P_{\max} = F_{\max} / Q_{100\%}$$

Change pulse value accordingly, see Sect. 5.7 pulse output B1, Fct. 1.06.

5.2 Time constant

Fct. 1.02 TIMECONST.

Press → key.

Choice

- **ALL** (applies to display and all outputs)
- **ONLY I+S** (applies only to display, current and status output)

Select with ↑ or ↓ key.

Transfer to number setting with ↵ key. 1st number (cursor) flashes.

Set numerical value

- **0.2 - 99.9 Sec** (seconds)

Change flashing number (cursor) with the ↑ or ↓ key.

Use → key to shift cursor 1 place to right.

Press ↵ key to return to Fct. 1.02 TIMECONST.

Fct. 1.03 L.F.CUTOFF

Press → key.

Choice

- **OFF** (fixed trip points: ON = 0.1 % / OFF = 0.2 %, for 100 or 1000 Hz, see Fct. 1.06, 1% or 2%)
- **PERCENT** (variable tripping points: ON = 1 - 19 % / OFF = 2 - 20 %)

Select with ↑ or ↓ key.

Transfer to number setting using → key (only if “PERCENT” selected).
1st number (cursor) flashes.

Setting the numerical value when “PERCENT” selected

- **01 to 19** (cutoff “on” value, left of hyphen)
- **02 to 20** (cutoff “off” value, right of hyphen)

Change flashing number (cursor) with the ↑ or ↓ key.

Shift cursor 1 place to right using → key.

Press ↵ key to return to Fct. 1.03 L.F.CUTOFF.

Note: The cutoff “off” value must be greater than the cutoff “on” value.

Fct. 1.04 DISPLAY

Press → key.

→ **DISP. FLOW = select unit for display of flowrate, press → key**

- **NO DISP.** (no display)
- **m3/hr** (cubic metres per hour)
- **Liter/Sec** (litres per second)
- **US.Gal/min** (US gallons per minute)
- user-defined unit, factory-set: “**Liter/hr**” (litres per hour) or “**US MGal/day**”, see Sect. 5.14
- **PERCENT** (percentage display)
- **BARGRAPH** (numerical value and bar graph display in %)

Select with ↑ or ↓ key.

Press ↵ key to transfer to subfunction “DISP. TOTAL”.

→ **DISP. TOTAL = select unit for totalizer display, press → key**

- **NO DISP.** (no display)
- **OFF** (internal totalizer switched off)
- **+ TOTAL.** • **- TOTAL.** • **+/- TOTAL.** • **SUM (Σ)** • **ALL (sequential)**

Select with ↑ or ↓ key.

Transfer to totalizer unit setting using ↵ key.

- **m3** (cubic metres)
- **Liter** (litres)
- **US.Gal** (US gallons)
- user-defined unit, factory-set: “**Liter**” or “**US MGal**”, see Sect. 5.14

Select with ↑ or ↓ key.

Transfer to totalizer format setting using → key.

Setting of totalizer format

- **Auto** (exponent notation)
- # . ##### • ##### . ###
- ## . ##### • ##### . ##
- ### . ##### • ##### . #
- #### . ##### • #####

Select with key ↑ or ↓.

Press ↵ key to transfer to subfunction "DISP. MSG".

→ **DISP. MSG. = additional messages required in measuring mode, press → key**

- **NO** (no other messages)
- **YES** (display other messages, e.g. errors, in sequence with the measured values)

Select using the ↑ or ↓ key.

Press ↵ key to return to Fct. 1.04 DISPLAY.

Note: "BUSY" is displayed in the measuring mode when all displays are set to "NO DISP." or "NO". Sequencing of displays is automatic. However, in the measuring mode, manual sequencing can be carried out with the ↑ key. Return to automatic sequencing after approx. 3 minutes.

Please refer to Sect. 3.2 "factory settings"

5.5 Internal electronic totalizer

The internal electronic totalizer counts in m³, regardless of the unit set under Fct. 1.04, subfunction "DISP. FLOW".

The counting range is dependent upon the meter size and has been selected such that the totalizer will count for a minimum of 1 year without overflow:

Meter size		Counting range	
DN mm	inch	in m ³	US Gal equivalent
10 - 50	³ / ₈ - 2	0 - 999 999.9999999	0 - 264 172 052.35800
65 - 200	2 ¹ / ₂ - 8	0 - 9 999 999.9999999	0 - 2 641 720 523.5800
250 - 600	10 - 24	0 - 99 999 999.9999999	0 - 26 417 205 235.800
700 -1000	28 - 40	0 - 999 999 999.999999	0 - 264 172 052 358.00

Only part of the totalizer count is shown in the display because it is not possible to output a 14-digit number. Unit and format of the display are freely selectable, see Fct. 1.04, subfunction "DISP. TOTAL" and Sect. 5.4. This determines which part of the count is to be displayed. Display overflow and totalizer overflow are independent of one another.

Example

Internal count	0000123 . 7654321	m ³
Format, display unit	XXXX . XXXX	Liter
Internal count in unit	0123765 . 4321000	Liter
Displayed	3765 . 4321	Liter

Fct. 1.05 CURRENT I

Press → key.

→ **FUNCT. I = select function for current output, press → key**

- **OFF** (switched off, no function)
- **1 DIR.** (1 flow direction)
- **2 DIR.** (2 flow directions, F/R mode, forward/reverse)

Select using ↑ or ↓ key.

Transfer to subfunction "RANGE I" with ↵ key.

Exception: When "OFF" selected, return to Fct. 1.05 CURRENT I.

→ **RANGE I = select measuring range, press → key**

- **0 - 20 mA**
- **4 - 20 mA** fixed ranges

Press → key to transfer to number setting.

Select with key ↑ or ↓.

Press key ↵ to transfer to subfunction "I ERROR".

→ **I ERROR = set error value, press → key**

- **0 mA**
- **3.6 mA** (only possible if range "4-20 mA" selected)
- **22 mA**

Select using key ↑ or ↓. Press → key to transfer to number setting.

Press key ↵ to return to Fct. 1.05 CURRENT I.

Please refer to Sect. 3.2 "Factory settings".

Refer to Sect. 2.3 for connection diagrams, and to Sect. 5.14 for characteristics.

5.7 Pulse output P

NOTE! Check whether under Fct. 3.07 "HARDWARE" the output terminal "B1" is defined as pulse output, refer also to Sect. 2.2 and Sect. 5.16.

Fct. 1.06 PULS.OUTP. P

Press key → .

→ **FUNCT. P = select function for pulse output, press → key**

- **OFF** (switched off, no function)
- **1 DIR.** (1 flow direction)
- **2 DIR.** (2 flow directions, F/R mode, forward/reverse)

Select with key ↑ or ↓.

Press ↓ key to transfer to subfunction "SELECT P".

Exception: When "OFF" selected, return to Fct. 1.06 PULS B1.

→ **SELECT P = select pulse type, press → key**

- **100 Hz**
- **1000 Hz**
- **PULSE/VOL.** (pulses per unit volume, flow)
- **PULSE/ZEIT** (pulses per unit time for 100% flow)

Select using ↑ or ↓ key.

Transfer to subfunction "PULSWIDTH" with ↓ key.

Note: when 100 Hz or 1000 Hz selected, return to Fct. 1.06 PULS.OUTP. P.

→ **PULSWIDTH = set pulse width, press → key**

- **50 mSec** $F_{max} = 10 \text{ Hz}$ $F_{min} = 0.0056 \text{ Hz}$ (= 20 Pulse / hr)
- **100 mSec** = 5 Hz
- **200 mSec** = 2.5 Hz
- **500 mSec** = 1 Hz
- **1 Sec** = 0,5 Hz

Select using ↑ or ↓ key.

Transfer to subfunction "VALUE P" with ↓ key or return to Fct. 1.06

PULS.OUT. P, depending on choice of pulse type in subfunction "SELECT P".

→ **VALUE P = set pulse value per unit volume**

(appears only when "PULSE/VOL." set under "SELECT P"),_press → key.

- **XXXX PulS/m3**
- **XXXX PulS/Liter**
- **XXXX PulS/US.Gal**
- **XXXX PulS/** user unit, factory-set: "Liter" or "US MGal", see Sect. 5.12.

Select using ↑ or ↓ key.

Transfer to number setting with → key. 1st digit (cursor) flashes.

Set numerical value

- **XXXX** (setting range depends on pulse width and full-scale range: $P_{\min} = F_{\min} / Q_{100\%}$ $P_{\max} = F_{\max} / Q_{100\%}$)

Change flashing digit (cursor) with ↑ or ↓ key,

shift cursor 1 place to right or left with → key.

Press ↵ key to return to Fct. 1.06 PULS.OUTP. P.

or

→ **VALUE P = set pulse value per unit time,**

(appears only when "PULSE/TIME" has been set under "SELECT P"),_press → key.

- **XXXX PulSe/Sec**
- **XXXX PulSe/min**
- **XXXX PulSe/hr**
- **XXXX PulSe/** user unit, factory-set: "hr", or "day", see Sect. 5.12.

Select using ↑ or ↓ key.

Transfer to number setting with → key, 1st digit (cursor) flashes.

Set numerical value

- **XXXX** (setting range depends on pulse width)

Change flashing digit (cursor) with ↑ or ↓ key,

shift cursor 1 place to right or left with → key.

Press ↵ key to return to Fct. 1.06 PULS.OUTP. P.

Please refer to Sect. 3.2 "factory settings"

Refer to Sect. 2.3 for connection diagrams, and to Sect. 5.14 for characteristics.

5.8 Status output S

Fct. 1.07 IND. OUTP. S

Press key → .

Select function of status outputs, press → key

- **ALL ERROR** (indicates all errors)
- **FATAL.ERROR** (indicates fatal errors only)
- **OFF** (switched off, no function)
- **ON** (indicates that flowmeter is operative)
- **F/R INDIC.** (indicates direction for current and pulse outputs, F/R mode)
- **EMPTY PIPE** (option "empty tube identification")
- **TRIP. POINT** (setting range: 002 – 115 PERCENT of $Q_{100\%}$, full-scale range)
*Transfer to number setting with ↵ key, 1st digit (cursor) flashes.
 Change flashing digit (cursor) with ↑ and ↓ keys. Use →
 and ← keys to shift cursor 1 place to right or left.*

Press ↵ key to return to Fct. 1.07 IND. OUTP. S.

Characteristic of status output	Switch open	Switch closed
OFF (switched off)	no function	
ON (e.g. operation indicator)	power OFF	power ON
F/R INDIC.	Forward flow	Reverse flow
TRIP POINT (limit switch)	inactive	active
ALL ERROR (all errors)	errors	no error
FATAL.ERROR (fatal errors only)	errors	no error
EMPTY PIPE (option)	when measuring tube is empty	when measuring tube is full

Please refer to Sect. 3.2 "factory settings"

Refer to Sect. 2.3 for connection diagrams, and to Sect. 5.14 for characteristics.

Fct. 3.01 LANGUAGE

Press → key.

Select language for texts in display

- **D** (German)
- **GB/USA** (English)
- **F** (French)
- others on request

Select using ↑ key.

Press ↵ key to return to Fct. 3.01 LANGUAGE.

Fct. 3.04 ENTRY CODE

Press → key.

Choice

- **NO** (no code, enter setting mode with → key)
- **YES** (enter setting mode with → key and Code 1: → → → ↵ ↵ ↵ ↑ ↑ ↑)

Select using ↑ key.

Press ↵ key to return to Fct. 3.04 ENTRY CODE.

5.11 Primary head

Fct. 3.02 FLOW METER

Press → key.

→ **DIAMETER = set meter size** (see instrument nameplate), *press* → key

Select size from table of meter sizes:

- DN 2.5 - 1000 mm equivalent to 1/10 - 40 inch

Select using ↑ or ↓ key.

Transfer to subfunction "FULL SCALE" with ↵ key.

→ **FULL SCALE = set full-scale range**, *press* → key.

Set as described in Sect. 5.1.

Transfer to subfunction "GKL VALUE" with ↵ key.

Note: if "VALUE P" is displayed after pressing ↵ key.

PULSE/VOL. is set under Fct. 1.06 PULS.OUTP. P, subfunction "SELECT P". Because the full-scale range $Q_{100\%}$ has been changed, the output frequency (F) of the pulse output is over- or undershot:

$$P_{\min} = F_{\min} / Q_{100\%} \quad P_{\max} = F_{\max} / Q_{100\%}$$

Change pulse value accordingly, see Sect. 5.7 pulse output P, Fct. 1.06.

→ **GKL VALUE = set primary constant GK**, *press* → key.

- 1.0000 - 9.9999 (note information on instrument nameplate, do **not** change setting !)

Change flashing digit (cursor) with ↑ or ↓ key.

Shift cursor 1 place to right or left with → or ← key.

Transfer to subfunction "FIELD FREQ." with ↵ key.

→ **FIELD FREQ. = set magnetic field frequency**, *press* → key

- 1/6 } (1/6 or 1/18 of power frequency, see instrument nameplate, do **not** change setting)
- 1/18 }

Select using ↑ or ↓ key.

Transfer to subfunction "FLOW DIR." with ↵ key.

(only for units with DC power supply, transfer to subfunction "LINE FREQ").

→ **LINE FREQ. = normal line frequency in your country**, *press* → key.

- 50 Hz Select using the ↑ key.
- 60 Hz Transfer to subfunction "FLOW DIR." with ↵ key.

→ **FLOW DIR. = set flow direction**, *press* → key.

- + DIR. (for identification of flow direction, see "+" arrow on primary head;
- - DIR. for F/R mode, identifies the "positive" flow direction)

Select using the ↑ or ↓ key.

Press ↵ key to return to Fct. 3.02 FLOW METER.

Zero check, see Fct. 3.03 and Sect. 7.1.

Please refer to Sect. 3.2 "factory settings"

Fct. 3.05 USER UNIT

Press → key.

→ **TEXT VOL = set text for user-defined unit, press → key**

- **Liter** (max. 5 characters, factory-set: "Liter" or "US MGal")
Characters assignable to each place: **A-Z, a-z, 0-9**, or "-" (= blank character)

Change flashing place (cursor) using ↑ or ↓ key.

Use → or ← key to shift cursor 1 place to right or left.

Transfer to subfunction "FACT. VOL." with ↵ key.

→ **FACT. VOL. = set factor F_M for volume, press → key**

- **1.00000 E+3** (factory-set: "10³ or 2.64172 x 10⁻⁴" / factor F_M = volume per 1 m³)
Setting range: 1.00000 E-9 to 9.99999 E+9 (= 10⁻⁹ to 10⁺⁹)

Change flashing place (cursor) using ↑ or ↓ key..

Use → or ← key to shift cursor 1 place to right or left.

Transfer to subfunction "TEXT TIME" with ↵ key.

→ **TEXT TIME = set text for required time, press → key**

- **hr** (max. 3 places, factory-set: "hr = hour" or "day")
Characters assignable to each place: **A-Z, a-z, 0-9**, or "-" (= blank character)

Change flashing place (cursor) using ↑ or ↓ key.

Use → or ← key to shift cursor 1 place to right or left.

Transfer to subfunction "FACT. TIME" with ↵ key.

→ **FACT. TIME = set factor F_T for time, press → key**

- **3.60000 E+3** (factory-set: "3.6 x 10³" for hour or "8.64 x 10⁴" for day / set factor F_T in seconds)
Setting range: 1.00000 E-9 to 9.99999 E+9 (= 10⁻⁹ to 10⁺⁹)

Change flashing place (cursor) using ↑ or ↓ key.

Use → or ← key to shift cursor 1 place to right or left.

Press ↵ key to return to Fct. 3.05 USER UNIT.

Factors for volume F_M (factor F_M = volume per 1 m³)

Volumetric unit	Text examples	Factor F _M	Setting
Cubic metres	m3	1.0	1.00000 E+0
Litres	Liter	1 000	1.00000 E+3
Hectolitres	h Lit	10	1.00000 E+1
Decilitres	d Lit	10 000	1.00000 E+4
Centilitres	c Lit	100 000	1.00000 E+5
Millilitres	m Lit	1 000 000	1.00000 E+6
US gallons	USGal	264.172	2.64172 E+2
Millions US gallons	USMG	0.000264172	2.64172 E-4
Imperial gallons	GBGal	219.969	2.19969 E+2
Mega imperial gallons	GBMG	0.000219969	2.19969 E-4
Cubic feet	Feet3	35.3146	3.53146 E+1
Cubic inches	inch3	61 024.0	6.10240 E+4
US barrels liquid	US BaL	8.36364	8.38364 E+0
US barrels ounces	US BaO	33 813.5	3.38135 E+4

Factors for time F_T (factor F_T in seconds)

Time unit	Text examples	Factor F _T (seconds)	Setting
Seconds	Sec	1	1.00000 E+0
Minutes	min	60	6.00000 E+1
Hours	hr	3 600	3.60000 E+3
Day	DAY	86 400	8.64000 E+4
Year (= 365 days)	YR	31 536 000	3.15360 E+7

5.13 F/R mode, forward/reverse flow measurement

- Refer to Sect. 2.6 for electrical connection of outputs.
- Define direction of forward (normal) flow, see Fct. 3.02, subfunction "FLOW DIR.": in conjunction with F/R operation, set the direction for the forward flow here. "+" signifies the same direction as shown by the arrow on the primary head, "-" signifies the opposite direction.
- Set the status output to "F/R INDIC.," see Fct. 1.07.
- Current and/or pulse output must be set to "2 DIR.," see Fct. 1.05 and 1.06, subfunctions "FUNCT. I" and "FUNCT. B1".

5.14 Characteristic of outputs

I	Current output
I_{0%}	0 or 4 mA
I_{100%}	20 mA
P	Pulse output
P_{100%}	Pulses at Q _{100%} , full-scale range
Q_F	1 flow direction, forward flow in F/R operation
Q_R	Reverse flow in F/R operation
Q_{100%}	Full-scale range
S	Status output
	switch open
	switch closed

1 flow direction

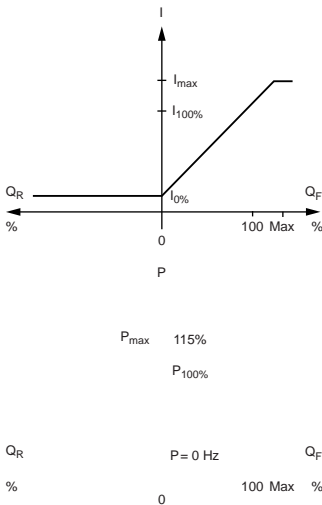

2 flow directions, F/R operation

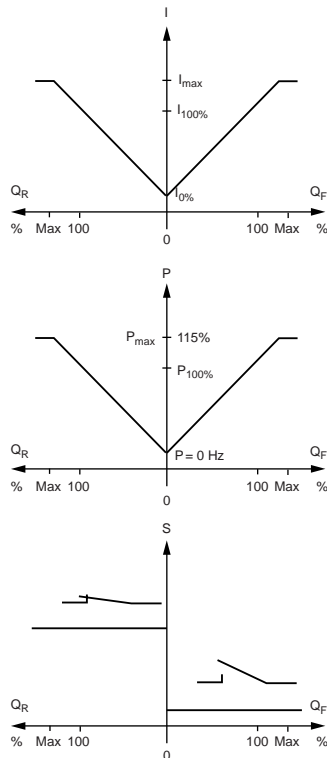

Fct. 3.07 APPLICAT.

Press key → .

→ **EMPTY PIPE**, "function switch on".

- **YES**
- **NO** select with ↑ or ↓ key.

Press ↵ key to return to Fct. 3.07 APPLICAT.

Here you can note down the settings of the signal converter !

Fct. No.	Function	Settings
1.01	Full-scale range	
1.02	Time constant	
1.03	Low-flow cut-off	- ON: - OFF:
1.04	Display	Flow
		Totalizer
		Messages
1.05	Current output I	Function
		Range I
		Error
1.06	Pulse output P	Function
		Selection
		Pulse width
		Value
1.07	Status output S	
3.01	Language	
3.02	Primary head	Meter size
		GKL value
		Field frequency
		Power frequency
		Flow direction
3.04	Entry code required ?	- no - yes
		→ → → ↵ ↵ ↵ ↑ ↑ ↑
3.05	User-defined unit	

Part C Special applications, functional checks, service, and order numbers

6 Special applications

6.1 HHT 010 hand held terminal and RS 232 adapter incl. CONFIG software (options)

External operator control can be carried out with the following options:

- HHT 010 hand-held terminal **only** for IFC 010 – / **B** signal converter (basic version)
- MS-DOS PC via an RS 232 adapter, incl. CONFIG software for signal converter IFC 010 – / **B** (basic version) and IFC 010 – / **D** (display version)
Detailed directions supplied.

Switch off power source before opening the housing !

- 1) Unscrew the 4 recessed head screws and remove the transparent cover.
- 2) Plug the HHT connection plug **or** the RS 232 adapter into the IMoCom Bus socket and connect to the PC or laptop, see amplifier PCB in Sect. 8.9.
- 3) Switch on the power.
- 4) As described in the supplied description, change data, parameters and measured values, and have them called up for display.
- 5) Switch off the power.
- 6) Pull the HHT plug **or** the RS 232 adapter off the amplifier PCB.
- 7) Replace transparent cover and tighten down the 4 recessed head screws.

Please refer to Sect. 3.2 “factory settings”

Output signals can be stabilized to values as for “zero” flow to prevent random output signals when the measuring tube is empty or when the electrodes are not wetted in the event the measuring tube is partially full.

Display: 0
 Current output: 0 or 4 mA, see setting in Fct. 1.05.
 Pulse output: no pulses (= 0 Hz), see setting in Fct. 1.06.

Precondition:

- electrical conductivity of product $\geq 200 \mu\text{S/cm}$ ($\mu\text{mho/cm}$), $\geq 500 \mu\text{S/cm}$ for meter sizes DN 10 - 15 and 3/8" - 1/2"
- length of signal cable $\leq 10 \text{ m} / \leq 30 \text{ ft}$ and free of vibration at field signal converter
- process products are homogeneous, free from solids and gas inclusions, and do not tend to cause electrical or catalytic reactions.

Changes on amplifier PCB, see illustration in Sect. 8.9.

Switch off power source before opening the housing !

Refer to Sect. 8.5 for Fig. A, B and D.

- 1) Unscrew the 4 recessed head screws (**Fig. A**) and remove transparent cover.
- 2) Unscrew recessed head screw (**Fig. B**) and remove black plastic cover.
- 3) Unscrew the 2 recessed head screws (**Fig. D**) and remove black metal cover.
- 4) If display unit provided, unscrew the 4 recessed head screws and fold display carefully to side.
- 5) Join the two “semicircles” of points **S3** and **S6** on the amplifier PCB with tin solder, see figure in Sect. 8.9.
- 6) Reassemble in reverse order, Items 4) to 2) above.
- 7) Switch on power.
- 8) Check setting of the low-flow cutoff SMU, Fct. 1.03, and reset if necessary:

L.F.CUTOFF switched on, range:

Full scale range $Q_{100\%}$		Cutoff values	
		... OFF ON ...
> 3 m/s	> 10 ft/s	> 2 %	1 %
1 - 3 m/s	3 -10 ft/s	> 6 %	4 %
< 1 m/s	< 3 ft/s	>10 %	8 %

Operator control:

Display Version: (**D**), see Sect. 4 and 5.3, Fct. 1.03

Basic Version: (**B**), see Sect. 6.1.

- 9) After checking and/or resetting, replace transparent cover and tighten down the 4 recessed head screws.

7. Functional checks

7.1 Zero check with IFC 010 ___ / D signal converter, Fct. 3.03

Switch off power source before opening the housing

- Set “zero” flow in the pipeline, but make sure that the measuring tube is completely filled with fluid.
- Switch on the system and wait 15 minutes.
- Press the following keys for zero measurement:

Key	Display		Description
→			If “YES” set under Fct. 3.04 ENTRY CODE, key in 9-keystroke CODE 1 now: → → → ↓ ↓ ↓ ↑ ↑ ↑
2x ↑	Fct. 1.00	OPERATION	
→	Fct. 3.00	INSTALL.	
2x ↑	Fct. 3.01	LANGUAGE	
→	Fct. 3.03	ZERO SET	
→		CALIB. NO	Flowrate displayed in set unit, see Fct. 1.04 DISPLAY, subfunction “DISP. FLOW”. Zero measurement in progress, duration approx. 50 seconds. When flow “> 0” “WARNING” notice appears, confirm with ↓ key. If new value not to be stored, press ↓ key (3x) 4x = return to measuring mode.
↑		CALIB. YES	
↓	0.00	----- / ---	
		STORE NO	
↑		STORE YES	
↓	Fct. 3.03	ZERO SET	
(2x) 3x ↓	-----	----- / ---	

7.2 Test of measuring range Q, Fct. 2.01

Switch off power source before opening the housing !

- For this test a measured value can be simulated in the range of -110 to +110 percent of $Q_{100\%}$ (full-scale range set, see Fct. 1.01 FULL SCALE).
- Switch on the system.
- Press the following keys for this test:

Key	Display		Description
→			If “YES” set under Fct. 3.04 ENTRY CODE, key in 9-keystroke CODE 1 now: → → → ↓ ↓ ↓ ↑ ↑ ↑
↑	Fct. 1.00	OPERATION	
→	Fct. 2.00	TEST	
→	Fct. 2.01	TEST Q	
↑		SURE NO	
		SURE YES	Current, pulse and status indication outputs indicate the corresponding values. Select using ↑ or ↓ key
↓	0	PERCENT	
	± 10	PERCENT	
↑	± 50	PERCENT	
	± 100	PERCENT	
	± 110	PERCENT	
↓	Fct. 2.01	TEST Q	
(2x) 3x ↓	-----	----- / ---	

Switch off power source before opening the housing !

- Before consulting factory about errors or flow measurement problems, please invoke Fct. 2.02 HARDW. INFO (hardware information).
- An 8-character and a 10-character status code are stored under this function in each of 3 "windows". These 6 status codes allow rapid and simple diagnosis of your compact flowmeter.
- Switch on system.
- Press the following keys for display of the status codes:

Key	Display	Description	
→ ↑ → ↑	Fct. 1.00 Fct. 2.00 Fct. 2.01 Fct. 2.02	OPERATION TEST TEST Q HARDW. INFO	If "YES" set under Fct. 3.04 ENTRY CODE, key in the 9-keystroke CODE 1 now: → → → ↓ ↓ ↓ ↑ ↑ ↑
→	→ MODUL ADC -----	-----	1st window
↓	→ MODUL IO -----	-----	2nd window
↓	→ MODUL DISP. -----	-----	3rd window
PLEASE NOTE DOWN ALL 6 STATUS CODES !			
↓ (2x) 3x ↓	Fct. 2.02 -----	HARDW. INFO ----- / ---	Terminate hardware information Measuring mode

If you need to return your flowmeter to Krohne, please refer to last but one page of these Instructions !

7.4 Faults and symptoms during start-up and process flow measurement

- Most faults and symptoms occurring with the compact flowmeters can be eliminated with the aid of the following tables.
- For greater clarity, faults and symptoms in the tables are divided into 2 parts and various groups.
- **Part 1** Signal converter **IFC 010 B** (B = basic version), **without** display **and without** HHT or CONFIG user program (see Sect. 6.1)
Groups: **LED** LED display (status messages)
 I Current output
 P Pulse output
 LED / I / P LED display, current output and pulse output
- **Part 2** Signal converter **IFC 010 D** (D = display version) and Signal converter **IFC 010 B** (B = basic version), **without** display **but with** CONFIG user program (see Sect. 6.1)
Groups: **D** Display
 I Current output
 P Pulse output
 S Status indication output
 D / I / P / S LED display, current output, status output

Before contacting Krohne Service, please read through the following tables. THANK YOU !

Part 1		Converter IFC 010 B (B = basic version), without display and without HHT or CONFIG operator program	
Group LED	Fault / Symptom	Cause	Remedial action
LED 1	LED flashes red/green	Overranging of A/D converter, current or pulse output	Reduce flowrate; if unsuccessful, test as described in Sect. 7.5.
		Measuring tube drained, A/D converter overranged.	Fill measuring tube.
LED 2	LED flashes red	Fatal Error, hardware and/or software error	Replace signal converter (see Sect. 8.4) or contact Krohne Service.
LED 3	cyclic flashing of red LED, approx 1 second	Hardware fault, Watchdog activated.	Replace signal converter (see Sect. 8.4) or contact Krohne Service.
LED 4	LED shows red continuously	Hardware fault	Replace signal converter (see Sect. 8.4) or contact Krohne Service.

Part 1 (cont'd)	Converter IFC 010 B (B = basic version), without display and without HHT or CONFIG operator program		
Group I	Fault / Symptom	Cause	Remedial action
I 1	Receiver instrument indicates "0".	Connection/polarity incorrect.	Connect properly as described in Sect. 2.3.
		Receiver instrument defective.	Check connecting cables and receiver instrument, and replace if necessary.
		Short between current output and pulse output	Check connections and cables, see Sect. 2.3, voltage between I+ and I.L approx. 15 V. Switch off device, eliminate short-circuit, switch device on.
		Current output defective	Replace signal converter (see Sect. 8.4) or contact Krohne Service.
I 2	22 mA present at current output (fault current)	Current output I overranged	Check device parameters and change if necessary, see Sect. 6.1, or contact Krohne Service
I 3	22 mA present at current output (fault current) and red LED shows.	Fatal Error	Replace signal converter (see Sect. 8.4) or contact Krohne Service
I 4	Unsteady display	<ul style="list-style-type: none"> – Process product conductivity too low, particles/air inclusions too large or inhomogeneous – Pulsating flow – Time constant too low 	Increase time constant, see Sect. 6.1, or contact Krohne Service.
Group P	Fault / Symptom	Cause	Remedial action
P 1	Connected totalizer not counting any pulses	Connection/polarity incorrect	Connect properly as described in Sect. 2.3
		Totalizer or external voltage source defective	Check connection cables, totalizer and external voltage source, and replace if necessary.
		Current output is external voltage source; short-circuit, or current/pulse output defective.	Check connection and cables (see Sect. 2.3), voltage between I+ and I.L approx. 15 V. Switch off device. Eliminate short-circuit and switch device on again. If no function then current or pulse output defective. Replace signal converter (see Sect. 8.4) or contact Krohne Service.
		Pulse output inactive, see Fct. 1.06 and report on settings.	Switch on, see Sect. 6.1, or contact Krohne Service.
		Fatal Error, red LED shows.	Replace signal converter (see Sect. 8.4) or contact Krohne Service.
P 2	Unsteady pulse rate	<ul style="list-style-type: none"> – Process product conductivity too low, particles/air inclusions too large or inhomogeneous – Pulsating flow – Time constant too low or switches off 	Increase or switch on time constant, see Sect. 6.1, or contact Krohne Service.
Group LED / I / P	Fault / Symptom	Cause	Remedial action
LED / I / P 1	Red LED flashes, current output indicates fault current and pulse output "0".	Fatal Error, hardware fault and/or software error	Replace signal converter (see Sect. 8.4) or contact Krohne Service.

Part 2	Signal converter IFC 010 D (D = display version) and Signal converter IFC 010 B (B = basic version), without display but with HHT or CONFIG operator program (see Sect. 6.1)		
Group D	Display shows . . .	Cause	Remedial action
D 1	LINE INT.	Power failure. <u>Note:</u> no counting during power failure.	Delete error message in RESET/QUIT. menu. Reset totalizer(s) if need be.
D 2	CUR.OUTP. I	Current output overranged.	Check instrument parameters and correct if necessary. Error message deleted automatically after cause has been eliminated.
D 3	PULS.OUTP. P	Pulse output overranged. <u>Note:</u> totalizer deviation possible	Check instrument parameters, correct if necessary, and reset totalizer(s). Error message deleted automatically after cause has been eliminated.
D 4	ADC	Analog/digital converter overranged.	Error message deleted automatically after cause has been eliminated.
D 5	FATAL. ERROR	Fatal Error, all outputs set to "min." values.	Replace signal converter (see Sect. 8.4) or contact Krohne Service, having first noted down hardware information and error status, see Fct. 2.02.
D 6	TOTALIZER	Counts lost (overflow, data error)	Delete error message in RESET/QUIT. menu.
D 7	„STARTUP“ cyclic flashing	Hardware fault, Watchdog activated.	Replace signal converter (see Sect. 8.4) or contact Krohne Service.
D 8	BUSY	Displays for flow, totalizers and errors disabled.	Change setting in Fct. 1.04.
D 9	Unsteady display	– Process product conductivity too low, particles/air inclusions too large or inhomogeneous – Pulsating flow – Time constant too low	Increase time constant, see Sect. 6.1, or contact Krohne Service.
D 10	No display	Power OFF.	Switch on power
		Check power fuse(s) F1 (F1 and F2 with DC).	Replace if defective (see Sect. 8.2).
Group I	Fault / Symptom	Cause	Remedial action
I 1	Receiver instrument indicates "0".	Incorrect connection/polarity	Connect properly, see Sect. 2.3.
		Receiver instrument or current output defective.	Check output (see Sect. 7.2) with new milliammeter: <u>Test ok</u> , check connection cables and receiver instrument, replace if necessary. <u>Test faulty</u> , current output defective. Replace signal converter (see Sect. 8.4) or contact Krohne Service
		Current output disabled, see Fct. 1.05	Activate under Fct. 1.05.
		Short-circuit between current output and pulse output.	Check connection and cables, see Sect. 2.3. Voltage between I+ and I.L. approx. 15 V. Switch off device, eliminate short-circuit, and switch device on again.
I 2	Unsteady display	– Process product conductivity too low, particles/air inclusions too large or inhomogeneous – Pulsating flow – Time constant too low	Increase time constant, see Sect. 6.1, or contact Krohne Service.

Part 2 (cont'd)		Signal converter IFC 010 D (D = display version) and Signal converter IFC 010 B (B = basic version), without display but with HHT or CONFIG operator program (see Sect. 6.1)	
Group P	Fault / Symptom	Cause	Remedial action
P 1	Totalizer connected but does not count any pulses	Incorrect connection/polarity	Connect properly, see Sect. 2.3
		Totalizer or external voltage source defective.	Check output (see Sect. 7.2) with new totalizer: <u>Test ok</u> , check connection cables and previous totalizers and external voltage source, and replace if necessary. <u>Test faulty</u> , pulse output defective, replace signal converter (see Sect. 8.4) or contact Krohne Service.
		Current output is external voltage source, short circuit or current / pulse output defective	Check connection and cables, see Sect. 2.3. Voltage between I+ and I- approx. 15 V. Switch off device, eliminate short circuit, switch device on again. If no function, then current or pulse output defective. Replace signal converter (see Sect. 8.4) or contact Krohne Service.
		Pulse output is deactivated, see Fct. 1.06.	Switch on under Fct. 1.06.
P 2	Unsteady pulse rate	– Process product conductivity too low, particles/air inclusions too large or inhomogeneous – Pulsating flow – Time constant too low or switched off	Increase or switch on time constant, see Sect. 6.1, or contact Krohne Service.
P 3	Pulse rate too high or too low.	Incorrect setting for pulse output.	Change setting under Fct. 1.06.
Group S	Fault / Symptom	Cause	Remedial action
S 1	No function	Incorrect connection/polarity of status display	Connect properly, see Sect. 2.3.
		Status display or output defective or external voltage source not supplying voltage.	Set status output under Fct. 1.07 to "F/R INDIC." (flow direction) and check (see Sect. 7.2) with new status display: <u>Test ok</u> , check previous status display and external voltage source, and replace if necessary. <u>Test faulty</u> , status output defective, replace signal converter (see Sect. 8.4) or contact Krohne Service.
Group D/I/P/S	Fault / Symptom	Cause	Remedial action
D / I / P / S 1	Unsteady display and outputs	– Process product conductivity too low, particles/air inclusions too large or inhomogeneous – Pulsating flow – Time constant too low	Increase time constant, see Sect. 6.1, or contact Krohne Service.
D / I / P / S 2	No display and no function of outputs	Power OFF	Switch power on.
		Check power fuse(s) F1 (F1 and F2 for DC).	Replace if defective, see Sect. 8.2.

7.5 Test of primary head

Always switch off power source before opening the housing !

Required measuring instruments and tools

- A crosstip screwdriver
- Ohmmeter with at least 6 V range

or AC voltage/resistance measuring bridge.

Note: Accurate measurements in the area of the electrodes can only be obtained with an AC voltage/resistance bridge. Also, the measured resistance is very heavily dependent on the electrical conductivity of the liquid product.

Preparatory work

- **Switch off power source.**
- Remove transparent cover (unscrew 4 recessed head screws) and black plastic cover (unscrew 1 recessed head screw), see **Fig. A** and **B** in Sect. 8.5.
- Detach blue 9-pin plug, see **Fig. D** in Sect. 8.5, field power supply (pins 7+8) and signal cables (pins 1, 2, 3, 4 +5).
- Completely fill the measuring tube of the flowmeter with the process liquid.

Blue 9-pin plug
(connection to primary head)

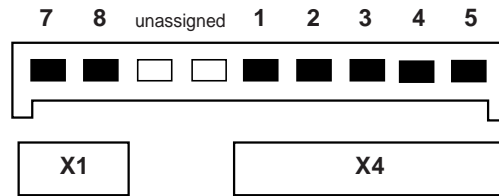

Jacks X1 and X4 on amplifier PCB, see Sect. 8.9

Action		Typical result	Incorrect result = flowmeter defective, return to factory for repair, refer to last but one page !
1	Measure resistance between wires 7 and 8 .	30 - 150 Ω	if lower: interwinding fault
			if higher: wire break
2	Measure resistance between U-clamp terminal in terminal compartment (PE protective conductor or FE functional ground) and wires 7 and 8	> 10 MΩ	if lower: interwinding fault to PE or FE.
3	Measure resistance between wires 1 and 3 and between 1 and 4 (same measuring lead always on wire 1 !)	1 kΩ - 1 MΩ (see "Note" above). Both values should be approx. equal.	if lower: drain measuring tube and repeat measurement; if still too low, short-circuit in electrode wires.
			if higher: break in electrode wires or electrodes contaminated.
			Values not equal: break in electrode wires or electrodes contaminated.

Always switch off power source before opening the housing !

Required measuring instruments and tools

Multimeter, DC and AC voltage, > 20 kohms / V
Crosstip screwdriver

Preparatory work

- Switch off power source.
- Remove transparent cover (unscrew 4 recessed head screws) and black plastic cover (unscrew 1 recessed head screw), see **Fig. A and B** in Sect. 8.5.
- If provided, remove display PCB, see Sect. 8.7.
- Switch power source on again.

Measuring and test points on amplifier PCB, see Sect. 8.9

MP = measuring point
TP = test point
X1 = socket connector, 20-pin
X3, X5 = plug connector

Please note: When carrying out measurements, do **not** produce any short-circuits between the components !

Action		Typical result	Faulty result
Voltage measurements on amplifier PCB, see Sect. 8.9			
1	between TP 1 (solder pin) and Pin 11 of X1	15 . . . 30 V DC	If measured voltages lower, <u>signal converter defective</u> , replace, see Sect. 8.4, or contact Krohne Service.
2	between TP 1 (solder pin) and Pin 9 of X1	30 . . . 40 V DC	
3	between MP 5 (solder pin) and Pin 15 of X1	19 . . . 26 V DC	
4	between MP 5 (solder pin) and Pin 18 of X1	-20 . . . -27 V DC	
5	field current supply between Pin 7 and Pin 8 of X3	> 1.5 V AC	
6	input voltage between MP 1 and MP 5	-10 . . . +10 V DC	If outside range, input amplifier overranged, measuring tube empty or primary head defective; check acc. to Sect. 7.5.
7	Short Pin 1, 2 and 3 of X5 , measure input voltage between MP 1 and MP 5	-10 . . . +10 V DC	If outside range, signal converter defective.

Note: A thermostatic switch is installed in the transformers of the AC versions. In the DC version, the PCB is equipped with a thermofuse. All signal converters contain PTR fusible links (typically 100 overload cycles). This allows cyclic switching on and off of the signal converter under overload conditions. The cool-down phase may be anything up to one hour.

7.7 Test of signal converter using GS 8 A simulator (option)

GS 8 A operating elements and accessories

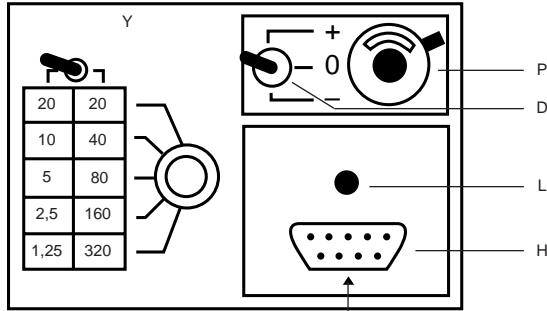

- A** 5-to-3 pin adapter for cable **C5**
- B** Plug for field power supply, 2-pin
- C3/C5** Plug for signal cable, 3-pin / 5-pin
- D** Switch, flow direction
- H** Socket for **H2** plug on cable **Z**
- H2** Plug of cable **Z**
- L** Power supply ON
- P** Potentiometer "zero"
- X3** Socket for plug **B** on amplifier PCB
- X5** Socket for plug **C3** on amplifier PCB
- Y** Switch, measuring ranges
- Z** Cable between GS 8 A and signal converter

Electrical connection

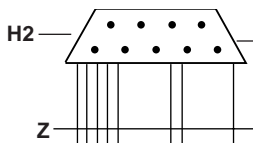

Using GS 8 simulator
Additional adapter is required between GS 8 and IFC 010 signal converter.
Order No. 2.10764.00.

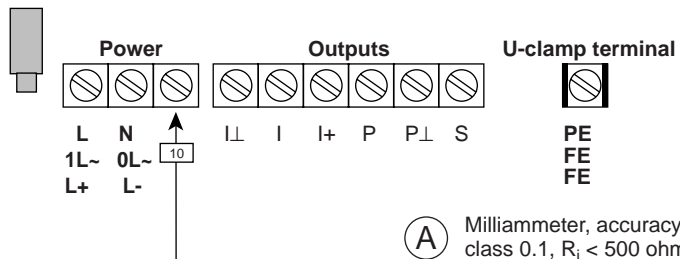

Connection of milliammeter and electronic frequency counter, see Sect. 2.3 "Connection of outputs".

- (A)** Milliammeter, accuracy class 0.1, $R_i < 500$ ohms, range 4-20 mA
Electronic frequency counter, input resistance approx. 1 kohm, range 0-1 kHz, time base min. 1 second, see connection diagrams in Sect. 2.3.2.

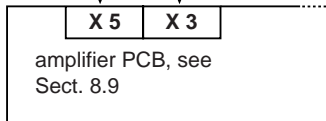

- a) Switch off power source before opening the housing !
- b) Unscrew the 4 recessed head screws, see Fig. A in Sect. 8.5, and remove transparent cover from the signal converter housing.
- c) Unscrew recessed head screw, see Fig. B in Sect. 8.5, and remove black plastic cover.
- d) Pull off blue 7-pin plug from the amplifier PCB, see Sect. 8.9: socket **X3** field power supply and socket **X5** signal cables.
- e) Connect plug **B** to socket **X3** (2-pin) and plug **C** (5-pin) to socket **X5** (3-pin) by way of adapter **A** (5-to-3pin).

Warning: Instrument must be properly grounded to avoid personnel shock hazard.

Check of setpoint display

- 1) Switch on power source, allow at least 15 minutes' warm-up time.
- 2) Set switch **D** (front panel of GS 8A) to "0" position.
- 3) Adjust zero to 0 or 4 mA with the 10-turn potentiometer **P** (front panel of GS 8A), depending on setting in Fct. 1.05, deviation $\leq \pm 10 \mu\text{A}$.
- 4) Calculate position of switch **Y** and displayed setpoints "**I**" and "**f**":

$$4.1) X = \frac{Q_{100\%} \times K}{GK \times DN^2}$$

$Q_{100\%}$ full-scale range (100%) in volumetric unit **V** per unit time **t**
GK primary constant, see instrument nameplate
DN meter size DN in mm, not inches, see instrument nameplate
t time in seconds (**Sec**), minutes (**min**) or hours (**hr**)
V volumetric unit
K constant, according to following table

V \ t	Sec	min	hr
Liter	25 464	424.4	7.074
m ³	25 464 800	424 413	7 074
US gallons	96 396	1 607	26.78

Note:

Sticker on the GS 8A primary head simulator still gives values for "inch" flowmeter. **Do not use any more !**

- 4.2) Determine position of switch Y: Use table (front panel GS 8A) to determine value **Y** which comes closest to factor **X** and meets condition $Y \leq X$.
- 4.3) Calculate setpoint reading "I" for current output: $I = I_{0\%} + \frac{Y}{X} (I_{100\%} - I_{0\%})$ in mA
 $I_{0\%}$ current (0/4mA) at 0% flowrate
 $I_{100\%}$ current (20mA) at 100% flowrate
- 4.4) Calculate setpoint reading "f" for pulse output: $f = \frac{Y}{X} \times P_{100\%}$ in Hz
 $P_{100\%}$ pulses per second (Hz) at 100% flowrate
- 5) Set switch **D** (front panel GS 8A) to position "+" or "-" (forward/reverse flow).
- 6) Set switch **Y** (front panel GS 8A) to the value determined by the method described above.
- 7) Check setpoint readings **I** and **f**, see points 4.3 and 4.4 above.
- 8) Deviation $< 1.5\%$ of setpoint. If greater, replace signal converter, see Sect. 8.4.
- 9) Test of linearity: set lower **Y** values, readings will drop in proportion to the calculated **Y** values.
- 10) **Switch off power source** after completing the test.
- 11) Disconnect the GS 8A.
- 12) Reassemble in reverse order, see points e) – b) under "electrical connection", see illustration in Sect. 8.5.
- 13) The system is ready for operation after the power source has been switched on.

Example: see overleaf

Example

Full-scale range	$Q_{100\%}$	= 200 m ³ /hr (Fct. 1.01)
Meter size	DN	= 80 mm = 3" (Fct. 3.02)
Current at $Q_{0\%}$	$I_{0\%}$	= 4 mA
	$I_{100\%}$	= 20 mA
		} (Fct. 1.05)
Pulses at $Q_{100\%}$	$P_{100\%}$	= 280 pulses/hr (Fct. 1.06)
Primary head constant	GKL	= 3.571 (see nameplate)
Constant (V in m ³)		
(t in hr)	K	= 7074 (see Table)
(DN in mm)		

Calculation of "**X**" and position of "**Y**"

$$X = \frac{Q_{100\%} \times K}{GKL \times DN^2} = \frac{200 \times 7074}{3.571 \times 80 \times 80} = 61.905$$

Y = 80, position of switch Y, see front panel GS 8A
(comes closest to X value and is smaller than X).

Calculation of setpoint readings **I** and **f**

$$I = I_{0\%} + \frac{Y}{X} (I_{100\%} - I_{0\%}) = 4 \text{ mA} + \frac{40}{61.905} (20\text{mA} - 4\text{mA}) = 14.3 \text{ mA}$$

Deviations are permissible between 14.1 and 14.6 mA (equivalent to $\pm 1.5\%$).

$$f = \frac{Y}{X} \times P_{100\%} = \frac{40}{61.905} \times \text{pulses / hr} = 129.2 \text{ pulses/hr}$$

Deviations are permissible between 127.3 and 131.1 pulses/hr (equivalent to $\pm 1.5\%$).

**If you need to return your flowmeter to Krohne,
please refer to last but one page of these Instructions !**

Cleaning the signal converter housing 8.1

Switch off power source before cleaning !

The housing of the signal converter (material: polycarbonate, PC) may only be cleaned with a solventless detergent !

Replacement of power fuse(s) 8.2

A) Fuse F1 in AC Versions 1, 2 and 3**Switch off power source before opening the housing !**

Refer to Sect. 8.5 for Figs. A and B.

- 1) Unscrew the 4 recessed head screws (**Fig. A**), and remove transparent cover from signal converter housing.
- 2) Unscrew the recessed head screw (**Fig. B**) and remove the black plastic cover.
- 3) Take out old and insert new power fuse F1, on the left next to the green connecting terminals. Please refer to the following table for fuse rating and order number.
- 4) Reassemble in reverse order, points 2) – 1) above..

B) Fuse F1 and F2 for the DC Version**Switch off power source before opening the housing !**

Refer to Sect. 8.5 for Figs. A to F.

- 1) Unscrew the 4 recessed head screws (**Fig. A**), and remove transparent cover.
- 2) Unscrew the recessed head screw (**Fig. B**) and remove the black plastic cover.
- 3) Carefully pull out the green connecting plugs (supply power and outputs) (**Fig. C**).
- 4) Unscrew the 2 recessed head screws (**Fig. D**) and remove the black metal cover.
- 5) Carefully pull out the blue 9-pin plug (connection to the primary head) (**Fig. D**).
- 6) With a screwdriver, carefully remove the 4 metal clips (**Fig. E**).
- 7) Remove the electronics unit from the housing (**Fig. F**) and detach the ground conductor.
- 8) Replace power fuses F1 and F2 on the power supply PCB, refer to Sect. 8.9 for illustration of the PCB. Refer to the following table for fuse rating and order number.
- 10) Reassemble in reverse order, points 7) - 1) above.

Power PCB	Supply power	Fuse F1 (and F2)		Location and position of voltage selector	
		Rating	Order No.		
1. AC version	230/240 V AC	125 mA T	5.06627		
	115/117 V AC	200 mA T	5.05678		
2. AC version	200 V AC	125 mA T	5.06627		
	100 V AC	200 mA T	5.05678		
3. AC version	48 V AC	400 mA T	5.05892		
	24 V AC	800 mA T	5.08085		
DC version	11-32 V DC	F1 + F2 1.25 A T	5.09080		

Warning: Instrument must be properly grounded to avoid personnel shock hazard.

8.3 Changeover of operating voltage on AC Versions 1, 2 and 3 (not DC Version)

Switch off power source before opening the housing !

Refer to Sect. 8.5 for Figs. A-F.

- 1) Unscrew the 4 recessed head screws (**Fig. A**), and remove transparent cover.
- 2) Unscrew the recessed head screw (**Fig. B**) and remove the black plastic cover.
- 3) Carefully pull out the green connecting plugs (supply power and outputs) (**Fig. C**).
- 4) Unscrew the 2 recessed head screws (**Fig. D**) and remove the black metal cover.
- 5) Carefully pull out the blue 9-pin plug (connection to the primary head) (**Fig. D**).
- 6) With a screwdriver, carefully remove the 4 metal clips (**Fig. E**).
- 7) Remove the electronics unit from the housing (**Fig. F**) and detach the ground conductor.
- 8) Transpose voltage selector on the power supply PCB (illustration in Sect. 8.9) to obtain the required voltage according to the table in Sect. 8.2.
- 9) Change power fuse F1, see table for fuse ratings.
- 10) Reassemble in reverse order, points 7) - 1) above.

8.4 Replacement of electronics unit of signal converter

Switch off power source before opening the housing !

Refer to Sect. 8.5 for Figs. A-G.

- 1) Unscrew the 4 recessed head screws (**Fig. A**), and remove transparent cover.
- 2) Unscrew the recessed head screw (**Fig. B**) and remove the black plastic cover.
- 3) Carefully pull out the green connecting plugs (power supply and outputs) (**Fig. C**).
- 4) Unscrew the 2 recessed head screws (**Fig. D**) and remove the black metal cover.
- 5) Carefully pull out the blue 9-pin plug (connection to the primary head) (**Fig. D**).
- 6) With a screwdriver, carefully remove the 4 metal clips (**Fig. E**).
- 7) Carefully remove the electronics unit from the housing (**Fig. F**) and detach the ground conductor.
- 8) Carefully transpose the DATAPROM (IC 13) on the amplifier PCB (illustration in Sect. 8.9) from the "old" to the "new" electronics unit (**Fig. G**). When inserting, note the direction of the IC 13, see Sect. 8.9 "illustration of the PCBs".
- 9) Check supply power and fuse F1 for the new electronics unit, and if necessary change over or replace as described in Sect. 8.3, points 8) and 9).
- 10) Reassemble in reverse order, points 7) - 1) above.

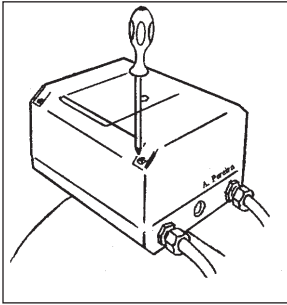

Fig. A

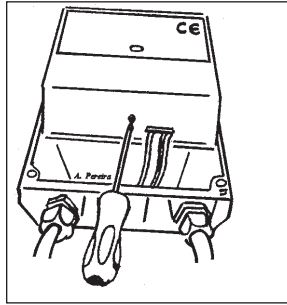

Fig. D

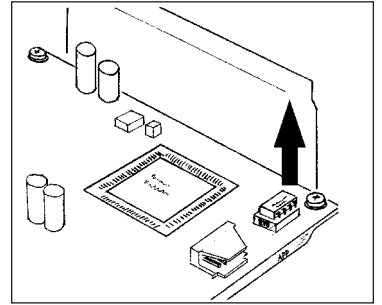

Fig. G

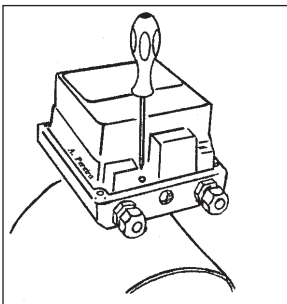

Fig. B

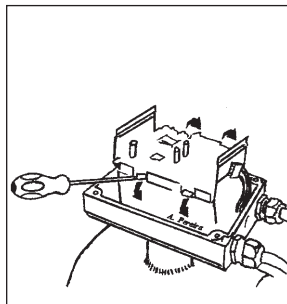

Fig. E

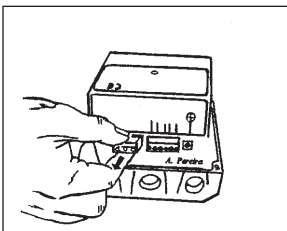

Fig. C

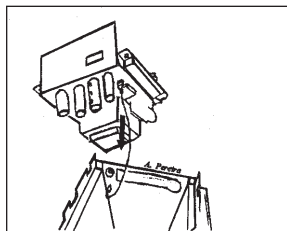

Fig. F

8.6 Turning the display PCB

Switch off power source before opening the housing !

Figs. A, B and D are given in Sect. 8.5.

- 1) Unscrew the 4 recessed head screws (**Fig. A**) and remove the transparent cover.
- 2) Unscrew the recessed head screw (**Fig. B**) and remove the black plastic cover.
- 3) Unscrew the 2 recessed head screws (**Fig. D**) and remove the black metal cover.
- 4) Unscrew the 4 recessed head screws on the display PCB.
- 5) Turn display PCB carefully.
- 6) Fold the ribbon cable as shown in the diagrams in Sect. 8.8
PLEASE NOTE: The ribbon cable must lie flat between the display and amplifier PCBs and must not exert any pressure on electronic components.
- 7) Reassemble in reverse order, points 4) - 1) above.

8.7 Retrofitting the display unit

Switch off power source before opening the housing !

Figs. A, B and D are given in Sect. 8.5.

- 1) Unscrew the 4 recessed head screws (**Fig. A**) and remove the transparent cover.
- 2) Unscrew the recessed head screw (**Fig. B**) and remove the black plastic cover.
- 3) Unscrew the 2 recessed head screws (**Fig. D**) and remove the black metal cover.
- 4) Insert the foil connector of the display unit into jack **X7** on the amplifier PCB, see diagram in Sect. 8.9. Ensure contact side is correctly positioned..
- 5) **Carefully** turn display in the desired direction.
Fold the ribbon cable as shown in the diagrams in Sect. 8.8
PLEASE NOTE: The ribbon cable must lie flat between the display and amplifier PCBs and must not exert any pressure on electronic components.
- 6) Reassemble in reverse order, see points 3) - 2) above.
- 7) Switch on power source.
- 8) For operator control and display of measured values, refer to Sect. 4 and 5.
- 9) Replace transparent cover and tighten down the 4 recessed head screws (**Fig. A**).

Socket X7 locked

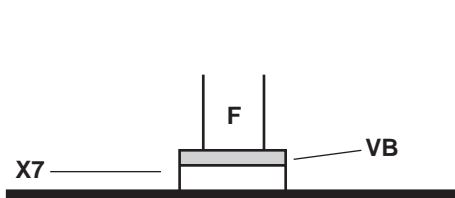

Socket X7 unlocked

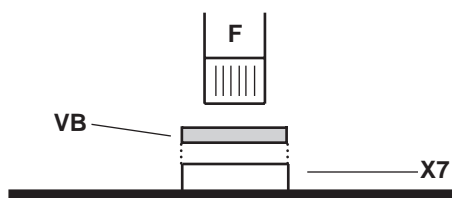

amplifier PCB

- F Ribbon cable
- VB Locking clip X7
- X7 Socket on amplifier PCB

- A Socket X7 on amplifier PCB, see Sect. 8.9
- B Socket on display PCB
- C Contact side
- D Display
- F Ribbon cable
- I Insulated side
- K 5 keys for operator control
- R Reference point, power terminals
- 90° Bend cables 90° as shown in drawing

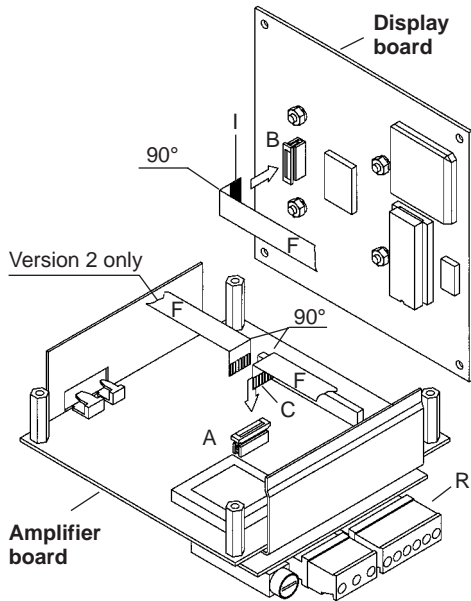

Version 2

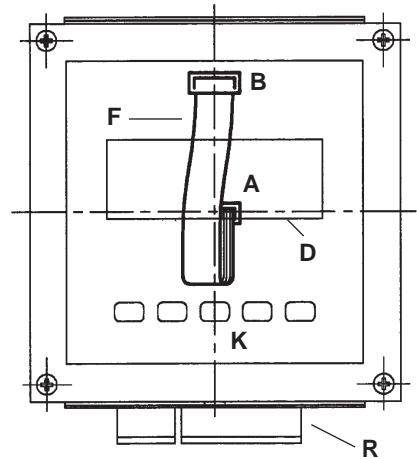

Version 3/ Standard IFC 010 F/D
Separate version

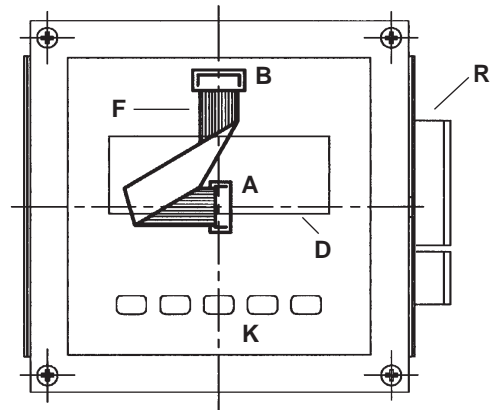

Version 1 / Standard IFC 010 K/D
Compact flowmeter

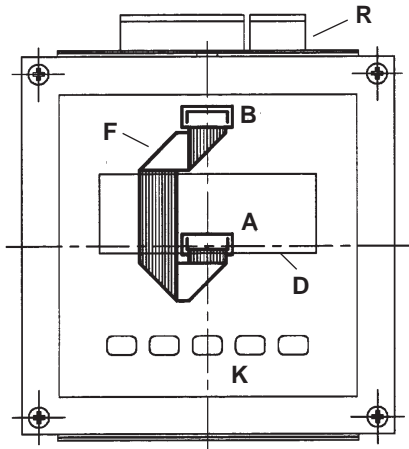

Version 4

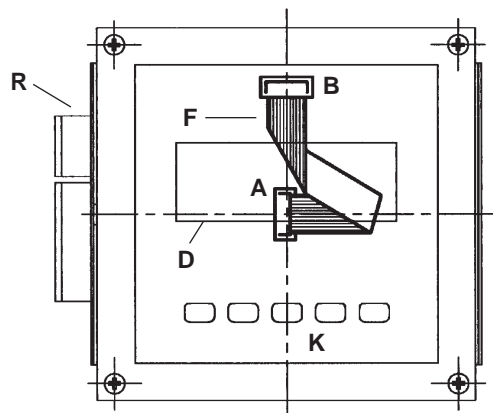

8.9 Illustrations of the PCBs

A) Amplifier PCB

IC 13	DATAPROM (sensor), see Sect. 8.4
MP1, MP5	Measuring points, see Sect. 7.6
S3, S6	for "empty tube" cut-out, see Sect. 6.2
TP1	Test point, see Sect. 7.6
X1	20-pin socket connector, see Sect. 7.6 and 7.7
X3	2-pin plug connector, pin 7 and 8, field power supply, see Sect. 7.5 and 7.7
X4	IMoCom Bus, plug connector for connection of RS 232 adapter, see Sect. 6.1
X5	5-pin plug connector, pin 1-5, signal cable, see Sect. 7.5 and 7.7
X7	10-pin socket (A) for foil connector (display unit), see Sect. 8.6 and 8.7.

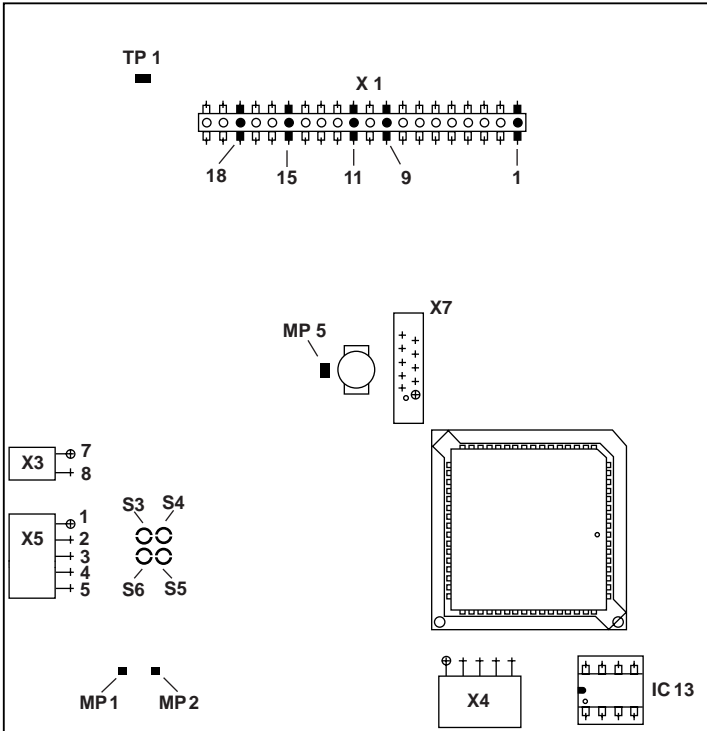

Solder points S3 and S6



B) Power supply PCB, AC Versions 1, 2 and 3

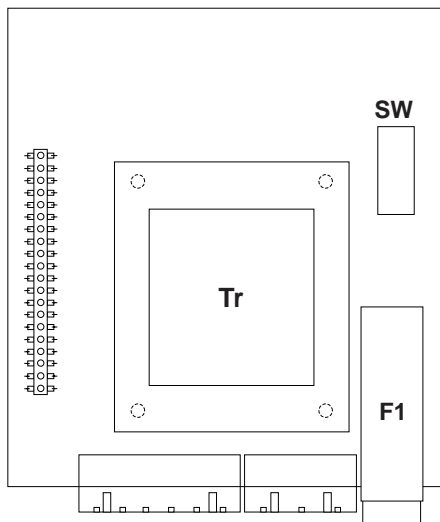

- F1** Power fuse, see Sect. 8.2 or 9 for ratings
SW Voltage selector, see Sect. 8.3 for voltage changeover
Tr Transformer

C) Power supply PCB, DC Version

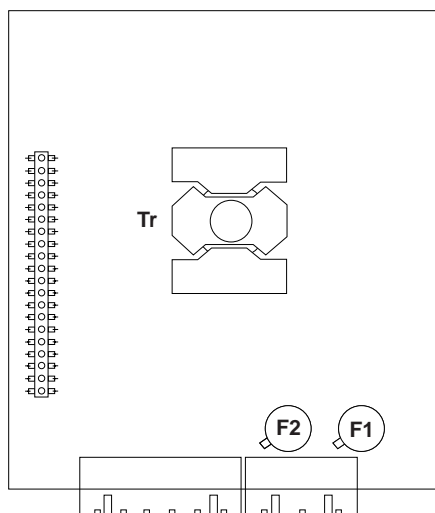

- F1, F2** Power fuses, see Sect. 8.2 or 9 for ratings
Tr Transformer

9 Order numbers

Electronic unit

Power supply unit	Supply power	Order No.	
		IFC 010 D with display	IFC 010 B without display
AC Version 1	230 / 240 V AC	2.07494.10	2.07494.00
	115 / 117 V AC	2.07494.15	2.07494.05
AC Version 2	200 V AC	2.07494.12	2.07494.02
	100 V AC	2.07494.14	2.07494.04
AC Version 3	48 V AC	2.07494.34	2.07494.24
	24 V AC	2.07494.58	2.07494.48
DC-Version	24 V DC (11-32 V DC)	2.07527.10	2.07527.00

Power fuse F1 for AC and F1 and F2 for DC

Supply power	Rating	Order No.	Fuse type
200 and 230 / 240 V AC	125 mA T	5.06627	5 x 20 G-fuse switching capacity 1500 A
100 and 115 / 117 V AC	200 mA T	5.05678	
48 V AC	400 mA T	5.05892	
24 V AC	800 mA T	5.08085	
11-32 V DC	1.25 A T	5.09080	TR 5, switching capacity 35 A

Display unit, retrofit kit for basic version IFC 010 – / B
incl. transparent cover and connecting cable:

Order No. 1.30915.92

RS 232 adapter incl. English CONFIG operator software,
for operator control of signal converter via MS-DOS PC or laptop:

Order No. 2.10531.01

HHT hand held terminal for operator control of signal converter

Order No. 2.10591.01

Part D Technical data, measuring principle and block diagram

10 Technical data

10.1 Full-scale range $Q_{100\%}$

Full-scale ranges $Q_{100\%}$

Flow rate $Q = 100\%$ 6 liter/h to 33 900 m³/h (0.03 - 156 000 US Gal/min), adjustable as required, equivalent flow velocity 0.3 - 12 m/s (1 - 40 ft/s)

Unit m³/hr, Liter/Sec, US gallons/min. or user-defined unit, e.g. Liter/day or US MGal/day

Flow tables

v = flow velocity in m/s

Meter size		Full-scale range $Q_{100\%}$ in m ³ /h		
DN		$v = 0.3$ m/s	$v = 1$ m/s	$v = 12$ m/s
mm	inch	(minimum)		(maximum)
2.5	1/10	0.0053	0.0177	0.2121
4	1/8	0.0136	0.4520	0.5429
6	1/4	0.0306	0.1018	1.222
10	3/8	0.0849	0.2827	3.392
15	1/2	0.1909	0.6362	7.634
20	3/4	0.3393	1.131	13.57
25	1	0.5302	1.767	21.20
32	-	0.8686	2.895	34.74
40	1 1/2	1.358	4.524	54.28
50	2	2.121	7.069	84.82
65	-	3.584	11.95	143.3
80	3	5.429	18.10	217.1
100	4	8.483	28.27	339.2
125	-	13.26	44.18	530.1
150	6	19.09	63.62	763.4
200	8	33.93	113.1	1357
250	10	53.02	176.7	2120
300	12	76.35	254.5	3053
400	16	135.8	452.4	5428
500	20	212.1	706.9	8482
600	24	305.4	1018	12215
700	28	415.6	1385	16625
800	32	542.9	1810	21714
900	36	662.8	2290	26510
1000	40	848.2	2827	33929

v = flow velocity in ft/s

Meter size		$Q_{100\%}$ in US Gal/min	
DN		$v = 1$ ft/s	$v = 40$ ft/s
mm	inch	(minimum)	(maximum)
2.5	1/10	0.0245	0.979
4	1/8	0.0383	1.530
6	1/4	0.1530	6.120
10	3/8	0.3735	14.93
15	1/2	0.8405	33.61
20	3/4	1.494	59.75
25	1	2.334	93.34
32	1 1/4	3.824	153.0
40	1 1/2	5.979	239.0
50	2	9.339	373.5
65	2 1/2	15.78	630.9
80	3	23.90	955.6
100	4	37.35	1493
125	5	58.38	2334
150	6	84.05	3361
200	8	149.43	5975
250	10	233.4	9334
300	12	336.2	13442
400	16	597.9	23899
500	20	933.9	37345
600	24	1345	53781
700	28	1919	76760
800	32	2507	100272
900	36	3173	126904
1000	40	3917	156672

Pulse output

$\pm F$ Error in % of flowrate (actual value):

Curve A: DN 10 – 600 / $\frac{3}{8}$ " - 24"

$v \geq 0.4$ m/s or $v \geq 1.3$ ft/s : ± 0.5 % of measured value
 $v \geq 0.4$ m/s or $v \geq 1.3$ ft/s : ± 0.002 m/s or 0.0066 ft/s

Curve B: DN 700 – 1000 / 28" – 40"

$v \geq 0.25$ m/s or $v \geq 0.8$ ft/s : ± 0.8 % of measured value
 $v \geq 0.25$ m/s or $v \geq 0.8$ ft/s : ± 0.002 m/s or 0.0066 ft/s

Q Actual flowrate

Q_F Flow for error limit $v_F = 0.25$ or 0.8 ft/s (see Flow tables)

v Flow velocity in m/s and ft/s

v_F Flow velocity in m/s and ft/s at Q_F (see Flow tables)

Reference conditions

Product	Water, 10 to 30°C / 50 to 86°F
Electrical conductivity	> 300 μ S/cm (μ mho/cm)
Power supply (line voltage)	U _N (± 2 %)
Ambient temperature	20 to 22°C / 68 to 71.6°F
Warm-up time	30 minutes
Straight inlet run	> 10 x DN
Straight outlet run	> 3 x DN
Primary heads	properly grounded and centered

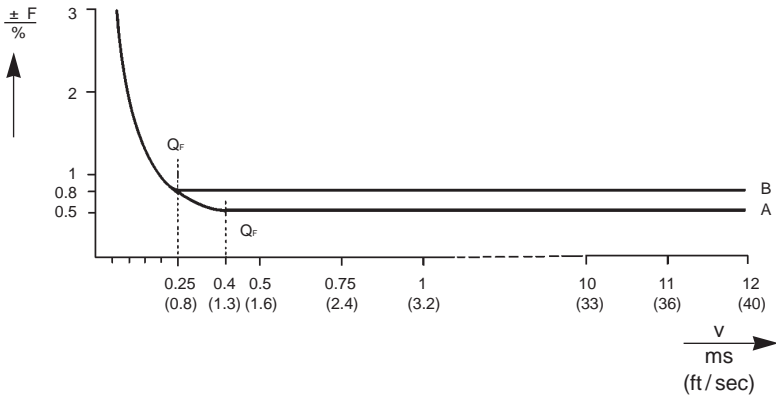

Current output

same as above error limit for pulse output **plus ...**

0 to 20 mA: } ± 0.05 % } of full-scale range in each case
 4 to 20 mA: } ± 0.062 % }

10.3 IFC 010 Signal converter

Versions

B - version

D - version

Add-on equipment (option)

without display / control unit (basic version)

with display / control unit

- CONFIG software and RS 232 adapter for control via MS-DOS-PC, connection to IMoCom interface
- Hand-Held-Terminal for control of basic versions
- Other bus and computer interfaces on request

Current output

Function

Current

Active output

Passive output

- all operating data settable, galvanically isolated

0 - 20 mA and 4 - 20 mA

load max. 500 ohms

external voltage:	15 ... 20 V DC	20 ... 32 V DC
-------------------	----------------	----------------

load: min. ... max.	0 ... 500 Ω	250 ... 750 Ω
---------------------	-------------	---------------

Error identification

0 / 3.6 / 22 mA

Forward/reverse measurement

direction identified via status output

Pulse output

Function

- all operating data settable
- galvanically isolated
- digital pulse division, interpulse period non-uniform, therefore if frequency meters connected allow for minimum counting interval:

$$\text{gate time, totalizer} \geq \frac{1000}{P_{100\%} [\text{Hz}]}$$

Pulse rate for Q = 100 %

10, 100 or 1000 pulses per second (= Hz), fixed or optionally adjustable in pulses per liter, m³ or US gallons (special version: up to 10 kHz scaling)

Active output:

connection: electronic totalizer (EC)

internal voltage: approx. 15 V DC, from current output

load rating: $I_{\text{max}} < 23 \text{ mA}$ when operated without current output

$I_{\text{max}} < 3 \text{ mA}$ when operated with current output

Passive output:

connection electromechanical (EMC) or electronic (EC) totalizers

external voltage: $U_{\text{ext}} \leq 30 \text{ V DC} / \leq 24 \text{ V AC}$

load current: $I_{\text{max}} \leq 150 \text{ mA}$

Pulse width

50, 100, 200, 500 ms or 1 s, selectable with frequencies below 10 Hz

Forward/reverse measurement

direction identified via status output

Status output (passive)

Function

settable as indicator for flow direction, errors or trip point

Connection

external voltage: $U_{\text{ext}} \leq 30 \text{ V DC} / \leq 24 \text{ V AC}$

load current: $I_{\text{max}} \leq 150 \text{ mA}$

Time constant

0.2 to 99.9 seconds, settable in increments of 0.1 second

Low-flow cutoff

cutoff "on" value: 1 to 19 % } of $Q_{100\%}$, adjustable in
cutoff "off" value: 2 to 20 % } 1 % increments

Local display (D versions only)

Display functions

3-line LCD

actual flowrate, forward, reverse and sum totalizers (7-digit) or 25-character bar graph with percent display and status messages

Display units: actual flowrate

settable in liter/s, m³/h, US gallons/min or user-defined unit, e.g. hectoliter/day or US million gallons/day

totalizers

liter, m³ or US gallons and 1 user-defined unit

(e.g. hectoliter), selectable overflow time

Language of plain texts

English, German, French, others on request

Display: 1st (top) line

8-character, 7-segment numeral and sign display, symbols for key acknowledgement

2nd (middle) line

10-character, 14-segment text display

3rd (bottom) line

6 markers ▼ to identify display

Power supply	1. AC-Version Standard	2. AC-Version Option	3. AC-Version Option	DC-Version Option
1. Rated voltage tolerance band	230 / 240 V 200 – 260 V	200 V 170 – 220 V	48 V 41 – 53 V	24 V 11 – 32 V
2. Rated voltage tolerance band	115 / 120 V 100 – 130 V	100 V 85 – 110 V	24 V 20 – 26 V	– –
Frequency	48 – 63 Hz			–
Power consumption (incl. primary head)	approx. 5 VA			approx. 4.5 W
When connected to a functional extra-low voltage, 11-32 V DC, protective separation (PELV) must be ensured (VDE 0100/VDE 0106 and IEC 364/IEC 536)				

Housing	
Material	polycarbonate (PC)
Protection category (IEC 529/EN 60 529)	IP 67, equivalent to NEMA 6, same as primary head
IFC 010 K (compact)	IP 65, equivalent to NEMA 4 / 4X
IFC 010 F (separate)	

IFC 010 F and ZD dimensions and weights 10.4

IFC 010 F
weight approx. 3.8 kg / 8.4 lb

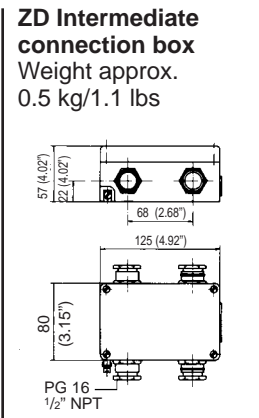
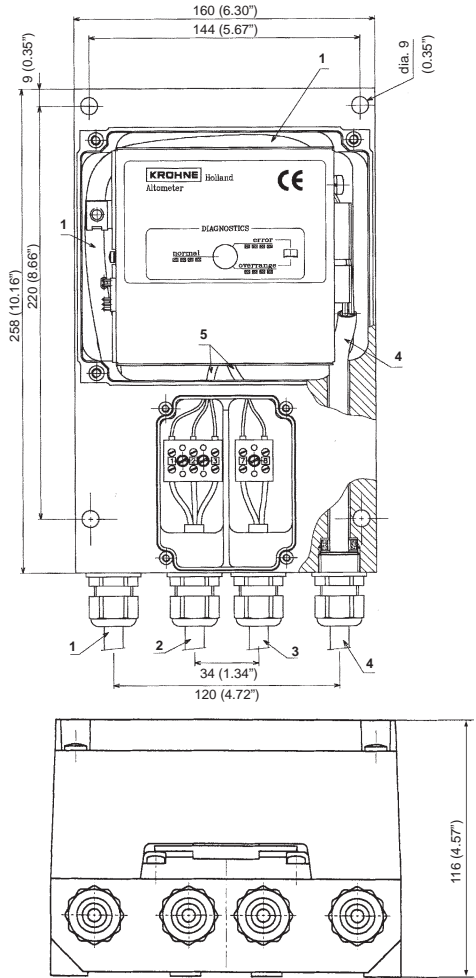

- 1 output cable (see Sect. 2.3)
- 2 signal cable of primary head (see Sect. 1.3)
- 3 field power cable of primary head (see Sect. 1.3)
- 4 power supply cable (see Sect. 1.2)
- 5 internal connection (see Fig. in Sect. 8.9, plug connectors X3 and X5)

dimensions in mm

10.5 Instrument nameplates

Separate signal converter in rotatable field housing

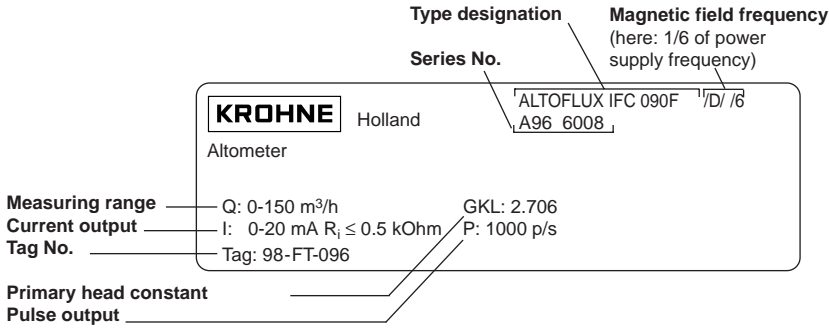

Compact flowmeters

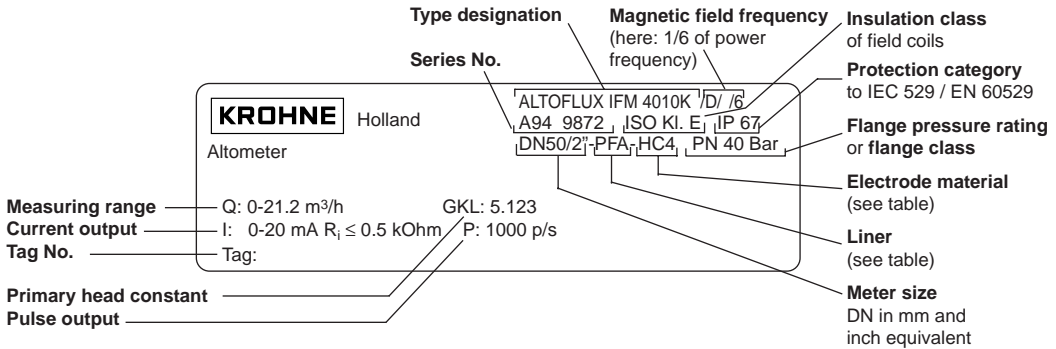

Abbreviations

Liner

AL	Fused aluminium oxide (99.7% Al ₂ O ₃)
H	Hard rubber
NE	Neoprene
PFA	Teflon®-PFA
PP	Polypropylene
PUI	Irethane
T	Teflon®-PTFE
W	Soft rubber

Electrode material

C	Conductive rubber compound
HB 2	Hastelloy B2
HC 4	Hastelloy C4
IN	Incoloy
M4	Monel 400
Ni	Nickel
PT	Platinum
TA	Tantalum
TI	Titanium
V4A	Stainless steel 1.4571 (SS 316 Ti)
xx / TC	xx with conductive PTFE compound (xx = base material, e.g. HC4)

Teflon® is a registered trademark of Du Pont

The flowmeter is designed for electrically conductive fluids.

Measurement is based on Faraday's law of induction, according to which a voltage is induced in an electrically conductive body which passes through a magnetic field. The following expression is applicable to the voltage.:

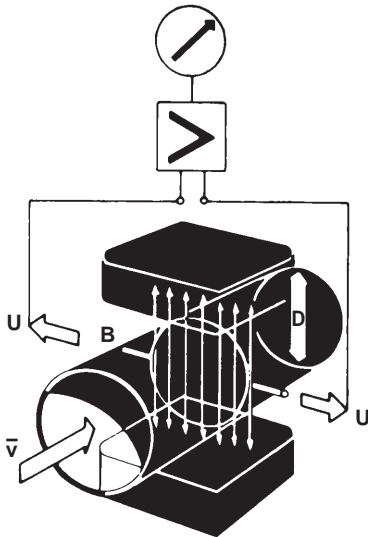

$$U = K \times B \times \bar{v} \times D$$

where:

U = induced voltage

K = an instrument constant

B = magnetic field strength

\bar{v} = mean velocity

D = pipe diameter

Thus the induced voltage is proportional to the mean flow velocity, when the field strength is constant.

Inside the electromagnetic flowmeter, the fluid passes through a magnetic field applied perpendicular to the direction of flow. An electric voltage is induced by the movement of the fluid (which must have a minimum electrical conductivity). This is proportional to the mean flow velocity and thus to the volume of flow. The induced voltage signal is picked up by two electrodes which are in conductive contact with the fluid and transmitted to a signal converter for a standardized output signal.

This method of measurement offers the following advantages:

1. No pressure loss through pipe constriction or protruding parts.
2. Since the magnetic field passes through the entire flow area, the signal represents a mean value over the pipe cross-section; therefore, only relatively short straight inlet pipes $5 \times DN$ from the electrode axis are required upstream of the primary head.
3. Only the tube liner and the electrodes are in contact with the fluid.
4. Already the original signal produced is an electrical voltage which is an exact linear function of the mean flow velocity.
5. Measurement is independent of the flow profile and other properties of the fluid.

The magnetic field of the primary head is generated by a square wave current fed from the signal converter to the field coils.

This field current alternates between positive and negative values. Alternate positive and negative flowrate-proportional signal voltages are generated at the same frequency by the effect of the magnetic field, which is proportional to the current. The positive and negative voltages at the primary head electrodes are subtracted from one another in the signal converter. Subtraction always takes place when the field current has reached its stationary value, so that constant interference voltages or external or fault voltages changing slowly in relation to the measuring cycle are suppressed. Power line interference voltages coupled in the primary head or in the connecting cables are similarly suppressed.

12 Block diagram – signal converter

1 Input amplifier

- overdrive-proof signal processing, rapid and accurate
- digital signal processing and sequence control
- patented, high-resolution A/D converter, digitally controlled and monitored
- high signal-to-noise ratio through low-loss field power supply

2 Field power supply

- the low-loss field power supply generates the pulsed, electronically controlled DC current for the magnetic coils of the primary head

3 Current output

- galvanically isolated from all other groups
- converts the digital output signal from the μP 3 microprocessor into a proportional current

4 Binary outputs

- galvanically isolated from other groups
- selectable input/output combinations
- pulse output (P), passive FET optocouplers allow connection of electronic and electromechanical totalizers of electronic and electromechanical totalizers
- status output (S), for limit value, error identification, or flow direction in forward/reverse flow mode (F/R)

5 Display/operator control unit (option, D Version)

- large-size illuminated LC display
- 3 keys for operator control of the signal converter
- connection to the internal IMoCom bus
- unit can be retrofitted to basic devices (B Version)

6 IMoCom bus plug connector

for connection of external control and test devices such as:

- HHT handheld terminal (option), display/operator control unit for operation of basic versions
- adapter and CONFIG software for operation via MS-DOS PC

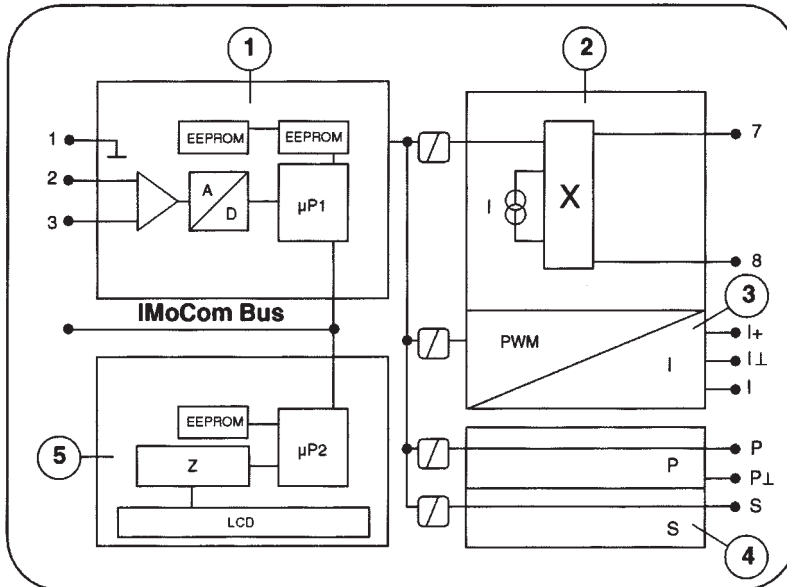

Keyword	Section No.	Fct. No.
A		
Abbreviations	1.3.2, 1.3.4, 2.1, 4.4	
Accuracies	10.2	
ADC = analog-digital converter	4.5, 12	
Ambient temperature	10.3	
Application	5.15	3.06
B		
Block diagram IFC 010	12	
B version (basic)	4, 6.1	
C		
Cable length	1.3.4	
Changeover, power supply	8.3	
Characteristics of outputs	5.14	
Clearing error messages	4.6	
Coding for entry into setting level	5.10	3.04
CONFIG software	6.1	
Connecting & operating points		
– front panel	4.2	
– PCB power supply	8.9	
– PCB signal converter	8.9	
Connection diagrams		
– GS8A simulator	7.7	
– Outputs	2.3	
– Power supply	1.2	
– primary head/signal converter	1.3.5	
Conversion factor		
– Quantity (volume)	4.4 + 5.12	3.05
– Time	4.4 + 5.12	3.05
Current output I	2.2, 2.3, 5.6	1.05
D		
Data	4.4	
Data column	4.1-4-3	
Data errors	4.5	
Dimensions		
– IFC 010 F	10.4	
– ZD	10.4	
Display	4.2, 5.4, 8.7	1.04
DN = meter size in mm	4.4	3.02
DS, signal cable A	1.3.1 et seq.	
E		
EC = electronic totalizer	2.3, 5.8	1.06
Electrical connection		
– GS8A simulator	7.7	
– outputs	2.3	
– power supply	1.2	
Electromagnetic compatibility	page 0/4	
EMC = electromechanical totalizer	2.3, 2.6, 5.8	1.06
EN technical standards	page 0/4	
Error	4.5	
Error list	4.5	
Error (messages)	4.5	
– cancel	4.5	
– limits	10.2	
– reset / delete	4.6	
External totalizers	2.2, 2.3, 5.7	1.06

Keyword	Section No.	Fct. No.
F		
F = forward flow	4.4, 5.3	1.04-1.07
Factory settings	3.2	
Fatal error	4.5	
FE = functional ground	1.2, 1.3.2	
Field power supply	5.11, 10.3, 12	3.02
Flow direction	4.4, 5.1, 5.13	3.02
Flow rate (Q)	4.4, 5.1	3.02
Flow velocity v	4.4, 5.1	3.02
Frequency (pulse output)	2.2, 2.3, 5.7	1.06
Frequency output, see pulse output P	2.2, 2.3, 5.7	1.06
Full-scale range Q _{100%}	4.4, 5.1	1.01, 3.02
Function(s)	4.4	
Function of keys	4.1-4.3	
Functional checks	7.1 et seq.	
– hardware info	7.3	2.0.2
– primary head	7.5	
– setpoint display values	7.7	
– signal converter	7.6, 7.7	
– system	7.4	
– test full scale range	7.2	2.01
– zero	7.1	3.03
Functional ground FE	1.2, 1.3.2	
Functions column	4.1	
Fuses (F . . .)	8.2, 8.3	
G		
GKL = primary (head) constant	4.4, 5.10	3.02
Grounding primary head	1.3.2	
GS 8A = primary (head) simulator	7.7	
H		
Hand held terminal	6.1	
Hardware information	7.3	2.02
I		
I = current (analog) output	2.2, 2.3, 5.6	1.05
IEC technical standards	page 0/4	
IMoCom bus (plug)	6.1, 8.9, 12	
Initial start-up	3	
Input (programming)	4.1 et seq.	
Instrument nameplates	10.5	
Interface RS 232	6.1, 10.3	
Intermediate connection box (ZD)	1.3.5, 10.4	
Internal electronic totalizer	2.4, 5.5, 5.7	1.04
K		
Keys	4.1-4.3	
Keystroke combinations for		
– entry into setting level	4.1-4.3	3.04
– error cancellation	4.6	
– quitting setting level	4.1-4.3	
– totalizer reset	4.6	
L		
Language of display texts	5.10	3.01
LCD display, see display	4.2, 4.4, 5.4	1.04
Limit message	4.4, 5.8	1.07
Line voltage, see power supply		
Low-flow cutoff (SMU)	4.4, 5.3	1.03

Keyword	Section No.	Fct. No.
M		
Magnetic field frequency	4.4 + 5.11	3.02
Main menu column	4.1	
Main menus	4.1 to 4.3	1.00, 2.00, 3.00
Mass flow measurement, see user defined unit	4.4, 5.12	
Measuring principle	11	
Menu	4.1, 4.4	
Meter size (DN)	4.4	3.02
N		
Numerical format, display	5.4, 5.5	1.04
O		
Option = optional equipment	6.1, 10.3	
Order numbers	9	
Outputs		
– characteristics	5.14	
– connection diagrams	2.3	
– setting	4.4	
– I	5.6	1.05
– P	5.7	1.06, 3.07
– S	5.8	1.06, 1.07, 3.07
– voltage stable when measuring tube empty	6.2	
Overflow, display	5.5	1.04
Overranged		
– I (current output)	2.1, 2.3, 5.6, 5.8	1.06, 1.07
– P (pulse output)	2.2, 2.3, 5.7, 5.8	1.06, 1.07
Overvoltage class	1.2	
P		
P = pulse output	2.2, 2.3, 4.4, 5.7	1.06
PCB = printed circuit boards	8.9	
PC software	6.1	
PE = protective conductor	1.2	
Power supply (= line voltage)		
– changeover	8.3	
– connection	1.2, 10.3	
– consumption	10.3	
– failure	4.5, 7.4	
– frequency	1.2, 10.3	
– voltage	1.2, 10.3	
Primary constant, see GKL	4.4, 5.10	3.02
Primary head		
– constant, see GKL	4.4, 5.11	3.02
– simulator GS 8A	7.7	
– testing	7.5	
Primary simulator, see GS 8A	7.7	
Printed circuit boards, see PCB	8.9	
Program organization	4.1	
Programming = input	4.1-4.3	
Programming mode, entry into	4.1-4.3	
Protective conductor PE	1.2	
Pulse output P	4.4, 5.7	1.06
Pulse width	4.4, 5.7	1.06
Pulses per unit time	4.4, 5.7	1.06
Pulses per unit volume	4.4, 5.7	1.06
Q		
Q = flow rate	4.4, 5.1	1.01, 3.02
Q _{100%} = full-scale range	4.4, 5.1	1.01, 3.02
R		
R = reverse flow	4.4, 5.13	1.04-1.07
Range setting	4.4, 5.1	1.01, 3.02
Replacement		
– electronic unit	8.4	
– power fuses	8.2	
Reset totalizers	4.6	
Reverse flow (R)	4.4, 5.13	1.04-1.07
Revert to		
– functions column	4.1-4.3	
– main menu column	4.1-4.3	
– measuring mode	4.1-4.3	
– submenu column	4.1-4.3	
RS 232 interface	6.1	

Keyword	Section No.	Fct. No.
S		
S = Status output	2.2, 2.3, 4.4, 5.7	1.06, 1.07
Safety isolation	2.1	
Setting level	4.1-4.4	1.00 et seq., 2.00 et seq., 3.00 et seq.
Signal converter IFC 010		
– accuracies	10.2	
– cable A	1.3.1	
– changeover, power supply	8.2	
– connecting & operating points	4.2, 8.9	
– connection to power	1.2	
– functional checks	7.1-7.7,	
– fuses, power	8.2	
– mounting location	1.1	
– nameplates	10.5	
– operator control	4.1-4.3	
– power consumption	10.3	
– printed circuit boards	8.9	
– spare parts	9	
– technical data	10	
Simulator GS 8A	7.7	
SMU = low-flow cutoff	4.4, 5.3	1.03
Software	6.1	
Spare parts, see order numbers	9	
Status output S	2.2, 2.3, 4.4, 5.7	1.06, 1.07
T		
T = time constant	5.2	1.02
Technical data		
– accuracies	10.2	
– dimensions & weights	10.4	
– signal converter IFC 010	10.1, 10.3, 10.4	
Tests, see functional checks	7.1 et seq.	
Time constant (T)	5.2	1.02
Totalizer (internal electronic)	2.2, 5.7	1.06
Trip point	4.4, 5.8	1.06, 1.07
Troubleshooting, see functional checks	7.1 et seq.	
U		
Units for		
– display	4.4, 5.4	1.04
– flow	4.4, 5.1	1.01
– P	4.4, 5.7	1.06
User-defined unit	4.4, 5.12	3.05
V		
v = flow velocity	4.4, 5.1	3.02
VDE standards	page 0/4, 1.1 and 2.1 et seq.	
W		
Weights, see dimensions	10.4	
Z		
Zero check (adjustment)	7.1	3.03
ZD, intermediate connection box	1.3.5, 10.4	

If you need to return flowmeters for testing or repair to Krohne

Your electromagnetic flowmeter

- has been carefully manufactured and tested by a company with ISO 9001 certification
- and volumetrically calibrated in one of the world's most accurate test rigs.

If installed and operated in accordance with these operating instructions, your flowmeter will rarely present any problems.

Should you nevertheless need to return a flowmeter for checkout or repair, please pay strict attention to the following points:

Due to statutory regulations concerning protection of the environment and the health and safety of our personnel, Krohne may only handle, test and repair returned flowmeters that have been in contact with liquids if it is possible to do so without risk to personnel and environment. This means that Krohne can only service your flowmeter if it is accompanied

by a certificate in line with the following model confirming that the flowmeter is safe to handle.

If the flowmeter has been operated with toxic, caustic, flammable or water-endangering liquids, you are kindly requested

- to check and ensure, if necessary by rinsing or neutralizing, that all cavities in the flowmeter are free from such dangerous substances.
(Directions on how you can find out whether the primary head has to be opened and then flushed out or neutralized are obtainable from Krohne on request.)
- to enclose a certificate with the flowmeter confirming that the flowmeter is safe to handle and stating the liquid used.

Krohne regret that they cannot service your flowmeter unless accompanied by such a certificate.

SPECIMEN certificate

Company:

Address:

Department:

Name:

Tel. No.:

The enclosed electromagnetic flowmeter

Type:

Krohne Order No. or Series No.:

has been operated with the following liquid:

Because this liquid is

water-endangering * / toxic * / caustic * / flammable *

we have

– checked that all cavities in the flowmeter are free from such substances *

– flushed out and neutralized all cavities in the flowmeter *

(* delete if not applicable)

We confirm that there is no risk to man or environment through any residual liquid contained in this flowmeter.

Date: Signature:

Company stamp: