

KROHNE

09/94

Flowmeter

**Installation and
operating
instructions**

DWM 2000 FT

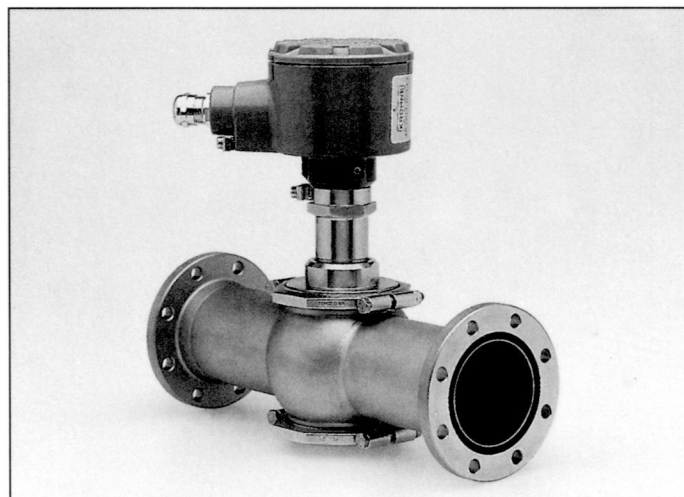
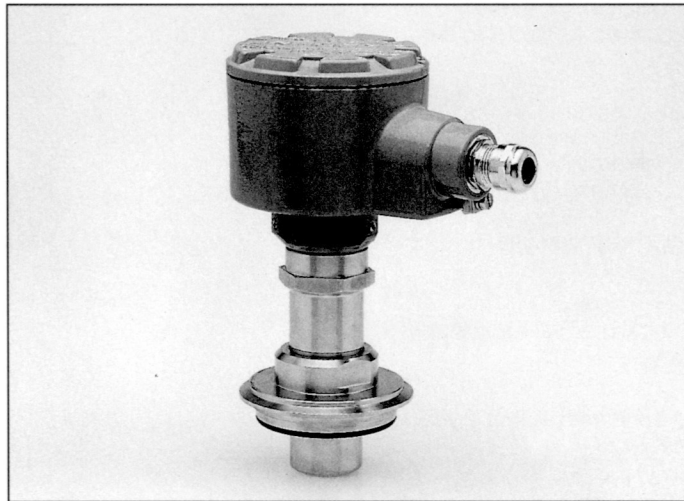

Krohne Messtechnik
GmbH & Co. KG
certified by



DWM 2000 FT flowmeter

The DWM 2000 FT flowmeter measures the flowrate of electrically conductive liquids, pastes and slurries.

Version

- DWM 2000 FT flowmeter, 4 – 20 mA current output

Special features

- Designed for Tuchenhausen VARIVENT® housings
- Wetted parts made of stainless steel (surface roughness $\leq 0.8 \mu\text{m}$), ceramics and FDA-approved EPDM, crevice-free
- Process temperature up to 135°C or 275°F
- With CIP/SIP capability
- Easy, quick and low-cost installation
- One device for all nominal pipe sizes
- Electromagnetic measuring principle, no moving parts
- Electronic unit replaceable under service conditions

Measuring principle

If an electrical conductor is caused to move in a magnetic field, such movement induces a voltage **U** in the conductor. In this case, the conductor is the electrically conductive liquid. Magnetic field **B** is at rightangles to the direction of flow. The induced voltage **U** is directly proportional to the local flow velocity **v**.

$$U = k \times B \times v \times D$$

k Instrument constant
B Strength of magnetic field
v Local flow velocity
D Electrode spacing

Voltage **U** is tapped off from the electrodes, neutral and ground electrode (socket).

DWM 1000 flow switch

Voltage **U** converted into a switching signal with adjustable switching point.

DWM 2000 flow monitor

Voltage **U** converted into a flow-proportional output signal, load-independent current 4-20 mA.

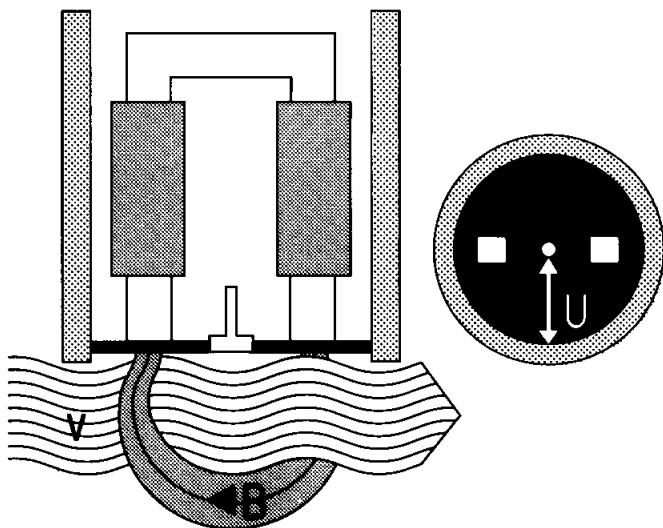

DWM 2000 FT component parts

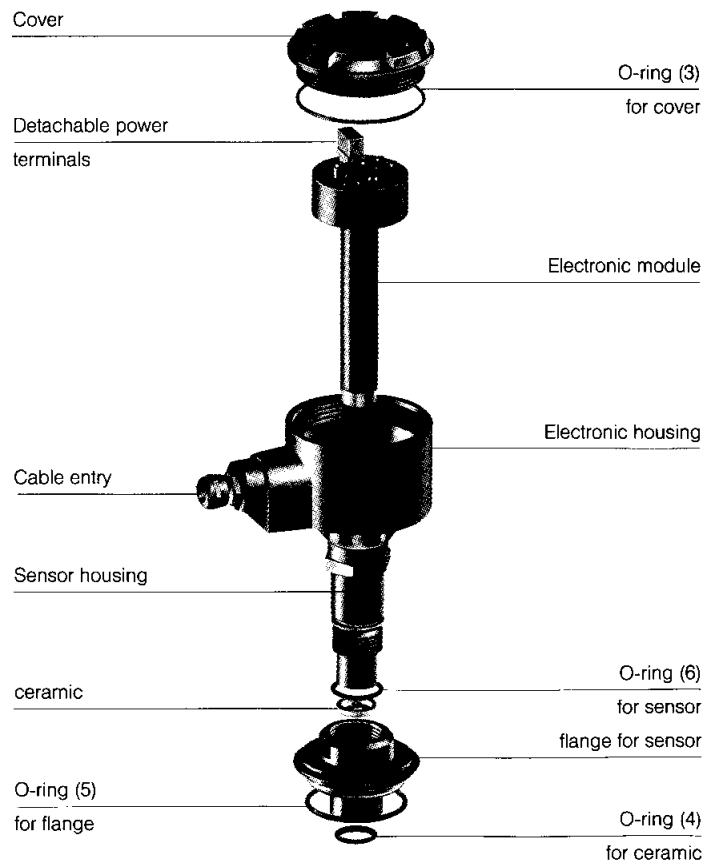

Installation

Installation in Tuchenhagen VARIVENT® housing (Pipe must be completely drained and depressurized)

- Unscrew the half-rings from the side of the VARIVENT® housing to which the DWM 2000 FT is to be fitted.
- Remove cover plate from VARIVENT® housing.
- Unscrew cover from the DWM 2000 FT.
- Fit the DWM 2000 FT into the VARIVENT® housing so that the "flow direction" arrow on the electronics unit points in the direction of flow.
- Refit the half-rings to the housing, making sure that the DWM 2000 FT is firmly positioned.
- The electronics housing of the DWM 2000 FT is rotatable and can be aligned in readiness for the electrical connection. Align by means of the three Allen screws on the outside of the housing.
- Connect the ground of the electronics housing to the ground of the sensor housing.

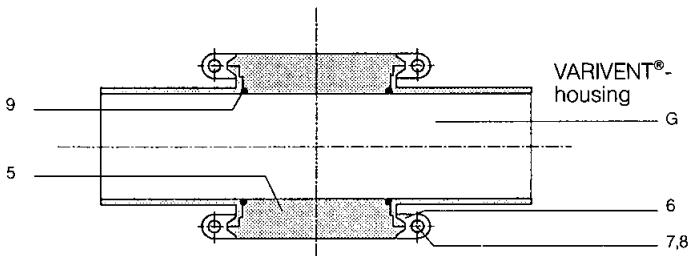

- 5 Cover
- 6 half-ring (standard)
half-ring in cast iron
- 7 Hex. screw
- 8 Hex. nut
- 9 O-ring

Electrical connection and setting of the DWM 2000 FT

Connection and settings must be done in the following order:

1. Set the full scale before power is switched on.
2. Ensure that the pipeline is completely filled with process fluid and that there is absolutely no flow ($V = 0$).
3. Switch on the power and ensure resistance to ground is $< 10 \text{ Ohm}$.
4. Set the zero point.

Electronic module

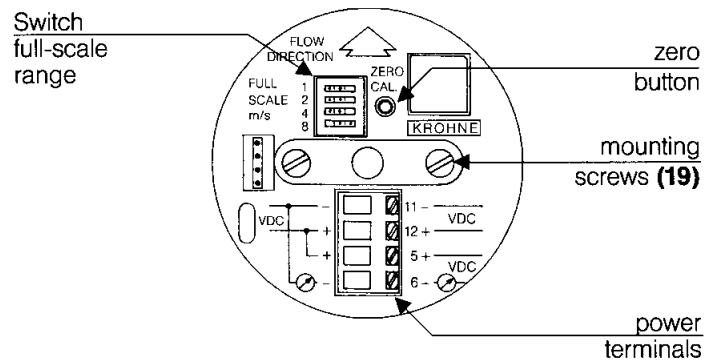

1. Setting the full-scale range

- The full-scale range is set using the "FULL SCALE" switches before connecting to power. The electronics will read the switch position after powering up.
- Refer to Diagram 1 for a rough estimation of the full-scale range in m/s: take your max. flowrate in m^3/h (X-axis) and follow the line up to the intersection with the "DN" nominal pipe size. Move left to the Y-axis to read off the full-scale range in m/s. Set this value with the switches (push in the direction of "FULL SCALE"). The sum of the numerical values of the set switches produces the full-scale value in m/s (see examples). Allowable values are 1, 2, 3, 4, 5, 6, 7 m/s. If the full-scale range is incorrectly set, i.e. above 7 m/s, the current output will remain below 3 mA even after approx. 1 minute power-up.

Electronics unit

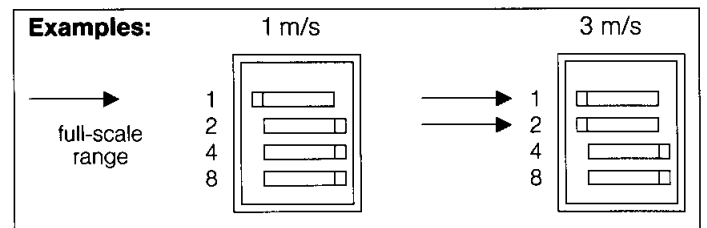
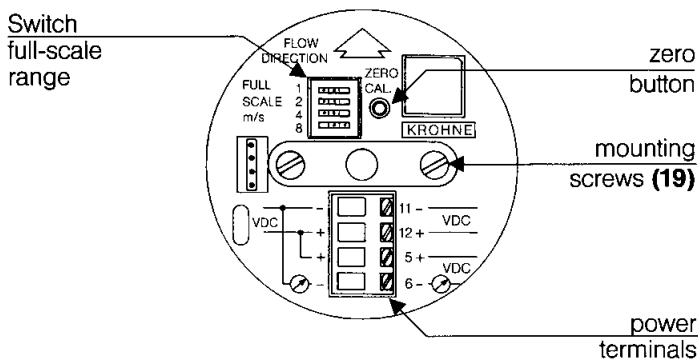
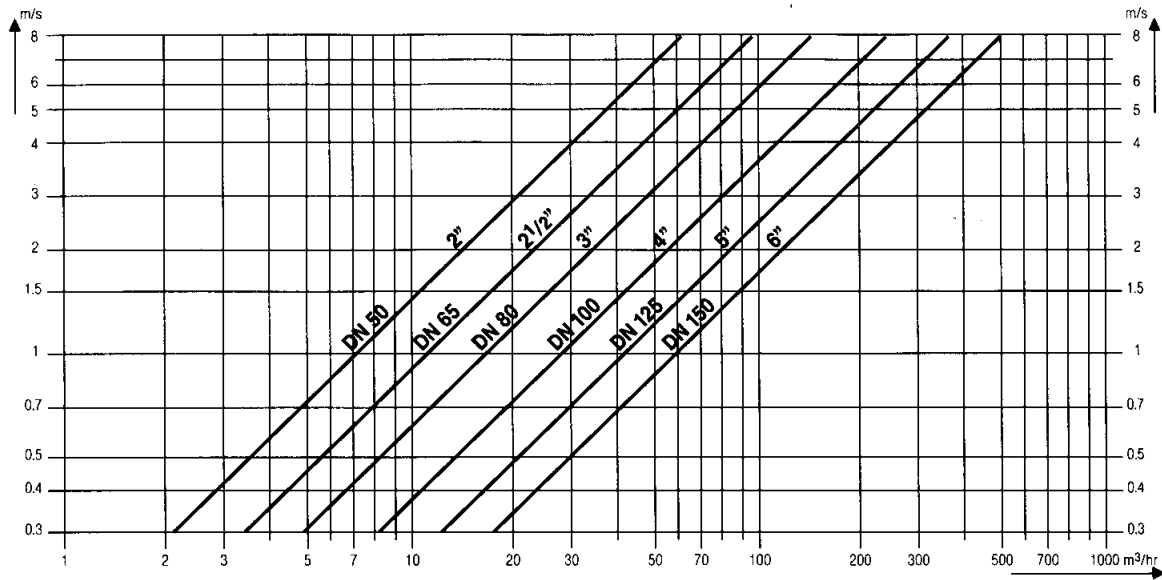

Diagram 1



2. Ensure that the pipeline is completely filled with process fluid and that there is absolutely no flow

3. Connect to power

- Make sure that the "FLOW DIRECTION" arrow is pointing in the direction of flow, otherwise incorrect measurements will result.
- To facilitate connection to power, the upper part of the power terminals can be removed.
- Connect 24 V DC source (optionally 12 V DC) to terminals 11 and 12 (max. 1.5 mm wire cross-section).
- Current output: terminals 6(-) and 5(+). Note polarity! Max. load < 500 ohms.
- One power source can be used for powering both the DWM 2000 FT and the passive current output (see connection diagrams).
- After powering up, the DWM 2000 FT will carry out a self-test. For about 1 minute the current output will go to a value of < 3 mA. If no electronic fault is established and if the full-scale switches are < 8 m/s, the current output will subsequently go to 4 mA. If there is a fault, the current output will remain at a value < 3 mA.

4. Zero adjustment

- Ensure that pipe is full.
- Flow velocity in the pipe must be "ZERO"!
- Press button "ZERO CAL". The current output will go for about one minute to a value below 3 mA. During this time, zero will be adjusted automatically and the current output will go to 4 mA.

Connection diagrams

Common power supply

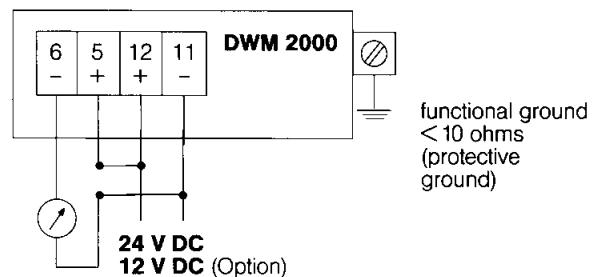

Separate power supplies

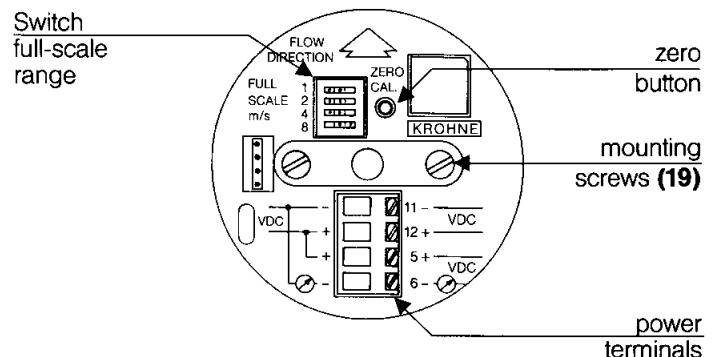
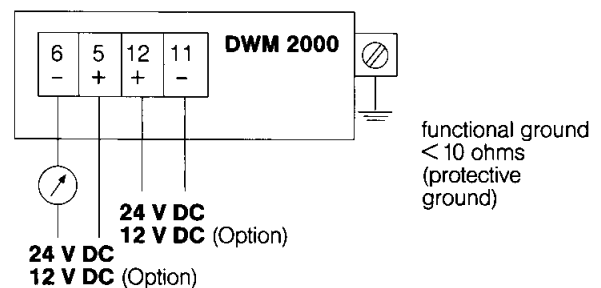

Replacing the electronics module

Disconnect from power before opening the electronics housing!

Dismantling:

- Unscrew the cover and disconnect the power and signal cables.
- Remove the 2 screws (19).
- Pull out the electronics module by its clip between the 2 screws (19).

Fitting:

- When inserting the electronics module into the sensor housing, make sure that the two screws (19) are positioned exactly above the threaded holes in the rotating ring.
- Screw in screws (19) but do not tighten down yet.
- Turn the electronics module by its clip until the "FLOW DIRECTION" arrow points in the direction of flow.
- Tighten down screws (19) firmly.

IMPORTANT: Both full-scale range and zero point must be readjusted (refer to page 3: "electrical connection and setting of the DWM 2000 FT").

- Connect to power and screw down the cover.

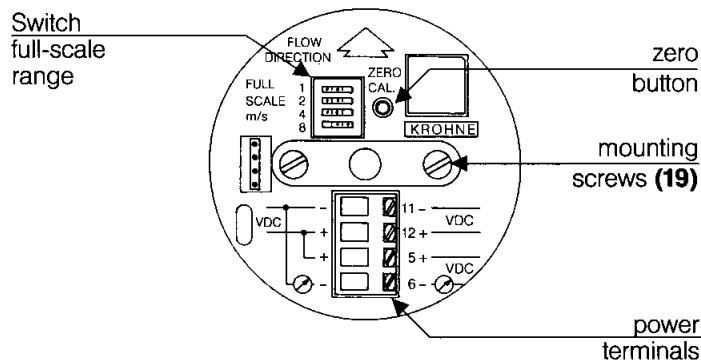

Changing the process-wetted O-rings

Pipeline must be completely drained and depressurized!

Dismantling:

- Remove electronics unit (see left).
 - Remove the DWM 2000 FT from the VARIVENT® housing (unscrew the half-rings).
 - Use two spanners (size 46 and 41 mm) to unscrew the bottom part with sensor flange from the sensor housing.
 - From below, gently ease the "ceramic" in the direction of the sensor flange.
 - Remove O-ring (4).
 - Remove O-ring (5).
 - Remove O-ring (6).
- Clean parts and/or replace with new ones.

Fitting:

- Use only grease approved by the food industry.
- Refit O-ring (4) (without greasing).
- Lightly grease O-rings (5) and (6), and refit.
- Lightly grease thread (7).
- Place the top part of the device in a vertical position (sensor housing on top).
- Position the "ceramic" such that its process-wetted side faces upwards.
- Slide the sensor flange over the "ceramic" and the sensor housing. Screw both parts together by hand and then tighten firmly with two spanners. The O-ring (4) must project very slightly to the front.
- Check the O-ring (4) for leak-tightness!
- Refit the electronics unit (see above).

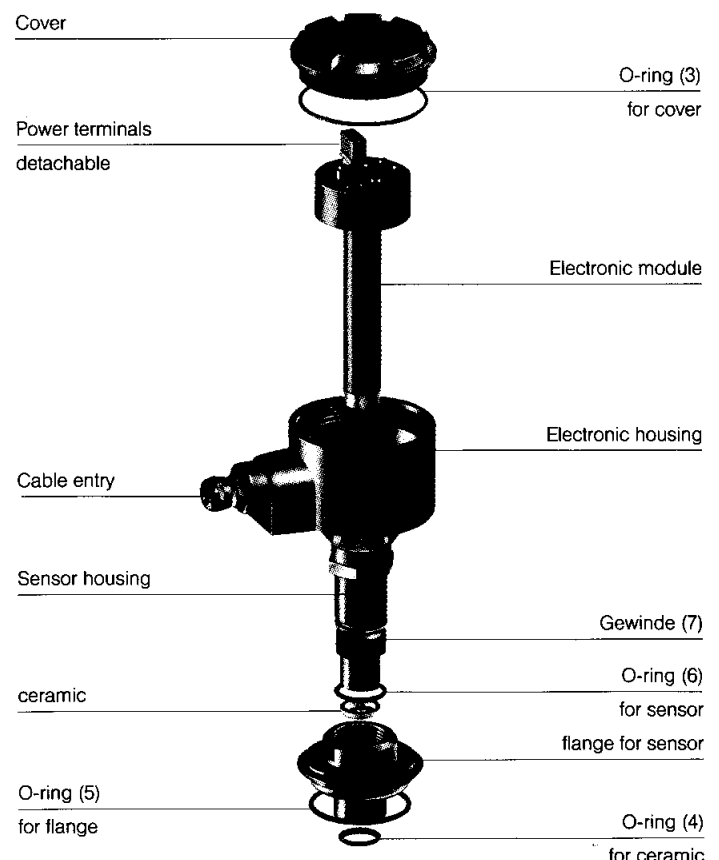

Technical data

Responsibility as to suitability and intended use of our instruments rests solely with the purchaser.

Instrument type	Flowmeter DWM 2000 FT
Power supply Voltage Power consumption Functional ground FE (protective ground)	24 V DC (20 – 30 V DC). Option: 12 V DC (term. 11/12) ≤ 50 mA (at 24 V DC) < 10 ohms
Output	passive current output 4 – 20 mA, (term. 5/6) 24 V DC (20 – 30 V DC) load: max. 500 ohms
Full-scale range "v"	1/2/3/4/5/6/7 ms, adjustable
Time constant	5 seconds, fixed
Repeatability	1% of measured value
Measuring error v > 1 m/s v < 1 m/s	± 3% of measured value ± (2 cm/s + 1%) of measured value
Operating data Liquid product Electrical conductivity Operating pressure Process temperature Ambient temperature	largely homogeneous liquids, pastes and slurries, also with solids contents ≥ 20 μS/cm (< 20 μS/cm on request) ≤ 15 bar - 25 to + 135°C - 25 to + 60°C
Installation in VARIVENT® housing Nominal sizes Inlet/outlet runs	DN 50 – 125, 2" – 4" OD, 2" – 6" I.P.S. 10 x DN / 5 x DN, dependent on flow profile (DN = nominal pipe size)
Protection category (IEC 529 / EN 60529)	IP 66
Cable entry	PG 13.5
Power terminals	wire diameter max. 1.5 mm ²
Materials <u>Sensor</u> <u>Housing</u> <u>Electrode</u> <u>Cable entry</u> <u>Gasket housing/cover</u>	stainless steel 1.4404, surface roughness ≤ 0.8 μm, with ceramic insulation (zirconium oxide) and EPDM gasket, FDA-approved (others on request) die-cast aluminium with epoxy resin finish platinum polyamide buna N

Weight: 2.25 kg

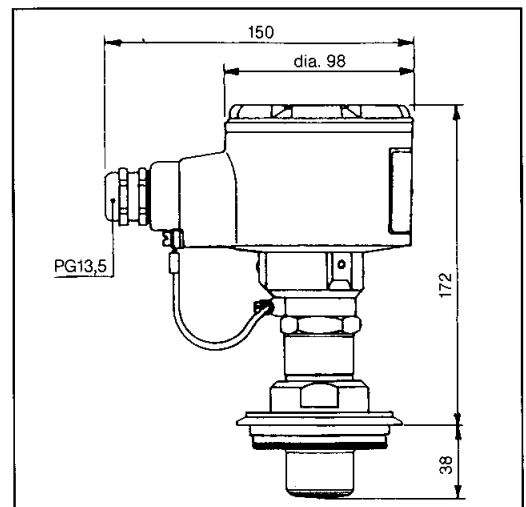
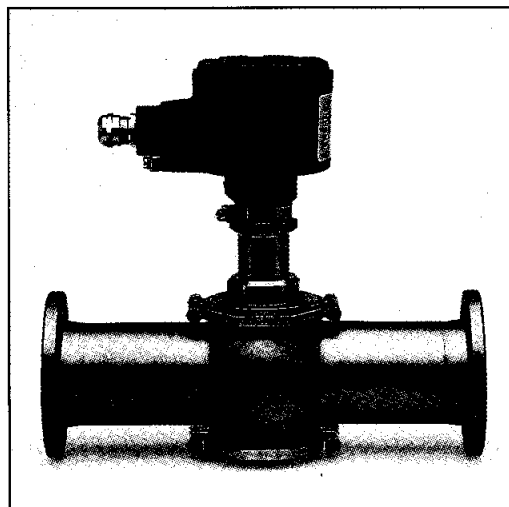

Spare parts:

