

**KROHNE**

12/97

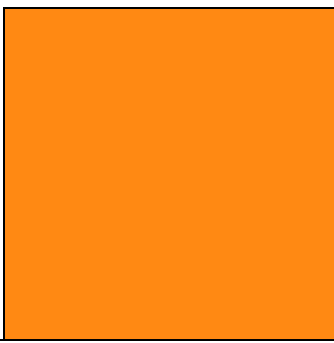

# Electromagnetic Flow Switch and Flow Meter

**Installation and  
Operating  
Instructions**

**DWM 1000  
DWM 2000  
DWM 2000 L  
DWM 2000 IP68**



KROHNE S.A.  
CERTIFIED  
ISO 9001



---

# Contents

	<b>Page</b>
<b>Introduction</b> .....	3
Special Features	
Measuring Principles	
Components	
<b>Installation</b> .....	4
Mounting on Pipeline	
Dimensions and Weight	
<b>Electrical Connection and Settings</b>	
DWM1000.....	5
DWM2000.....	6
<b>Compatible Relays (for DWM1000)</b> .....	7
<b>Zone 2 Information</b> .....	7
<b>Version DWM2000 IP68</b> .....	8
<b>Version DWM2000 Long</b>	
Characteristics .....	8
Components.....	8
Installation.....	9
<b>Trouble Shooting</b> .....	10
<b>Technical Data</b> .....	11
<b>KROHNE Contact Addresses</b> .....	12

# DWM Flowmeters and Switches

The DWM electromagnetic flowmeters and switches are designed to measure and monitor the flowrates of electrically conductive liquids, pastes and slurries.

## Versions

- n DWM 1000 flow switch, 2-wire system.
- n DWM 2000 flowmeter, 4-20 mA current output/readout.
- n DWM 2000 L (Long) for flow pipes of greater than 400mm diameter or open channels.
- n DWM 2000 IP68 for immersed applications.
- n DWM 2000 Zone 2 for hazardous environments.
- n DWM 2000 FT for food applications with Tuchenhausen connection (detailed in a separate instructions leaflet).

## Special Features

- n Rugged design, IP66 protection, equivalent to NEMA 4 and 4X standards.
- n All wetted surfaces of ceramic, stainless steel and platinum.
- n Compatible with process temperatures up to 150°C (300°F), and ambient temperatures between - 25 à + 60°C
- n Suitable for operating pressures up to 25 bar (360psi).
- n No moving parts, maintenance free.
- n Electronic unit replaceable without interruption of flow.
- n Compatible for all pipelines with nominal diameter (DN) ≥ 50mm (2").
- n Readout connection possible with handheld consoles (DWM 2000 only).

## Measuring Principle

If an electrical conductor moves through a magnetic field, a voltage, **U**, is induced in the conductor. In the case of the DWM, the liquid in the flow pipe is the electrical conductor. In the diagram below, the DWM creates the magnetic field, **B**, perpendicular to the direction of flow. The induced voltage **U** is directly proportional to the local flow velocity **v**.

$$U = k \times B \times v \times D$$

**k** - Instrument constant  
**B** - Strength of magnetic field  
**v** - Flow velocity  
**D** - Electrode spacing

Voltage **U** is tapped off from the electrodes, neutral and ground electrode (connection socket)

**DWM 1000 Flow Switch** - Voltage **U** is converted into a switching signal with adjustable switching point.

**DWM 2000 Flow Meter** - Voltage **U** is converted into a flow-proportional output signal current between 4-20 mA (load independent).

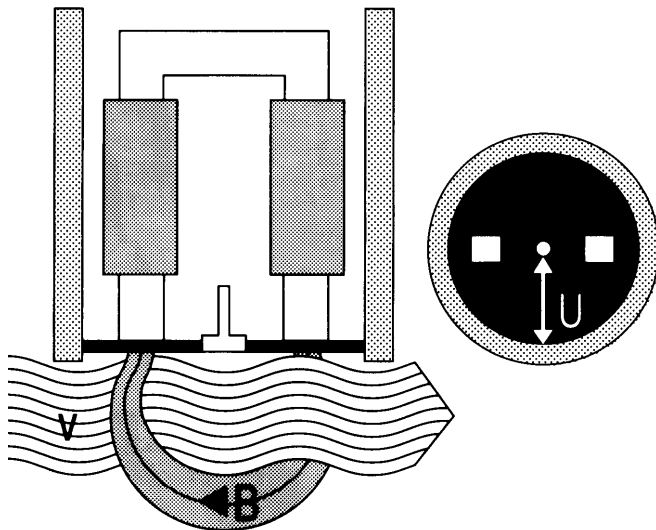

## Components of DWM 1000/2000

- 1 Connection Socket
- 2 Gasket
- 3 Sensor
- 4 Threaded Connection (1")
- 5 Earthing Cable
- 6 Earth Clamping Strap
- 7 Cable Entry Gland PG 13,5
- 8 Housing
- 9 Blanking Plug
- 10 Supply Terminals
- 11 Connection Chamber
- 12 Magnetic Coils and Electrode Contacts
- 13 Electronic Unit
- 14 Cover Screws
- 15 Cover With Fitted Gasket

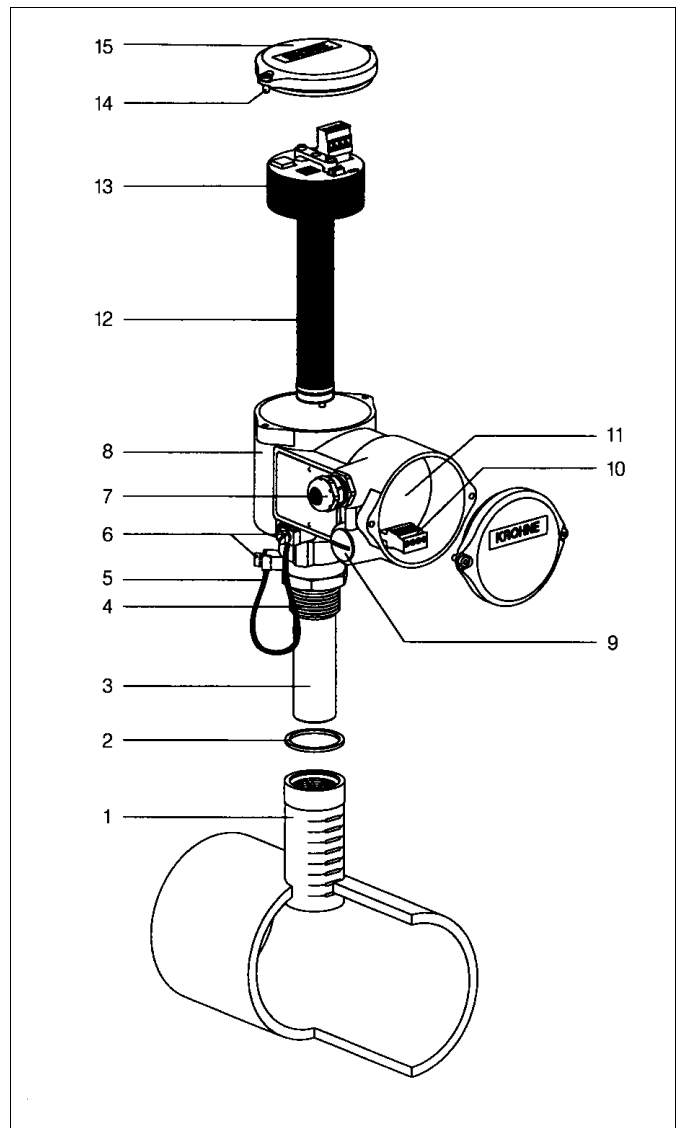

# Installation

## Mounting onto the pipeline

- n The DWM should be mounted onto the pipeline (nominal diameter (DN)  $\geq 50\text{mm}$  (2")) by means of the connection socket provided.
- n Refer to the diagrams below for the orientation and positioning of the connection socket. The socket should be inserted as far as the corresponding pipeline diameter (DN) marking. In the case where there is pipe insulation, it is necessary to calculate the depth of insertion so that the protrusion of the probe is 1/8th of the true internal diameter (i.e. not the DN).
- n The location hole in the pipeline should be drilled to a diameter of 39 mm (1.54") with a maximum of 0.5mm play between the socket and bore. Secure the socket perpendicular to the pipe with four spot welds, then carry out an unbroken weld of the entire diameter, with an electrode of 1.2mm diameter and setting of 90 to 150A.
- n The straight line flow distance required between the DWM and an upstream flow disturbance (inlet, pump, elbow etc) is advised to be 10 x DN and 5 x DN from downstream disturbances.
- n The DWM must be installed into the socket using the supplied gasket, which ensures watertightness and flush positioning of the ceramic probe head. Teflon tape should not be used on the thread as this insulates the required earthing contact, and prevents the correct protrusion of the probe.
- n Only the electronics unit must be rotated according to the flow direction (see "Electrical Connection and Setting").

## Installation On Plastic Pipes

In the case where the unit is to be installed on a plastic flow pipe, it is necessary to assure an earth connection. In all cases consult KROHNE to ensure an effective solution.

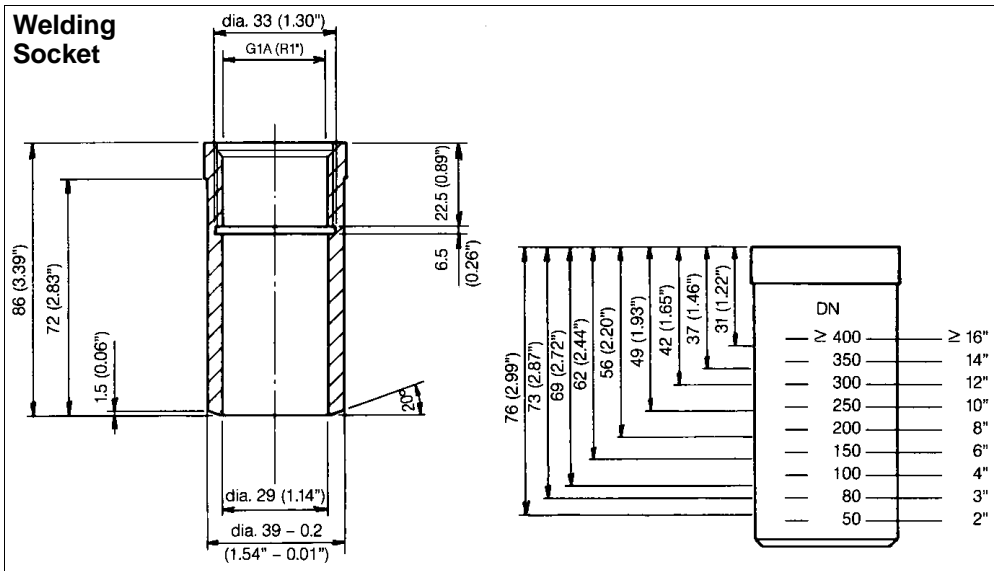

## Correct

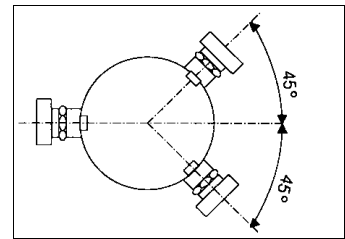

## Incorrect

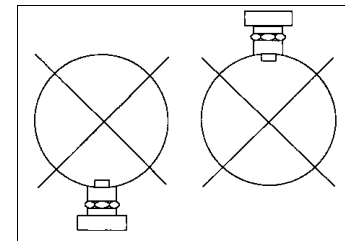

## Dimensions and Weight

Diecast aluminium housing - weight excluding socket approx. 1.85Kg (4.08lbs)

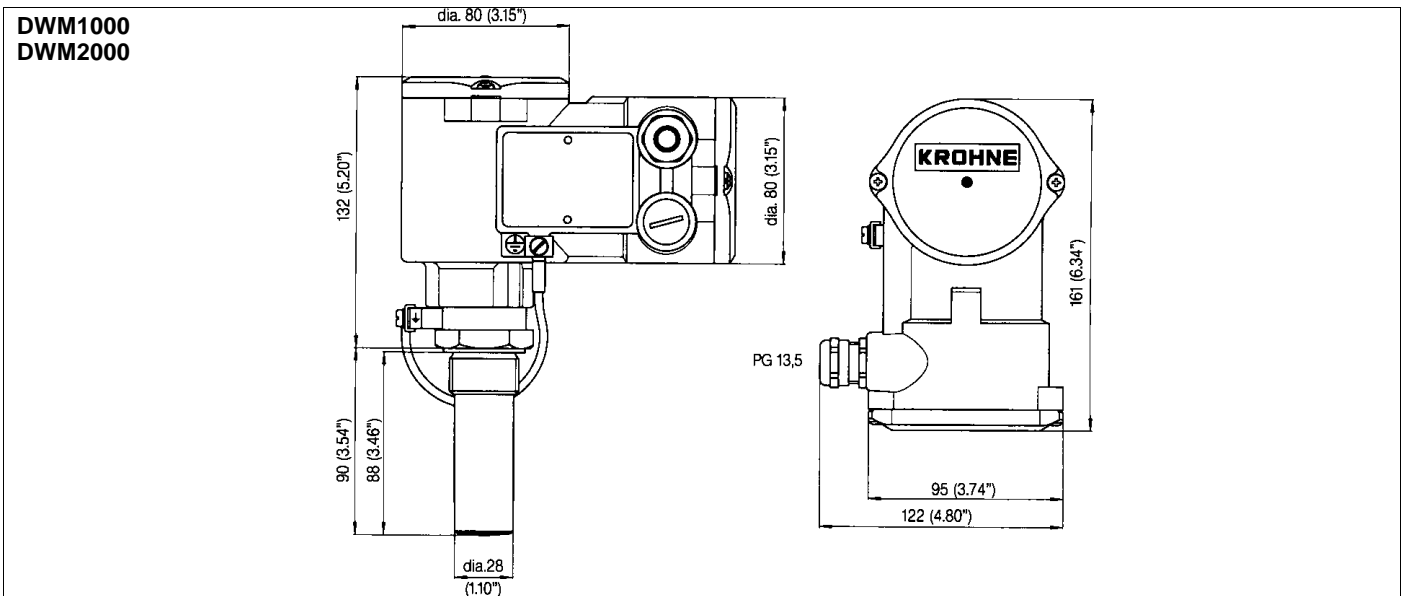

# Electrical Connection and Settings

## Electrical Connection

- n The wiring terminals for the DWM can be found in the connection chamber (as shown below).
  - n The electrical connection conforms to the standard EN61010-1, protection class 1, voltage category III, interference degree 2.
  - n The DWM range conforms to EMC directives NF EN 50 081.1 (Emission) and NF EN 50 082.2 (Immunity)
  - n It is obligatory to earth the connection in the chamber, and to have a switching or circuit breaking device, following present regulations. The devices should completely isolate the unit and be easily accessible, close to the unit.
  - n DWM1000 - Both the live (L) and neutral (N) wires should be protected by a fuse (4 to 6.3A T). During the wiring procedure the earth wire should always be connected first. The external diameter of the wiring cable should be between 6 and 12mm.
- N.B.** - The use of the DWM outside of the specifications detailed in this manual can compromise the security of the unit.  
 - When at any time it is necessary to access the connection terminals, disconnect the power supply.

## DWM1000 Flow Switch

- n Terminals 1 and 2 are used for the electrical connection (wire cross-section: max. 1.5mm<sup>2</sup> or 16 AWG). Polarity is arbitrary.
- n The flow switch must not be connected to power without an electrical load in series (e.g. relay)!
- n The choice for the alarm status NO (circuit open for velocity higher than reference velocity) or NC (circuit open for inverse function) can be changed by the switching as detailed on the right.
- n If more than one DWM1000 is used, make sure they are not connected in parallel. Only one common return is allowed. Provide a separate fuse for each flow switch.
- n Ensure that the earthing of the unit is <10 Ohms.

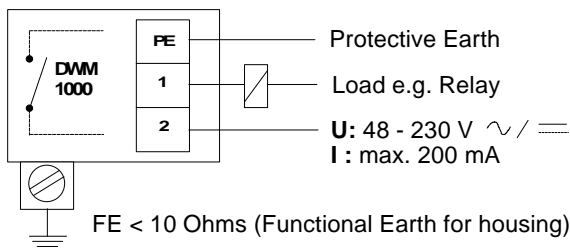

## Relay Limits

- n Always ensure that the voltage and relay voltage correspond with compatibility specifications. Refer to the 'Compatible Relay' section for the choice of relay on page 7.

## Settings

- The settings have to be carried out in the following order:
  - n Positioning of the electronic block.
  - n Setting of reference velocity.
  - n Setting of the time constant.
  - n Setting of the alarm status: NO or NC.

Open the housing and unscrew the two mounting screws (14) of the electronic block (only two turns) without taking them out. Position the block aligning the arrow with the direction of flow in the pipe (if not aligned false readings will occur). The block is then fixed by fully tightening the mounting screws.

## Setting of the Reference Velocity

Set the reference velocity with the two dials (11), one for the m/s units and the other for the 1/10ths units.

## Setting of the Time Constant

Set the time constant with the dial (12) to 5, 8 or 10 seconds. Depending on the desired function of the unit, program the time constant to the largest possible, to avoid unnecessary switching during fluctuations in the flow rate.

## Setting of the Alarm Status

The alarm status can be selected with the inverter (13).  
 NO - circuit open for velocity higher than reference velocity.  
 NC - circuit closed for velocity higher than reference velocity.  
 The LED flashes when the circuit is open.

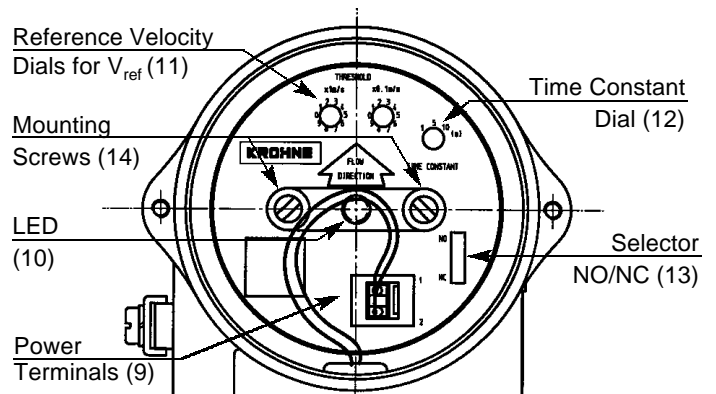
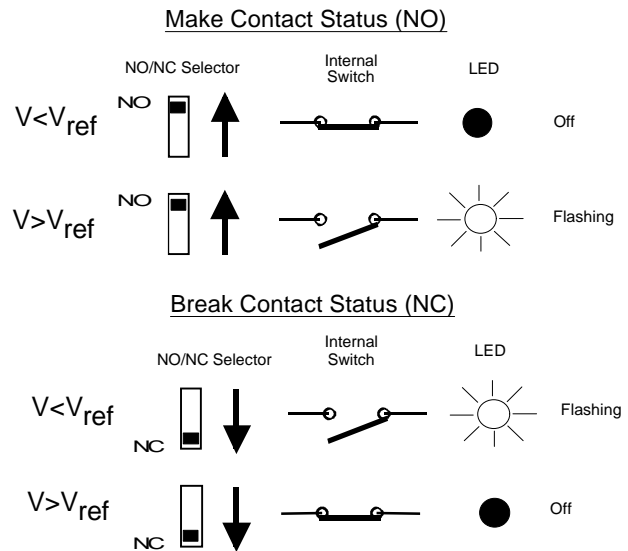

## Installation on Piping With Cathodic Protection

Please contact KROHNE directly for instructions.

## Removal and Remounting of the Electronic Block

The electronic block may be removed in security during flow conditions, as the probe is fully sealed. Before removing the unit ensure that the power supply is switched off. Unscrew the two mounting screws fully (14), and pull the block by means of the plastic bridge.

To replace the block, it should be orientated so that the screws (14) engage into the threads of the rotating sleeve, and secured in place with a few turns. Next orientate the block so that the arrow is in line with the flow direction, and lock the block by fully tightening the mounting screws.

Note - the replacement block needs to be calibrated.

# Electrical Connection and Settings

## DWM2000 Flowmeter (current output)

The connection and settings have to be carried out in the following order:

- n Positioning of the electronic block.
- n Setting of the full scale.
- n Electrical connection and earthing (must be <10 Ohms).
- n Zero adjustment.

### Positioning of the electronic block

Open the housing and unscrew the two mounting screws (14) of the electronic block (only two turns) without taking them out. Position the block aligning the arrow with the direction of flow in the pipe (if not aligned false readings will occur). The block is then fixed by fully tightening the mounting screws.

### Setting of the Full Scale

The setting of the full scale has to be done before powering up the DWM2000! Full scale range is from 1 through to 8m/s, and is set by means of the 1, 2, 4 and 8 value switches. The final value of the full scale is the sum of the switches activated. The switch has to be at the side of the inscription to be activated. If the full scale is set improperly (i.e. >8m/s), the device will be in alarm status (output current <3mA).

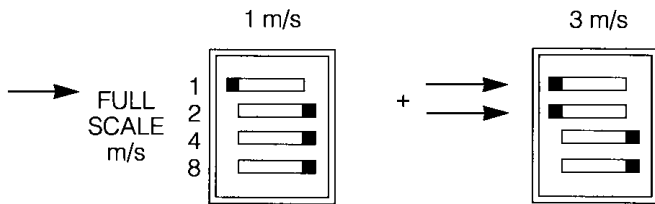

### Connection

- n Power the unit with 24VDC (power terminals marked 11 (-) and 12 (+)). Maximum wire diameter is 1.5mm.
- n The power consumption at 24VDC is 50mA (max at 20°C)
- n Power the current output with 24VDC (power terminals 6 (-) and 5 (+)). Beware of polarity! Max. load is 500 Ohms.
- n One power supply can be used to supply the DWM2000 and current output (see diagram).
- n After powering the DWM2000 will do a self-test (1 minute), during which current output will be in alarm state (<3mA). If the self-test is OK the DWM2000 will start measuring, if not, the output will remain in alarm state (<3mA).

### Zero Adjustment

Ensure that the pipe is full. There should be no flow velocity in the pipe. Press the "Zero" key. After 1 minute, the zero setting will be automatically adjusted. During zero calibration, the output indicates alarm status (<3mA).

### Piping With Cathodic Protection

Please contact KROHNE directly for instructions.

### Removal and Remounting of the Electronic Block

The following procedure must be carried out by a qualified technician:

The electronic block may be removed in security during flow conditions, as the probe is fully sealed. Before removing the unit ensure that the power supply is switched off. Unscrew the two mounting screws fully (14), and pull the block by means of the plastic bridge.

To replace the block, it should be orientated so that the screws (14) engage into the threads of the rotating sleeve, and secured in place with a few turns. Next orientate the block so that the arrow is in line with the flow direction, and lock the block by fully tightening the mounting screws.

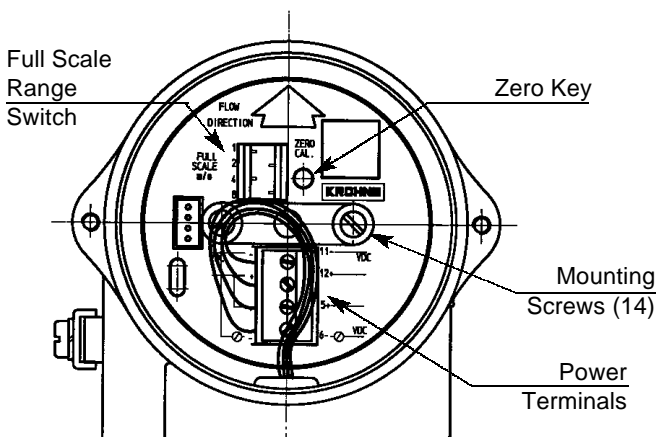

### Electrical Wiring

#### Common Power Supply

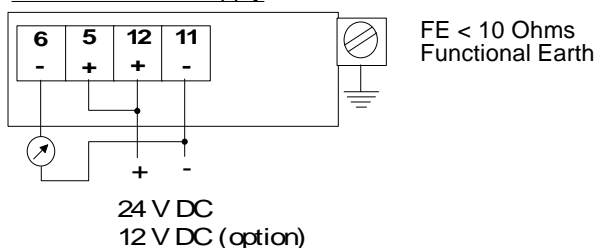

#### Separate Power Supplies

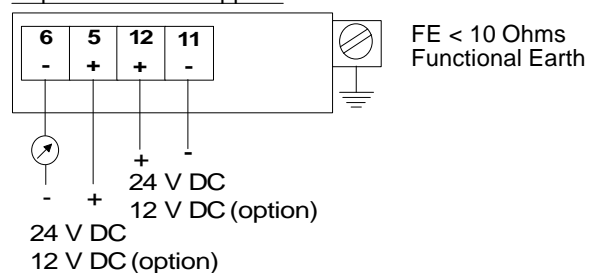

### Reminder for Flow Volume Calculations:

$$V = 354 \times \frac{Q}{D^2}$$

V = m/s  
Q = m<sup>3</sup>/h  
D = internal pipe diameter in mm

**Note:** for Zone 2 applications, a fuse is required for the positive (+) output with a rating ≤200mA.

# DWM 1000 Compatible Relays

This list includes those relays tested by KROHNE, and is not exhaustive.

RHZ32 references indicates the type of filter (TELEMECANIQUE RC or equivalent) that should be mounted in conjunction with the relay, and RHZ-21 the type of base required.

<b>Manufacturer</b>	<b>Reference</b>	<b>Power supply (tested range)</b>	<b>Further Detail</b>
TELEMECANIQUE	LC1D0910M7	230 VAC (+/- 10%)	
TELEMECANIQUE	CA2DN22M7	230 VAC (+/- 10%)	
TELEMECANIQUE	LC1K0610M7	230 VAC (+/- 10%)	
Klöckner MOELLER	DILR40	230 VAC (+/- 10%)	
Klöckner MOELLER	DILR22	230 VAC (+/- 10%)	
Kuhnke	PA	230 VAC (+/- 10%)	
TELEMECANIQUE	CA3KN40GD	125 VDC (+/- 20%)	
TELEMECANIQUE	RHN411F (RHZ32 + RHZ-21)	110 VAC (+/- 10%)	
TELEMECANIQUE	CA3KN40FD	110 VDC (+/- 20%)	
TELEMECANIQUE	RHN412 E (RHZ32 + RHZ-21)	48VDC (+/- 20%)	Does not switch until 46V
TELEMECANIQUE	CA2EN240E (RHZ32)	48VDC (+/- 20%)	Does not switch until 43V
TEC Bristol Babcock	19JU (RHZ32 only at 48V)	38 VDC or 230 VAC	

# DWM2000 Zone 2 Requirements

The symbol X at the end of the marking code of a Zone 2 instrument indicates that the relevant installation conditions must be respected. In brief these are:

- n The aluminium housing must be earthed. The housing is equipped with a connection which takes wire diameters upto 4mm.
- n A fuse of less than 250mA must be installed on the positive power supply line (terminals 5 and 12 on page 6).
- n The housing cover seals must be in a dust free and well greased condition. This ensures the air-tightness of the unit which is required for Zone 2.
- n A cable with an outer diameter of between 8 and 15mm is necessary, ensuring full sealing of the cable entry gland.
- n The instrument is equipped with protective components which conduct if the voltage between the protective earth and one of the 4 terminals exceeds 39VDC.

# DWM 2000 IP68

The version IP68 is supplied as a sealed unit, with all calibration carried out before delivery. The customer has to be aware in particular that the cable packing gland must not be opened as it is specially sealed according to regulations.

Ensure to install the unit onto the flowpipe before connecting the cable, as the cable needs to be free during the rotation of the unit. The unit must be installed with the flow arrow marked on the top of the housing aligned with the flow in the pipe.

For the wiring of the versions IP68, see the two diagrams below, showing the two options of a common or separate power supplies. The numbering correspond to the following wire colours: 11 - Brown; 12 - Red; 5 - Orange; 6 - Yellow

For all electrical information refer to DWM2000 Technical Data specifications on page 11.

The DWM 2000 IP68 can also be ordered with extended probe, as detailed below in the DWM 2000 L.

## Wiring:

### Common Power Supply

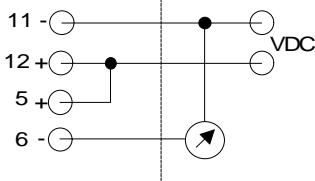

### Separate Power Supply

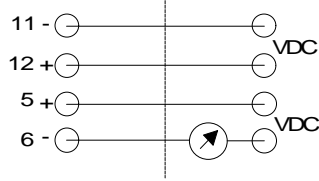

11 - brown; 12 - red; 5 - orange; 6 - yellow

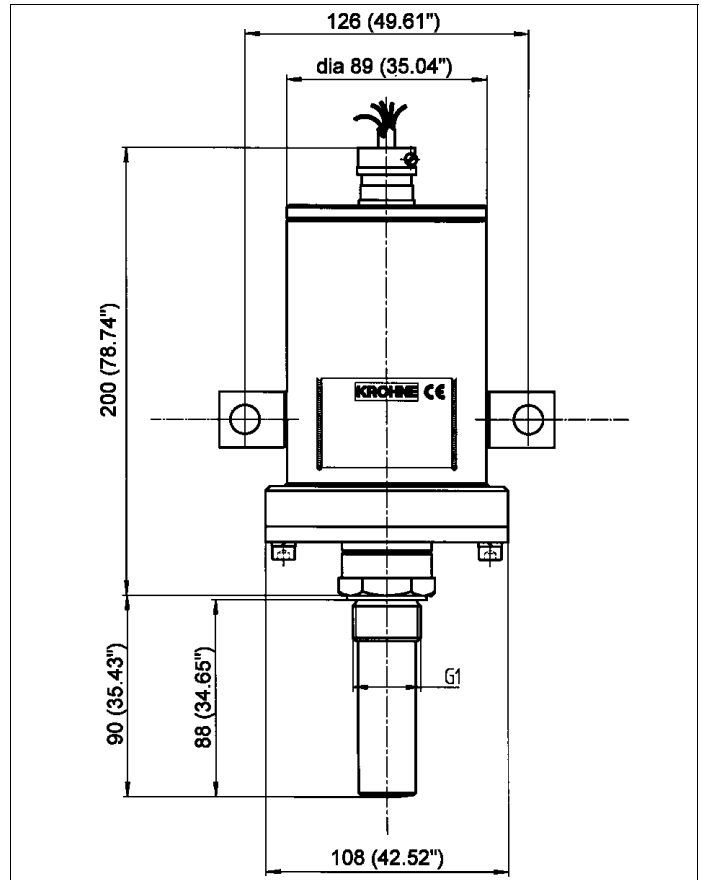

# DWM 2000 L

## Characteristics

Same characteristics as DWM2000 but adapted for the following special conditions:

- n Velocity measurement in open channel. Combined with ultrasonic level measurement gives flow volume measurement.
- n Flow control in pipes or open channels.
- n Spool piece mounting, T-mounting.
- n Option: Hot-tap mounting, equipped with isolation valve.
- n Option: adjustable high pressure screw connection with security chain for mounting and dismounting.
- n Can be used instead of insertion turbines, flowcontrollers.
- n Possibility to measure velocity at different points in open channels, rivers etc.
- n Probe lengths upto 3m possible.
- n Easy to transport in order to carry out field tests.
- n Protection class IP67.
- n Special option IP68 with submerged converter.

**Max Product Temperature:** 150°C (IP67), 60°C (IP68)

**Max Operating Pressure:** 25 bar

**Ambient Temperature Range:** -25°C to + 60°C

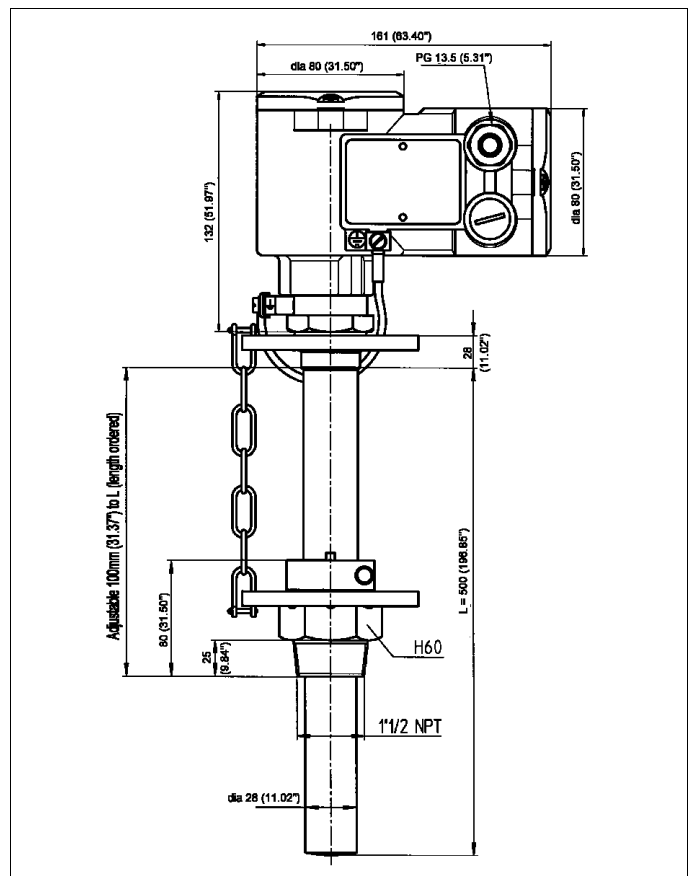

# DWM 2000 L - Installation

## A. Installation on Flow Pipes

- n The straight line flow distance required between the DWM and an upstream flow disturbance (inlet, pump, elbow etc) is advised to be 10 x DN and 5 x DN from downstream disturbances.
- n Position the pipe saddle or the welding socket as indicated in the installation sketch.
- n Screw the ball valve onto the welding socket (or connection flange according to the saddle design). The valve thread is 1"1/2.
- n Ensure that the ball valve is closed.
- n Screw the adjustable fitting onto the ball valve.
- n Slide the DMW2000/L into the adjustable fitting to a depth of between 60 et 75mm. This assures that the mounting will be watertight.
- n The security chain is supplied to the required length as determined for each application. This length cannot be extended, but may be shortened where necessary.
- n Loosen screw (No. 2 in sketch below) slightly. This enables the DWM2000/L to be inserted further without any leakage.
- n Open the ball valve.
- n Calculate the penetration length (= 1/8 DN Nominal Diameter) with a tolerance of +2mm - 0mm.
- n If flow is heavily perturbed or the internal diameter is uncertain, it is advised to penetrate between 1/8 DN and 1/2 DN.
- n Insert the DWM2000/L until measurement position is reached.
- n Take off the housing cover and turn the entire probe so that the arrow points in flow direction (this system differs from standard DWM 1000/2000).
- n Tighten alternatively the two screws (No.3 in sketch) up to max 3N/m, to seal off the fluid. Complete the installation by tightening screw (No.2).

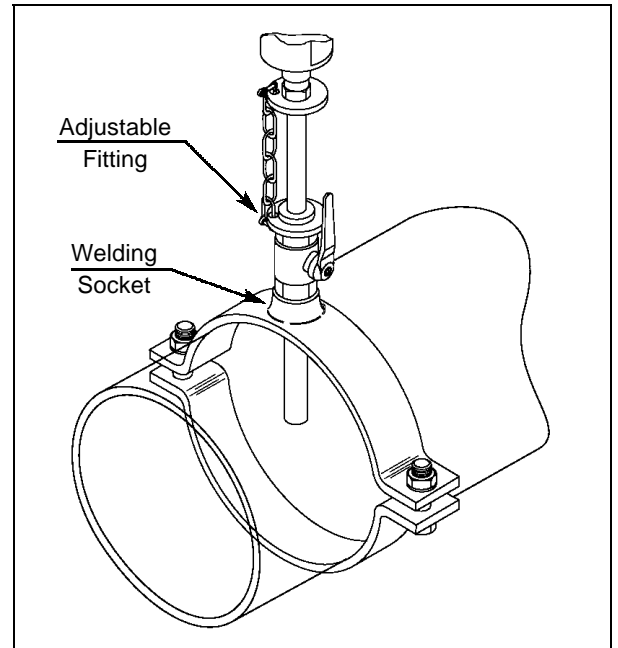

Installation on pipe saddle

Preferred mounting angle: horizontal  $\pm 45^\circ$

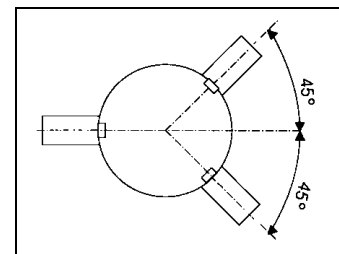

Installation with welding socket

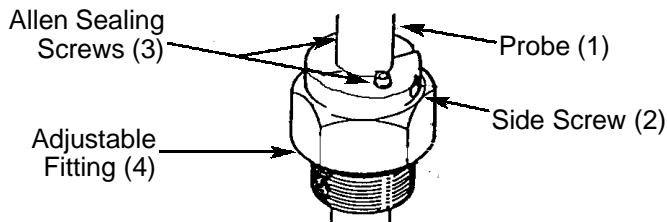

max. pressure 25 bar

## B. Installation on Open Channels

- n The DWM2000/L can be mounted by using the adjustable fitting.
- n Position the device in such a way that the arrow points in the flow direction.

### Remarks

- n The electronics block of this long version is interchangeable.
- n **For safety reasons, keep the security chain mounted, in order to avoid any ejection in case of overpressure in the pipe.**
- n For range settings and electrical connection, refer to DWM2000 standard version instructions.

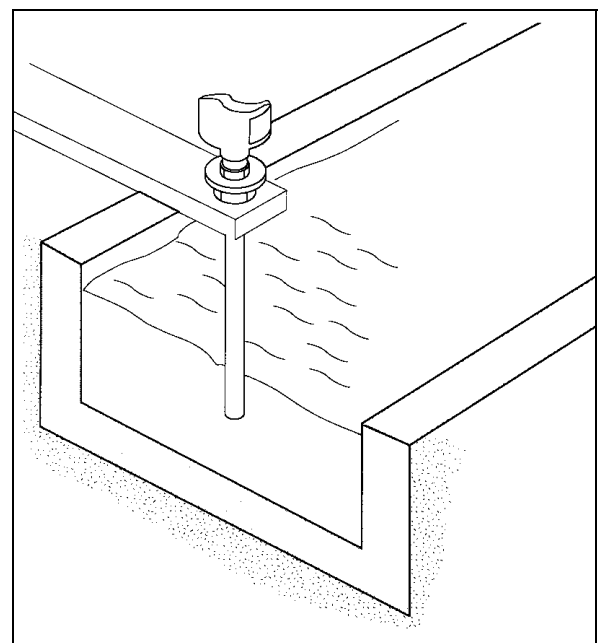

Installation in an open channel

# Trouble Shooting

Below is a list of possible problems, and the checks required for their resolution. In all cases ensure that the installation instructions have been followed e.g. supply voltage, relay compatibility (DWM1000 only), earthing (<10 Ohms), straight line flow distances, and flow in pipe is full.

## DWM 1000

Fault: The relay does not switch according to reference velocity.

### Checks

When the selector is inverted, does the relay switch?

Advance the reference velocity from 0 m/s through to 9m/s - does the relay switch?

### Action

If no, measure the consumption of the unit whilst the LED is illuminated. If  $i < 5.5\text{mA}$  for DC (12 mA for AC), insert a resistor in parallel with the relay coils of ratings 1, 3 or 10kOhms (5W) corresponding to voltages 48, 110, and 230V respectively. If no, and the LED changed state, replace the electronics unit. If yes, note the reference velocity value, and check this against the real velocity.

Fault: The relay switches randomly.

### Checks

Liquid heavily charged with particles? Flow speed close to 0.1m/s? Straight line flow distances too short? Air bubbles in liquid (at high temperatures)?

### Action

Increase the time constant to 10s. If results are the same, increase the reference velocity. If the results remain the same, insert a resistor in parallel with the relay coils of ratings 1, 3 or 10kOhms (5W) corresponding to voltages 48, 110, and 230V respectively.

## DWM 2000

Fault: The output current is fixed at 0mA.

### Checks

Output signal correctly powered?  
Polarity correct on supply connections?  
Liquid inside the probe body?

### Action

Refer to Technical Data specifications.  
Refer to wiring diagrams.  
Contact KROHNE Service Department.

Fault: The pipe flow is higher than 0.1m/s and the output current remains at 4mA (+/- 0.02mA).

### Checks

Orientation of the electronic unit correct?

### Action

Loosen the fixing screws, and align the arrow with the pipe flow

Fault: The output current is fixed at below 3mA.

### Checks

Power supply stable? (nominally +/-1%)  
Current at 2.0mA?  
Current at 2.4mA?

### Action

Change power supply.  
Reset the Full Scale switches to between 1 and 8m/s.  
Zero setting too large - reset the zero with the pipe full and  $v=0$  m/s.

For all other alarm output readings, contact KROHNE.

Fault: There is no flow in the pipe, and the output current is instable (4mA +/-1mA).

### Checks

Is the output current stable when tested by a multi-meter?  
Is the earth <10 Ohms?

### Action

If no, trace and eliminate the interference source.  
Establish a correct earthing point.

Fault: The output current is above 4mA, but the reading is incorrect.

### Checks

Reading above 24mA?  
Fluctuations, but average reading correct?  
Installation correct?

### Action

Ensure conformity to power supply specifications.  
Increase the time constant value using the HHC2000 console.  
Verify mounting specifications (probe penetration in pipe, right-angles, orientation of electronic unit).  
Ensure that the pipe is full during flow conditions.  
Check the internal diameter of the pipe and reset the Full Scale.  
Test the output current with the HHC2000 console.

Pipe not full?

Speed/flow calculations correct?  
Is the output current correctly calibrated?

# DWM Technical Data

	<b>DWM 1000 Flow Switch</b> Two Wire System	<b>DWM 2000 Flow Meter</b> Output Current 4 - 20 mA
<b>Power Supply and Output</b>		
Voltage	48-230 $\sim$ , 50/60 Hz or 48-230 $\equiv$ (Terminals 1/2)	24 $\equiv$ (20 to 30 $\equiv$ ) Option: 12 $\equiv$ (10 to 14 $\equiv$ )
Power Consumption	200mA max.	$\leq$ 50 mA max. (at 24 $\equiv$ and 20°C)
Output	Break or make contact, switch selected (for relay contact limits see 'Electrical Connection').	Passive current output 4 - 20 mA (20 to 30 $\equiv$ ) Max. load: 500 Ohms for 24 $\equiv$ 200 Ohms for 12 $\equiv$
Functional Earth FE (Protective)	<10 Ohms Protective earthing obligatory in connection chamber	<10 Ohms
<b>Full-Scale Range "v" Adjustable</b>	Reference velocity between 0.1 and 9.9 m/s (0.3 and 32.5 ft/s)	Full scale 1, 2, 3, 4, 5, 6, 7 or 8 m/s (3.3, 6.6, 9.9, 13.1, 16.4, 19.6, 22.9 or 26.2 ft/s)
<b>Time Constant</b>	choice of 5, 8 or 10 seconds	5 seconds fixed
<b>Operating Data</b>	Largely homogeneous liquids, pastes and slurries, also with solids content	
Liquid	$\geq$ 20 $\mu$ s/cm ( $\mu$ mho/cm)	
Electrical Conductivity	$\leq$ 25 bar (360 psi)	
Operating Pressure	- 25 to + 150° C (-13 to +302°F)	
Process Temperature	- 25 to + 60° C (-13 to +140°F)	
Ambient Temperature		
<b>Installation</b>	All DN's $\geq$ 50 mm (2")	
Nominal Pipe Diameter (DN)	Threaded G1A (R 1")	
Connection Socket	10 x DN / 5 x DN	
Inlet / Outlet Run		
<b>Protection Category</b>	IP 66, Equivalent to NEMA 4 IP66 or IP68	
<b>Local Display</b>	Flashing LED (DWM 1000 only)	
<b>Cable Entry</b>	PG 13,5 (1/2" NPT) for external cable diameters of 6 to 12mm (0.24" 0.47")	
<b>Power Terminals</b>	Max. wire diameter 1,5 mm <sup>2</sup> (16 AWG)	
<b>Error Limits</b>	<b>SP</b> = Switching Point	<b>MV</b> = Measured Value
<b>v &gt; 1 m/s (3.3 ft/s)</b>	$\pm$ 5% of SP	$\pm$ 2% of MV
<b>v &lt; 1 m/s (3.3 ft/s)</b>	$\pm$ 3 cm/s (1.2 inches/s) + 2% of SP	$\pm$ 2 cm/s (0.79 inches/s)
<b>Reproducibility</b>	1% of Switching Point	1% of Measured Value
<b>Hysteresis</b>	8% when decreasing velocity	8% when decreasing velocity
<b>Interchangeability</b>	In the case of a breakdown we advice a complete replacement of the DWM unit in order to preserve the accuracy of the results. A change in the electronic threshold can induce errors of <10%	
<b>Ex Versions Coding (on side label)</b>		Ex n R II T6...T3 X Zone 2 (according to IEC 79-15)
<b>Materials:</b>	CrNi - Stainless Steel 1.4435 (SS 316 L - AISI) + ceramic insulation (zirconium oxide)	
<u>Probe</u>	Platinum	
<u>Electrode</u>	Diecast aluminium with epoxy finish	
<u>Housing</u>	Stainless Steel 1.4435 (SS 316 L - AISI)	
<u>Connection Socket</u>	Nickel plated brass	
<u>Cable Entry Gland</u>		
<u>Gaskets</u>	Buna N	
<u>Housing Cover</u>	Viton	
<u>Ceramic Seal</u>	Klingerit (without asbestos)	
<u>Connection Socket</u>		

**Austria**

Krohne Ges.m.b.H.  
Wagramerstrasse 81  
Donauzentrum  
A-1220 Wien  
Tel. (01) 2 03 45 32  
2 03 23 28  
Telex : 115 864  
Fax : (01) 2 03 47 78

**Germany**

Krohne Meßtechnik  
GmbH & Co.KG  
Postfach 10 08 62  
D-47008 Duisburg  
Ludwig-Krohne-Strasse 5  
D-47058 Duisburg  
Tel. (0203) 301-0  
Telex : 17 203 301  
Fax : (02 03) 301 389

**Netherlands**

Krohne Persenaire  
Kerkeplaat 12  
3313 LC Dordrecht  
oder  
Postbus 110  
3300 AC Dordrecht  
Telefon : (078) 630 6200  
Telefax : (078) 630 6234

**Belgium**

Krohne Belgium N.V.  
Brusselstraat 320  
B - 1702 Groot Bijgaarden  
Tel. (02) 4 66 00 10  
Fax : (02) 4 66 08 00

**Great-Britain**

Krohne Measurement & Control Ltd.  
Rutherford Drive  
Park Farm Industrial Estate  
Wellingborough, Northants NN8 6AE  
Tel. (0 19 33) 40 85 00  
Fax : (0 19 33) 40 85 01

**South Africa**

Krohne (Pty) Ltd  
P.O. Box 2078  
1685 Halfway House  
557 15th Road  
Midrand  
Tel. (0 11) 3 14 13 51  
Fax : (0 11) 3 14 11 37

**Representations**

Algeria  
Argentina  
Australia  
Brazil  
Bulgaria  
Cameroon  
Canada  
Chile  
Czech Republic  
Denmark  
Ecuador  
Egypt  
Finland  
Greece  
Hungaria  
Indonesia  
Iran  
Ireland  
Israël  
Ivory Coast  
Jordan  
Kuwait  
Malaysia  
Mauritius  
Mexico  
Morocco  
Nigeria  
Norway  
Oman  
Pakistan  
Poland  
Portugal  
Quatar  
Saudi Arabia  
Senegal  
Singapore  
Sweden  
Taiwan  
Thailand  
The Philippines  
Tunisia  
Turkey  
U.A.E.  
Venezuela

**China**

Kanex Krohne Beijing  
Rm 830, Old Bldg, Xiyuan Hotel  
Xi Jiao Er Li Gou Beijing, P.R. of China  
Tel. 00 86-(0) 10-8313388 Ex 5830  
Telex : 22 831 XYHCN Ex 5830  
Fax : 00 86-(0) 10-68310661

**Hong Kong**

Kanex Krohne Hong Kong Co.  
Room 112, Tung Shun King Office  
Center, 1st floor  
N° 22 Chi Kiang Street  
Tokwawan, Kowloon, Hong Kong  
Tel. (852) 233 397 88  
or 236 301 11  
Fax : (852) 277 437 26

**Spain**

Instrumentacion Industrial  
Krohne Iberia, S.r.l.  
Poligono Industrial Alcala I  
Calle El Escorial, nave 206  
E-28805 Alcala de Henares  
Madrid  
Tel. (9) 18 83 21 52  
Fax : (9) 18 83 48 54

**China**

Kanex Krohne Shanghai  
Room 928B, Jin Du Mansion  
277 Wu Xing Road  
Shanghai 200 233, P.R. of China  
Tel. 0086-(0) 21-64674949  
or 64675353  
Fax : 0086-(0) 21-64673399  
Cellphone : 0086-(0) 139 1721320

**India**

Krohne Marschall Pvt. Ltd  
A-34/35, MIDC  
Industrial Estate  
"H"-Block, Pimpri  
Poona 411018  
Tel. (02 12) 77 74 72  
Telex : 0146-323 FSON  
0146-221 JNMS  
Fax : (02 12) 77 70 49

**Switzerland**

Krohne AG  
Uferstrasse 90  
Postfach 568  
CH-4019 Basel  
Tel. (0 61) 6 31 11 22  
Telex : 963 452  
Fax : (0 61) 6 31 14 18

**CIS + Baltic States**

Kanex Krohne Engineering AG  
Malay Bronnay, 26/3  
103001 Moscow / Russia  
Post Box 23  
177071 Moscow / Russia  
Tel. 007-095-203 0095  
ou 203 0249  
Fax : 007-095-299 8219

**Italy**

Krohne Italia Srl  
Via V. Monti 75  
I-20145 Milano  
Tel. (02) 43 00 661  
Fax : (02) 43 00 6666

**USA**

Krohne America Inc.  
7 Dearborn Road  
Peabody, MA 01960  
Tél. (508) 535 60 60  
(1.800.356.9464)  
Téléfax : (508) 535 17 20  
PC Téléfax : (508) 535 3851  
Internet address : krohne shore.net

**France**

KROHNE S.A.  
Usine des Ors - B.P. 98  
26103 Romans Cedex  
Tel. 33-04.75.05.44.00  
Telex 345 153  
Fax. 33-04.75.05.00.48

**Japan**

Krohne Liaison Office  
497-17 Kawakami  
Totsuka  
Yokohama 244  
Tel. 81-45-8-26 30 34  
Fax : 81-45-8-26 57 35