

Installation and operating instructions

C95 CI

Digital panel meter (6 digits)
Valid for instruments with version v.01

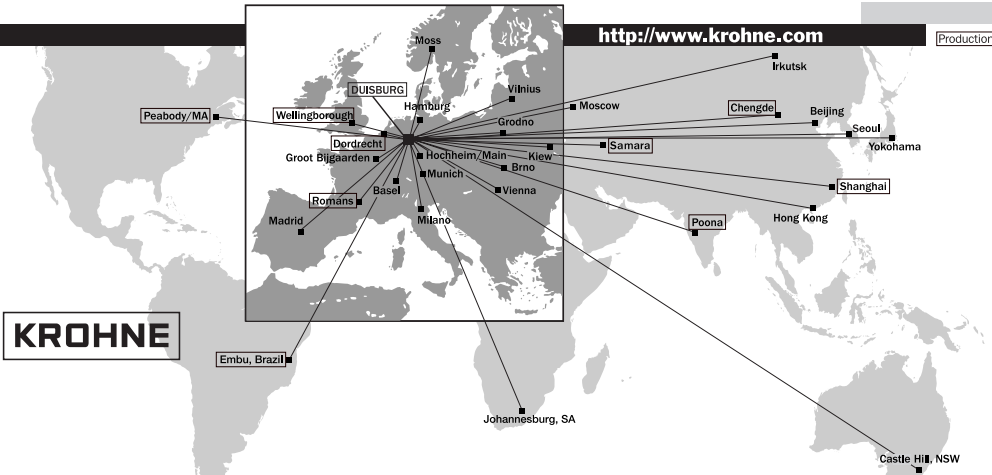
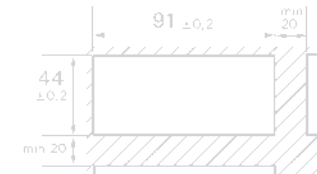
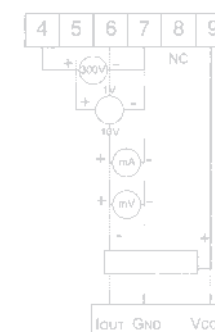
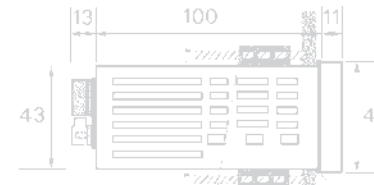

KROHNE

Australia
KROHNE Australia Pty Ltd.
Unit 19 No. 9, Hudson Ave.
Castle Hill 2154, NSW
TEL: +61(0)2-98948711
FAX: +61(0)2-98994855
e-mail: krohne@krohne.com.au

Austria
KROHNE Austria Ges.m.b.H.
Modocenterstraße 14
A-1030 Wien
TEL: +43(0)1/203 45 32
FAX: +43(0)1/203 47 78
e-mail: info@krohne.at

Belgium
KROHNE Belgium N.V.
Brusselstraat 320
B-1102 Groot-Bijgaarden
TEL: +32(0)2-4 66 00 10
FAX: +32(0)2-4 66 08 00
e-mail: krohne@krohne.be

Brazil
KROHNE Conaut
Controles Automaticos Ltda.
Estrada Das Águas Espraiadas, 230 C.P. 56
06835 - 080 EMBU - SP
TEL: +55(0)11-4785-2700
FAX: +55(0)11-4785-2768
e-mail: conaut@conaut.com.br

China
KROHNE Measurement Instruments Co. Ltd.
Room 7E, Yi Dian Mansion
746 Zhao Jia Bang Road
Shanghai 200030
TEL: +86(0)21-64677163
FAX: +86(0)21-64677166
Cellphone: +86(0)139 1885890
e-mail: info@krohne-asia.com

CIS
Kanex KROHNE Engineering AG
Business-Centre Planeten, Office 403
ul. Manistskaja 3
109147 Moscow/Russia
TEL: +7(0)095-9117165
FAX: +7(0)095-9117231
e-mail: krohne@td.ru

Czech Republic
KROHNE CZ, spol. s r.o.
Soběšická 156
CZ-63800 Brno
TEL: +420 545 532 111
FAX: +420 545 220 093
e-mail: brno@krohne.cz

France
KROHNE S.A.S.
Usine des Ois
BP 98
F-26 103 Romans Cedex
TEL: +33(0)4-75 05 44 00
FAX: +33(0)4-75 05 00 48
e-mail: info@krohne.fr

Germany
KROHNE Messtechnik
GmbH & Co. KG
Ludwig-Krohne-Straße
D-47058 Duisburg
TEL: +49(0)203-301-0
FAX: +49(0)203-301-389
e-mail: krohne@krohne.de

India
KROHNE Marshall Ltd.
A-34/35, M.I.D.C.
Industrial Area, H-Block,
Pimpri Poona 411018
TEL: +91(0)20-744 20 20
FAX: +91(0)20-744 20 40
e-mail: pcv@vsnl.net

Italy
KROHNE Italia Srl.
Via V. Monti 75
I-20145 Milano
TEL: +39(0)2-4 30 06 61
FAX: +39(0)2-43 00 66 66
e-mail: krohne@krohne.it

Korea
Hankuk KROHNE
2 F, 59B-1
Banghwa-2-Dong
Kangseo-Ku
Seoul
TEL: +82(0)2665-85 23-4
FAX: +82(0)2665-85 25
e-mail: flowtech@unitel.co.kr

Netherlands
KROHNE Altometer
Kerkeplaat 12
NL-3313 LC Dordrecht
TEL: +31(0)78-6306300
FAX: +31(0)78-6306390
e-mail: postmaster@krohne-altometer.nl

KROHNE Nederland B.V.
Kerkeplaat 12
NL-3313 LC Dordrecht
TEL: +31(0)78-6306200
FAX: +31(0)78-6306405
Service Direkt: +31(0)78-6306222
e-mail: info@krohne.nl

Norway
Krohne Instrumentation A.S.
Ekholtsveien 114
NO-1526 Moss
P.O. Box 2178, NO-1521 Moss
TEL: +47(0)69-264860
FAX: +47(0)69-267333
e-mail: postmaster@krohne.no
Internet: www.krohne.no

South Africa
KROHNE Pty. Ltd.
163 New Road
Halfway House Ext. 13
Midrand
TEL: +27(0)11-315-2685
FAX: +27(0)11-805-0531
e-mail: midrand@krohne.co.za

Spain
I.I. KROHNE Iberia, S.r.L.
Poligono Industrial Nilo
Calle Brasil, n.º. 5
E-28806 Alcalá de Henares -Madrid
TEL: +34(0)91-8 83 21 52
FAX: +34(0)91-8 83 48 54
e-mail: krohne@krohne.es

Switzerland
KROHNE AG
KROHNE AG
Ludwig-Krohne-Str.
D-47058 Duisburg
TEL: +49(0)203-301 309
FAX: +49(0)203-301 389
e-mail: export@krohne.de

United Kingdom
KROHNE Ltd.
Rutherford Drive
Park Farm Industrial Estate
Wellingborough,
Northants NN8 6AE, UK
TEL: +44(0)19 33-408 500
FAX: +44(0)19 33-408 501
e-mail: info@krohne.co.uk

USA
KROHNE Inc.
7 Dearborn Road
Peabody, MA 01960
TEL: +1-978-535-6060
FAX: +1-978-535-1720
e-mail: info@krohne.com

Overseas Representatives

- | | |
|-----------------|--------------|
| Algeria | Japan |
| Argentina | Jordan |
| Bulgaria | Kuwait |
| Cameroon | Morocco |
| Canada | Mauritius |
| Chile | Mexico |
| Columbia | New Zealand |
| Croatia | Pakistan |
| Denmark | Poland |
| Ecuador | Portugal |
| Egypt | Saudi Arabia |
| Finland | Senegal |
| French Antilles | Singapore |
| Greece | Slovakia |
| Guinea | Slovenia |
| Hong Kong | Sweden |
| Hungary | Taiwan |
| Indonesia | Thailand |
| Ivory Coast | Turkey |
| Iran | Tunisia |
| Ireland | Venezuela |
| Israel | Yugoslavia |

Other Countries:
KROHNE Messtechnik
GmbH & Co. KG
Ludwig-Krohne-Str.
D-47058 Duisburg
TEL: +49(0)203-301 309
FAX: +49(0)203-301 389
e-mail: export@krohne.de

■ Summary

1 . INTRODUCTION	p2
2 . SPACE REQUIREMENTS	p3
3 . WIRING	p4
4 . PROGRAMMING	p5
4.1 Communication with the instrument	p5
4.2 Orientation through programming	p6
4.3 Main menu	p6
4.4 Programming menu	p6
4.4.1 - Input programming	p7
4.4.2 - Display programming	p7
4.4.3 - Programming of the totalizer	p8
4.4.4 - Programming of the analog output	p8
4.4.5 - Programming of the digital output	p9
4.4.6 - Programming of the LOGIC inputs	p9
4.4.7 - Programming of the relay outputs	p10
4.4.8 - Programming of the safeties	p11
4.4.9 - Programming of the brightness, displays and bargraph	p12
4.4.10 - Programming exit	p13
4.5 Input features and programming limits	p13
4.5.1 - Current input	p13
4.5.2 - Voltage input	p14
4.5.3 - Instant value display	p14
4.5.4 - Totalizer	p15
4.5.5 - Display features	p15
4.5.6 - LOGIC inputs	p16
4.6 Output features and programming limits	p17
4.6.1 - Analog output	p17
4.6.2 - Digital output	p17
4.6.3 - Relay outputs	p17
4.6.4 - Safeties	p18
4.7 Configuration reading	p19

4.8 Access code	p20
4.9 Programming of a new access code	p20
4.10 Functions accessible in the main menu	p20
4.10.1 - Display simulation	p20
4.10.2 - Analog output simulation	p21
4.10.3 - Menu CLEAR : Deleting of recorded alarms	p21
4.10.4 - Menu CLr.tA : Deleting of the recorded tare	p21
5 . FUNCTIONS DIRECT FROM THE DISPLAY	p21
5.1 Functions which require pressing only 1 key	p21
5.1.1 - On the instant value display <i>a / Minimum value display</i> <i>b / Maximum value display</i> <i>c / Erasing of min. and max. values</i>	p21 p21 p21 p22
5.1.2 - On the totalizer display <i>a / Upper part display</i> <i>b / Access to the zero reset menu</i>	p22 p22 p22
5.2 Functions which require pressing several keys	p22
5.2.1 - Display shifting	p22
5.2.2 - Tare setting	p23
5.2.3 - Changing of the displayed value	p23
5.2.4 - Direct measure visualisation	p23
5.2.5 - Visualisation and setting of alarm setpoints	p23
6 . ERROR MESSAGES	p23
7 . GENERAL WARRANTY TERMS	p24
8 . LEXIQUE	p24
9 . ANNEXE : MODBUS	p28
9.1 Table of Modbus addresses	p28
9.2 Description of born Modbus functions	p29
9.3 Reading in double integer format	p29
9.4 CRC16 calculation algorithm	p30

1. INTRODUCTION

The **C95 CI** is a totalling digital panel meter. The totalling function allows converting any instant value, after integration, into a cumulated magnitude.

It can be connected to a flowmeter to display the instant flow and the cumulated volume or weight, and also to a converter, for instance a power converter to display the instant power and the energy consumption of an installation.

General features

- Instant value display on 5 digits (14mm) with scale factor adjusting from -99 999 to 99 999
 - Cumulated value display on a 6 digit counter (14mm) associated with a second overstepping counter, allows totalling from -99 999 999 to +999 999 999
 - Totalizer memory saved in case of power supply cut
 - Programming of the integration time (sec, min, hours) and of a conversion coefficient (from 0,0001 to 999999)
 - A bargraph allows a quick evaluation either of the instant value or the cumulated value, and can also be used as indicator for various functions (overstepping, LOGIC input, RS, etc...)
- Input :
- Direct current or voltage, bidirectionnal
 $\pm 100\text{mV}$, $\pm 1\text{V}$, $\pm 10\text{V}$, $\pm 300\text{V}$, $\pm 20\text{mA}$
 - Measurable scale overstepping from -5% to +5%
 - Input impedance $\geq 1\text{M}\Omega$ for voltage inputs
drop 0.9V max for the current input
 - Enlarging effect possible
 - Linear input with or without square root extraction and special curve on 20 pt (programmable in X and in Y).
 - Supply for 2 or 3 wire sensor for the current input : 26 VDC ($\pm 15\%$)
100mA protected from short-circuits.

• Transfer :

- Accuracy 0.05% of full scale at 25°C
- Thermic drift $< 150 \text{ ppm} / ^\circ\text{C}$
- Sampling time : 100ms
- Filtering : Programmable integration time (10 coefficients)
- Common mode rejection rate : 130 dB
- Serial mode rejection rate : 70 dB 50/60 Hz
- Insulation : Input / Power supply : 2.5kV 50 Hz 1 min
Input / Output : 2.5kV eff. 50 Hz 1 min

AVAILABLE OPTIONS : (specify on order)

Insulated analog output : A

Programmable on the instant or cumulated value
Active current output
Programmable scale ratio with enlarging effect.

Relay output 2 relays (R)

Programmable :
- As Pulse output with adjusting of the pulse weight
(-10 000 to +10 000) and of its duration
(100, 200 or 400 ms)
- In mode alarm on the instant or cumulated value
Mode setpoint or window.
Recording of alarms.
Time delay and hysteresis adjustable on each setpoint.
Alarm messages

Insulated digital output : N

RS 485 2 wire, protocole MODBUS-JBUS.

LOGIC input 2 insulated LOGIC inputs with programmable functions

Several types of totalizer zero reset
Integration stop and start
Display blocking
Display switching (instant value / totalizer)
Function tare,
min. and max. zero reset

- **Power supply** : (specify on order)

2 Versions : High Voltage or Low Voltage

High Voltage : 90...270 VAC and 88 ...350 VDC 50/60/400 Hz

Low Voltage : 20...53 VAC and 20...75 VDC 50/60/400 Hz

- **Power draw** : 7 W max. 10 VA max.

- **Complies** with standards EN 50081-2 on rejections and EN 50082-2; on immunity (in industrial environment)

EN 61000-4-2 level 3, EN 61000-4-3 level 3,

EN 61000-4-4 level 4, EN 61000-4-6 level 3.

CE marking according to Directive EMC 89-336

2. SPACE REQUIREMENTS

Case dimensions : (with terminals)

96 x 48 x 124 mm

Fitting panel
max. thickness 30

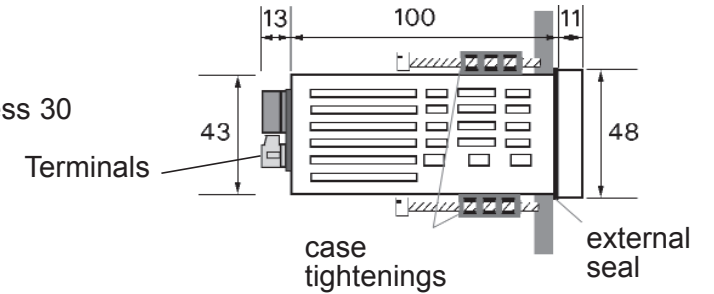

Panel mounting

cut out 44 x 91 mm

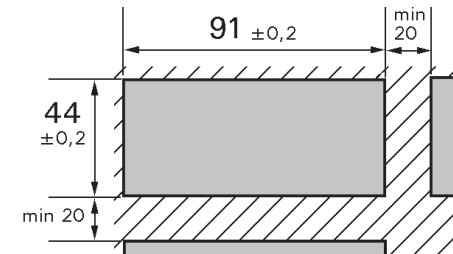

Protection :

Front face : IP 65

Case : IP20

Terminals : IP 20

Case :

Self-extinguishing casing of
black UL 94 V0 ABS.

Connectors plug-off connectors on
rear face for screwed connections
(2.5mm², flexible or rigid)

Display : (14 mm)
Electroluminescent red (green optional)
4 alarm Leds
bargraph : 16 leds

3. WIRING

INPUTS

PROCESS

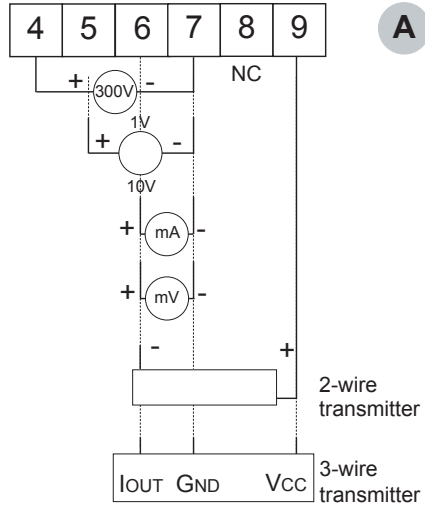

LOGIC INPUTS (optional)

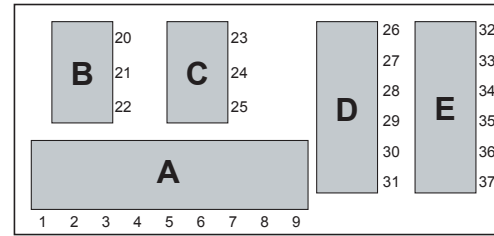
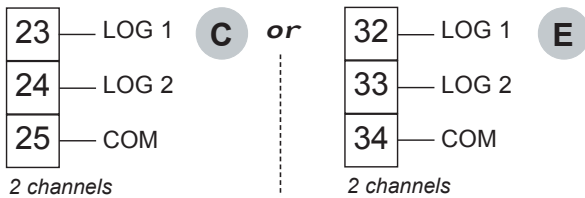

Location of terminals
(view of case rear side)

OUTPUTS (optional)

ACTIVE CURRENT

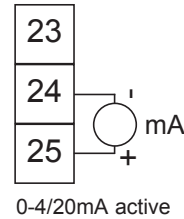

2 RELAYS

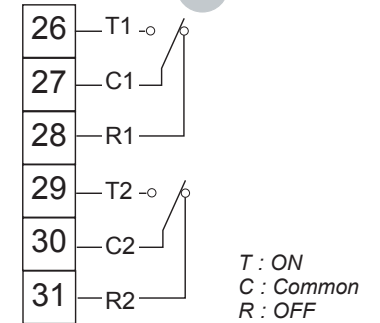

DIGITAL

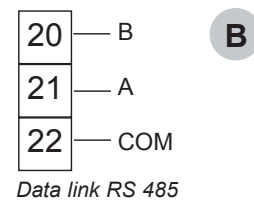

POWER SUPPLY

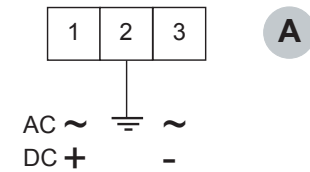

4. PROGRAMMING

4.1 Communication with the instrument

Functions available from the instant measure :

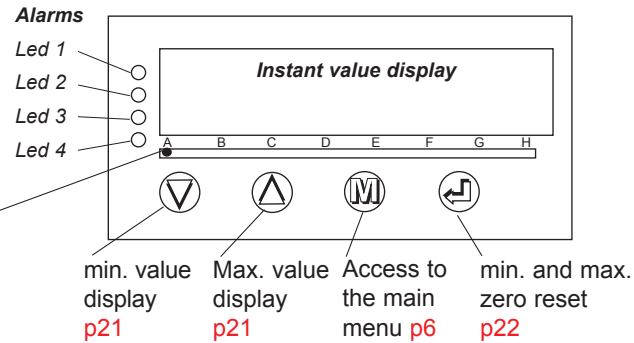

The Led under marking A blinks to indicate that the displayed value is the instant value.

Functions available from the totalizer :

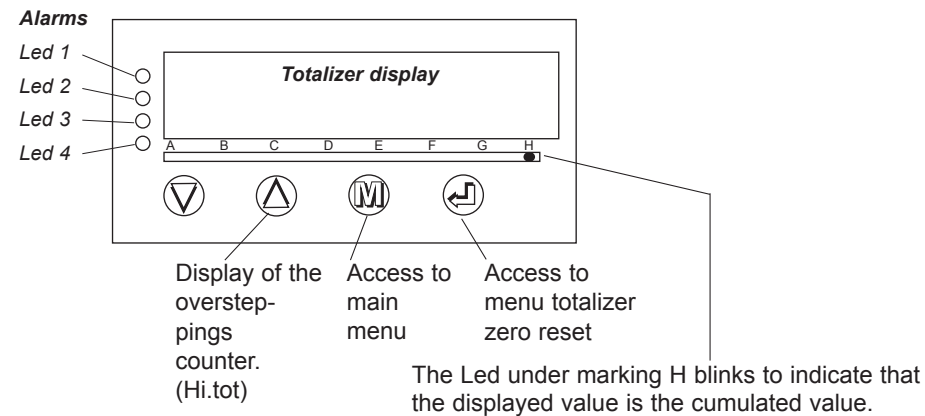

Further functions can be reached by pressing several keys :

- + Switching from instant value display to cumulated value display and vice-versa;
- + Direct measure visualisation; (see p24)
- + Visualisation and setting of alarm setpoints; (see p24)

Only on the instant value display.

- + Tare setting; (see p23)
- + Down scale display setting; (see p23)
- + Full scale display setting; (see p23)

Reading convention :

- Move through main menu
- Return to previous menu
- Blinking display : awaiting validation or setting
- Alternate information display

Entering of a parameter :

- | | | |
|--|---|---|
| | First start by increasing or decreasing the 1st digit and the sign : from -9 to +9. | & |
| | The 2nd from 0 to 9. | Between each entering, validate the cipher with key |
| | The 3rd from 0 to 9. | |
| | The 4th from 0 to 9. | |
| | The 5th from 0 to 9. | |
| | | |
- Note :** The totalizer parameters are entered on 6 digits.

4.2 Orientation through programming

Dialogue is ensured by the 4 keys located on the front face.

- | | | | |
|--|--|--|--|
| | | | |
| Move through menus : downwards, or decreasing of the displayed value | Move through menus : upwards, or increasing of the displayed value | Exit from a sub-menu to access next menu / access to the programming exit menu | Validation of the displayed parameter, or access to a sub-menu |



Note : In mode programming, the instrument will automatically resume measuring with the previous configuration if no key is pressed during 1min.

4.3 Main menu

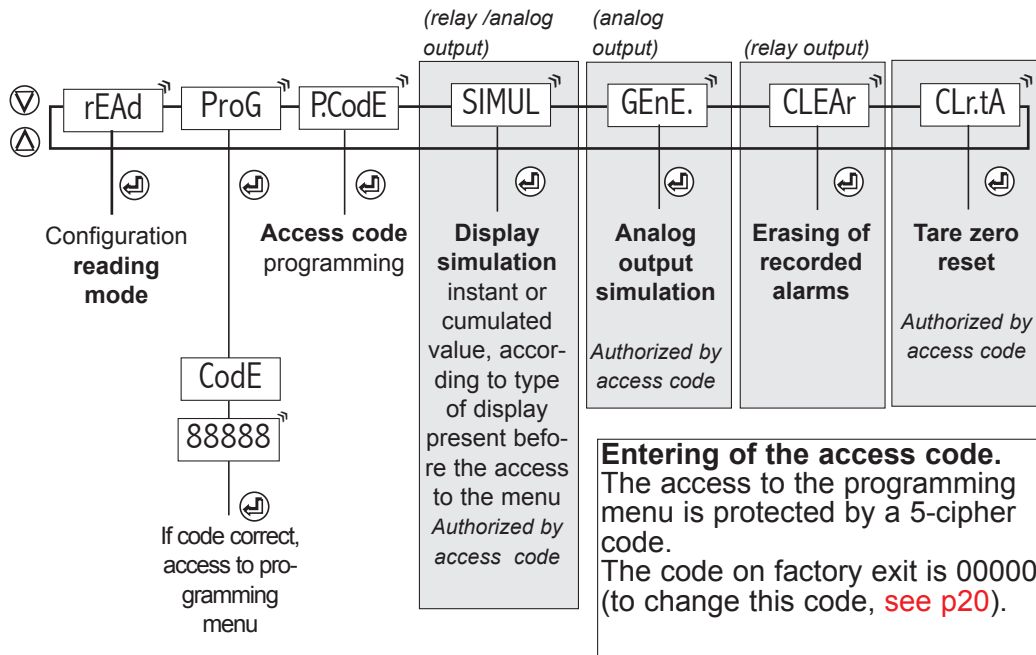
 menu
 scroll
 vertical move





4.4 Programming menu (according to options)

	InPut	Access to input programming	p7
	dISPL.	Access to the display factor programming (instant value)	p7
	totAl.	After programming the totalizer	p8
	OUt.MA	Access to the analog output programming (option analog output)	p8
	JbuS	Access to the communication parameters (option digital output)	p9
	tor	Access to the programming of the LOGIC inputs (option LOGIC inputs)	p9
	rELAY	Access to the programming of the relays (2 relays) (option relay output)	p10
	SECU	Access to the programming of the output, the relays, in case of self-diagnosis and/or sensor rupture, and access to disconnecting the sensor rupture (option analog output or relays)	p11
	Pr.diS	Access to the display programming : Bargraph, display brightness	p12
	SAvE	Access to the programming exit menu with or without configuration saving	p13

Note :

⇒ Press  to reach menu **SAvE**

⇒ In mode programming, the instrument will automatically resume measuring with the former configuration if no key is pressed during 1min.

 Move through menus / choice

 Menu exit / access	 Upwards move / increase
 Downwards move / decrease	 Validation / Vertical move

4.4.1 Input programming

InPut

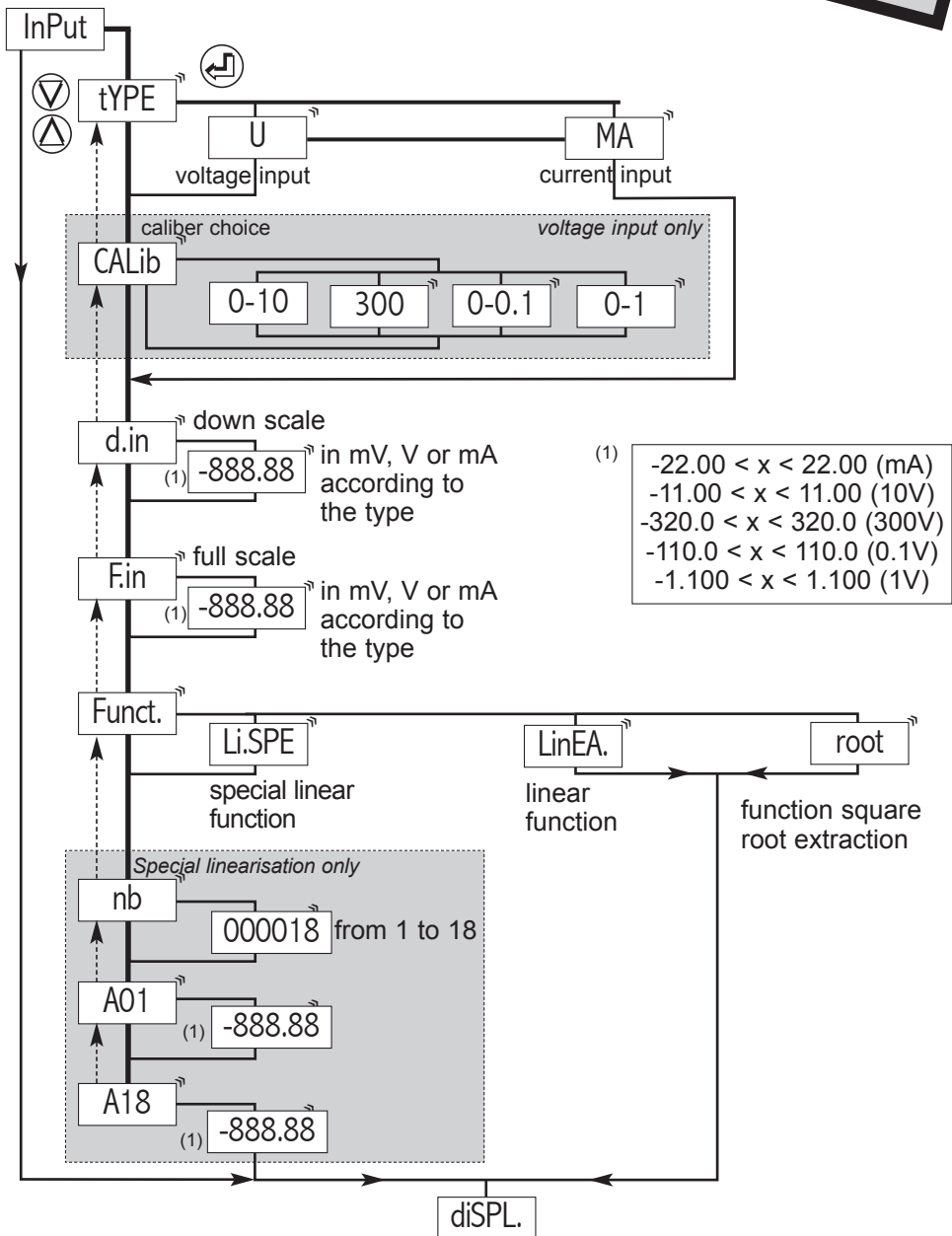

Note :
Press key to reach menu diSPL.

4.4.2 Display programming (instant value)

diSPL.

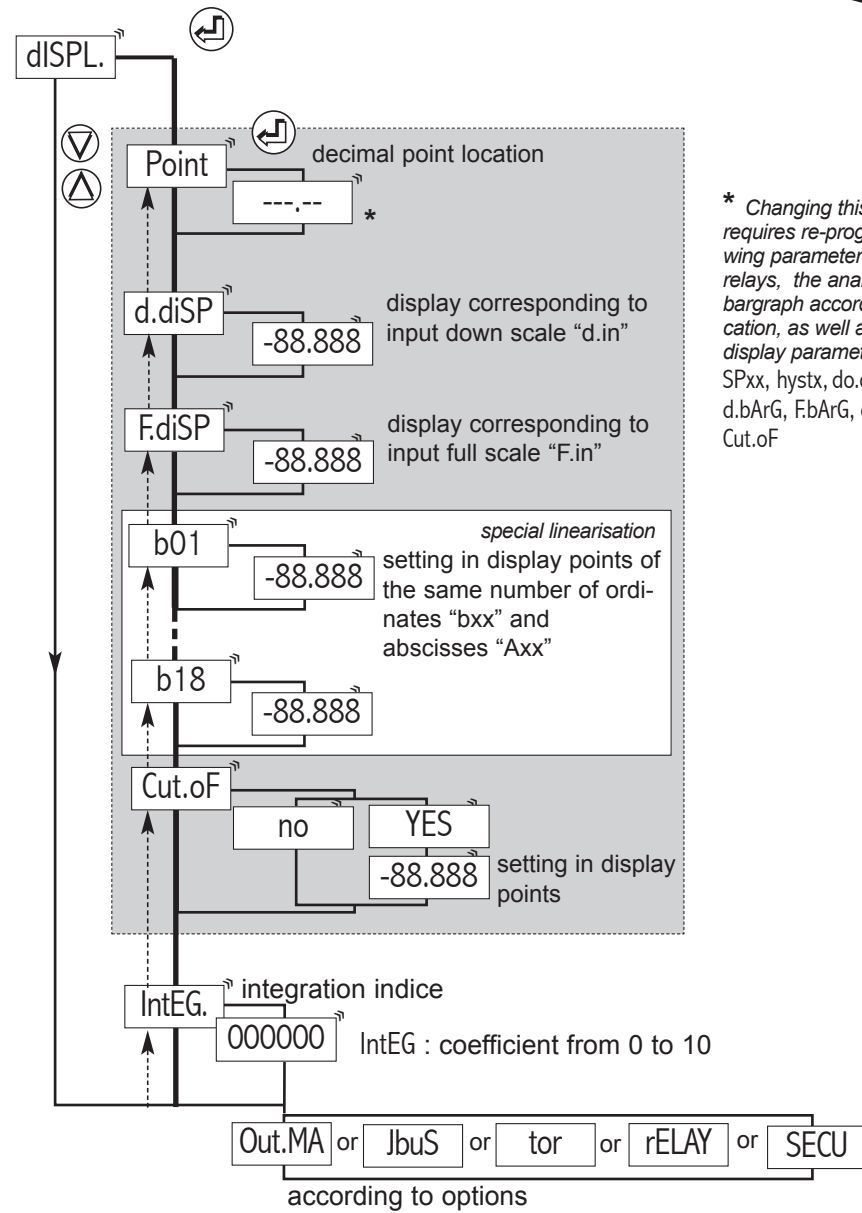

* Changing this parameter requires re-programming following parameters related to the relays, the analog output, the bargraph according to their dedication, as well as following display parameters :
SPxx, hystx, do.diS, Fo.diS
d.bArG, F.bArG, d.diSP, F.diSP, bxx, Cut.oF

4.4.3 Totalizer programming

TotAl

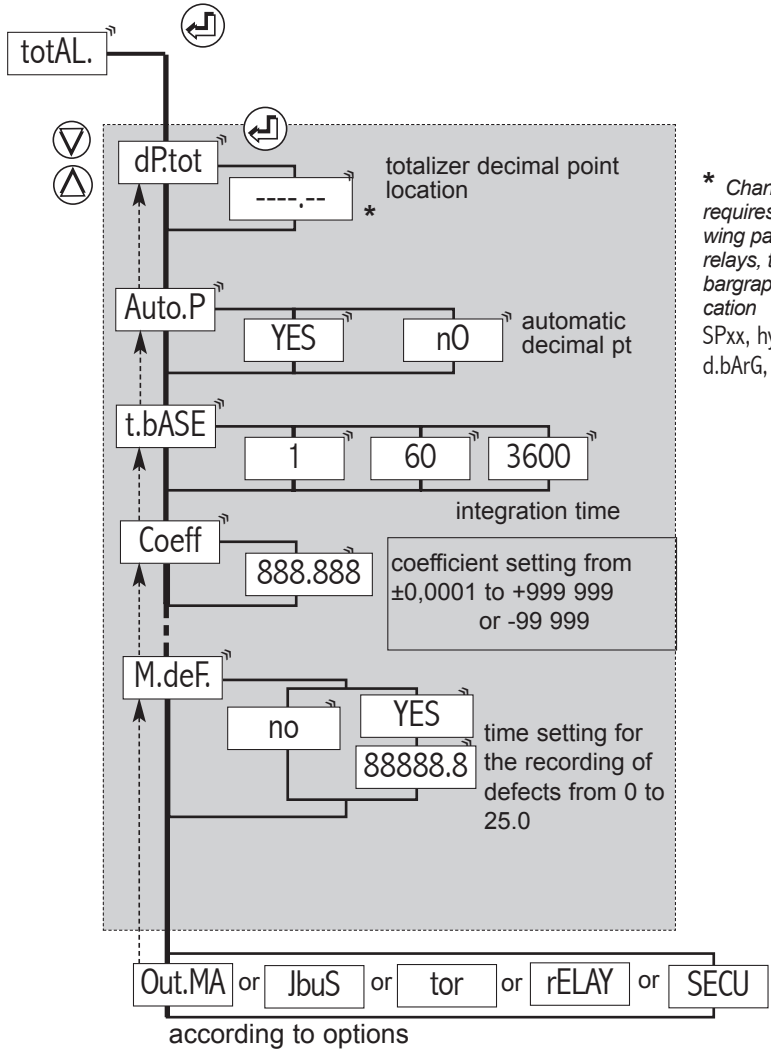

* Changing this parameter requires re-programming following parameters related to the relays, the analog output, the bargraph according to their dedication
 SPxx, hystx, do.diS, Fo.diS
 d.bArG, F.bArG,

4.4.4 Analog output programming

Option analog output

Out.MA

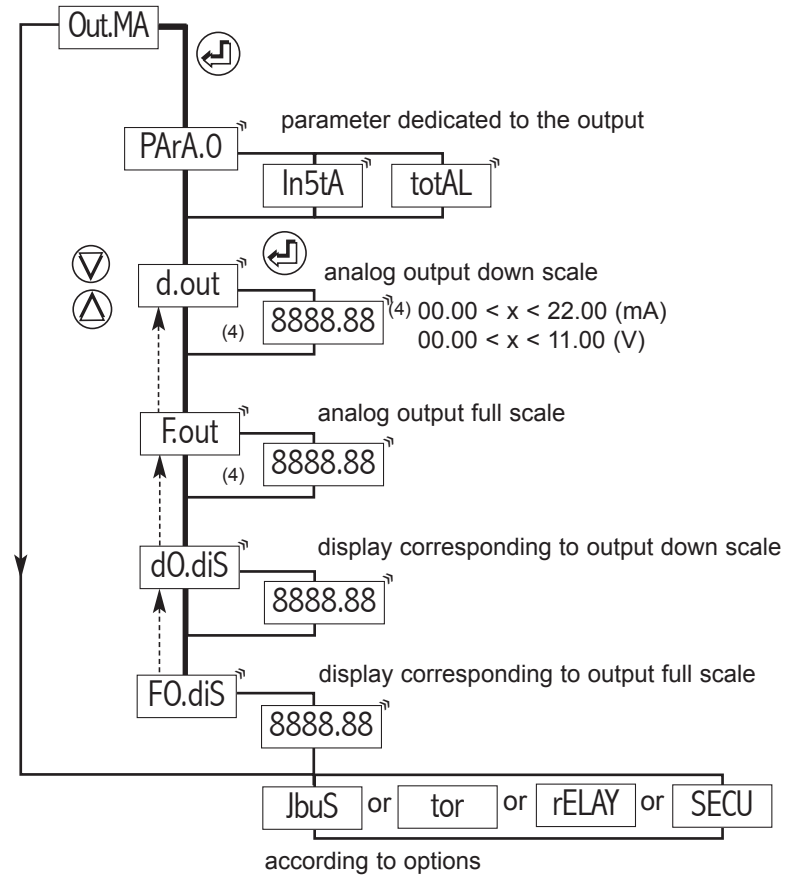

See also output features p17

Note :

Press to go on to next menu Move through menus / choice

	Menu exit / access		Upwards move / increase
	Downwards move / decrease		Validation / vertical move

4.4.5 Programming of the digital output

Option digital output

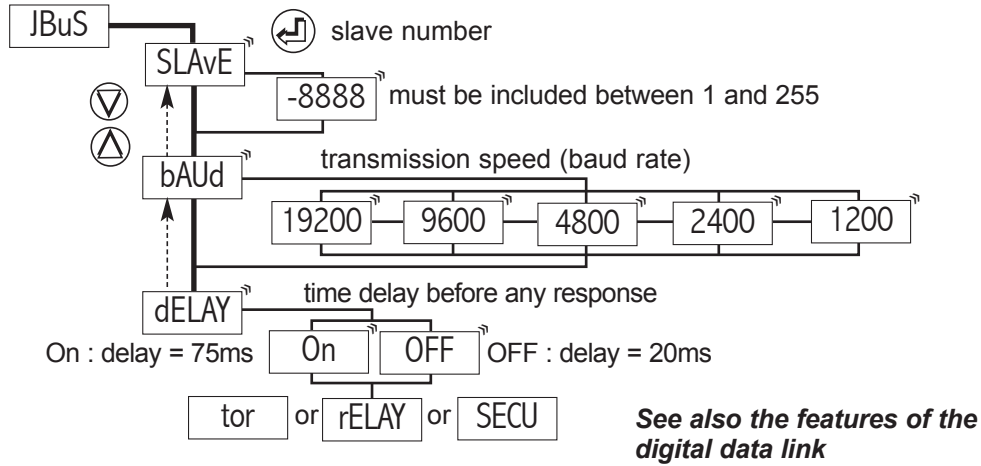
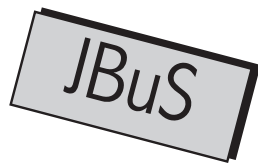

4.4.6 Programming of the LOGIC inputs

Option LOGIC inputs

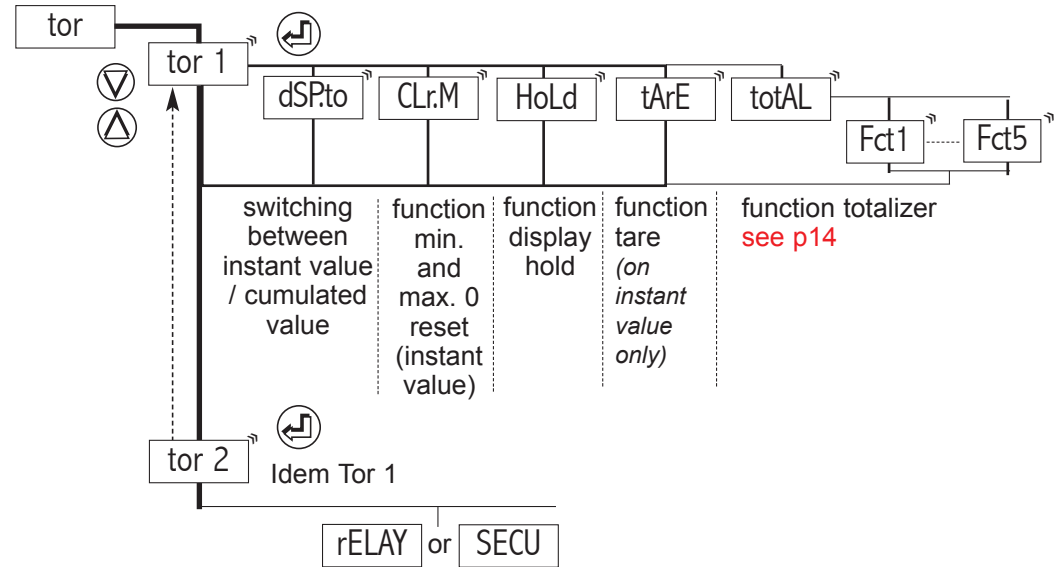

	Menu exit / access		Upwards move / increase
	Downwards move / decrease		Validation / vertical move

4.4.7 Programming of the relay outputs

Option output 2 relays

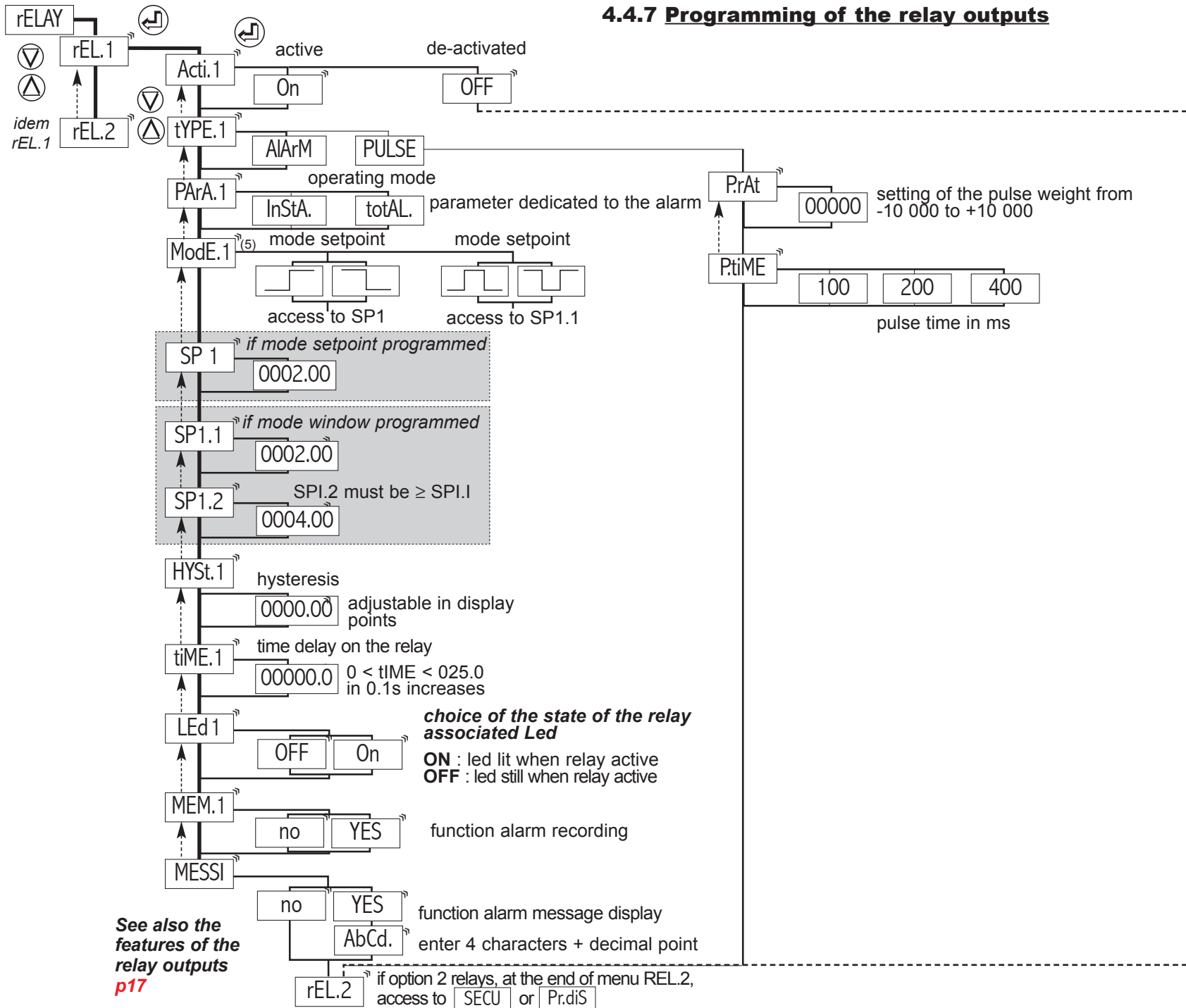

4.4.8 Programming of the safeties

SECU

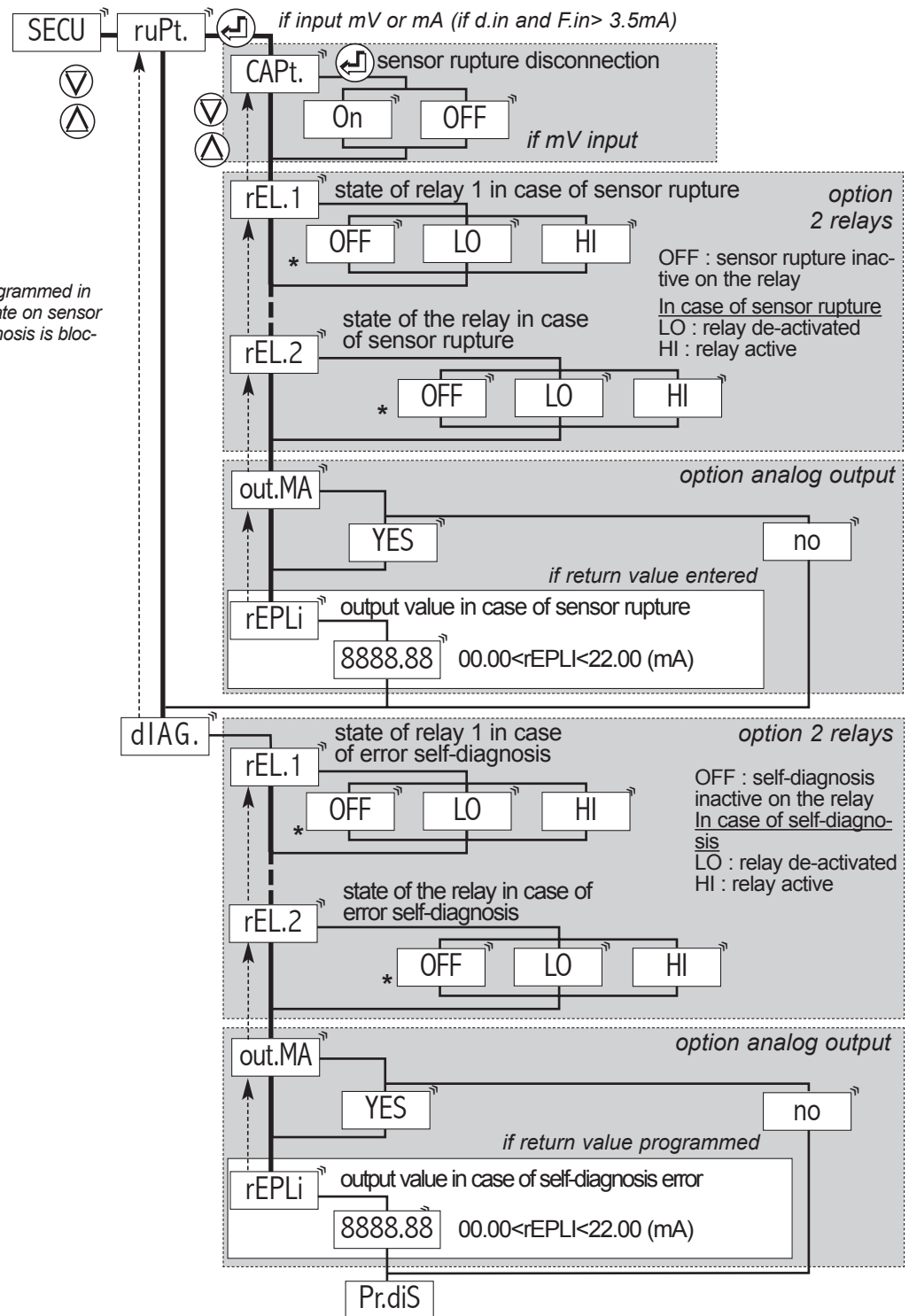

* If the relay is programmed in mode pulses, its state on sensor rupture or self-diagnosis is blocked on OFF.

See also the safety features p18

4.4.9 Programming of the brightness, the displays and the bargraph

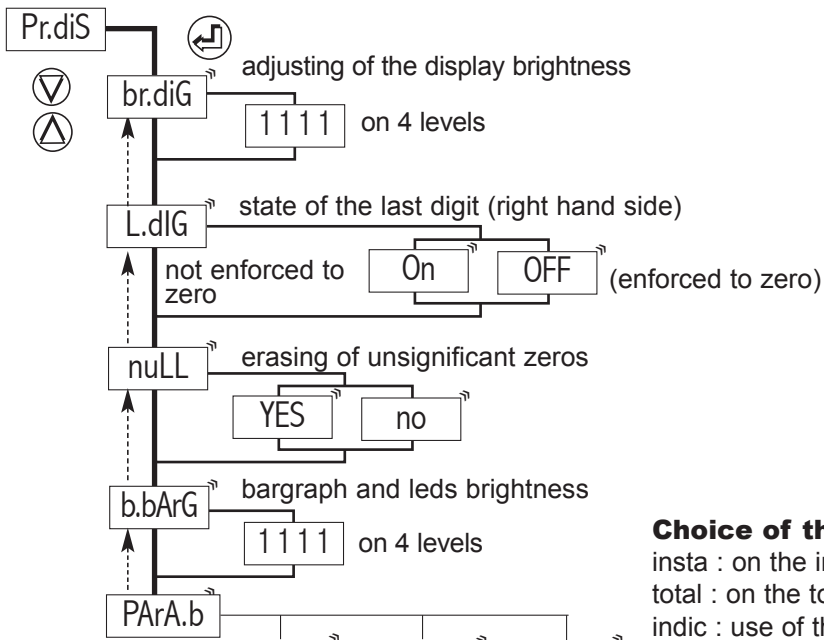

Choice of the bargraph operating mode

insta : on the instant value
 total : on the totalizer
 indic : use of the bargraph to indicate some functions

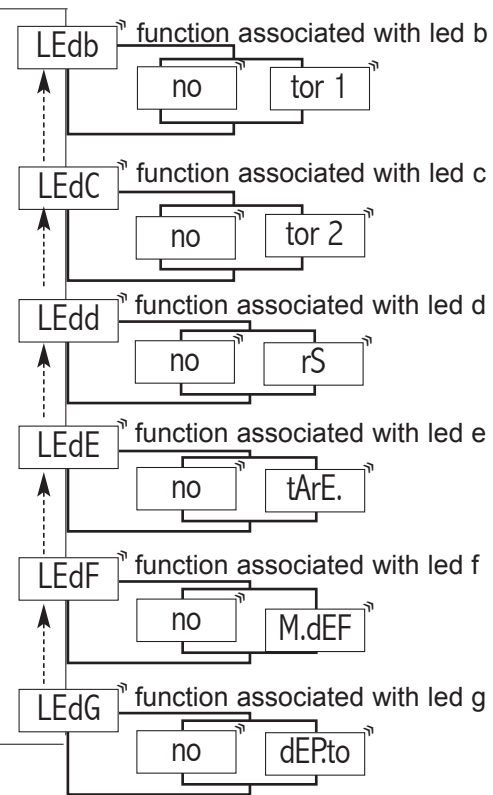
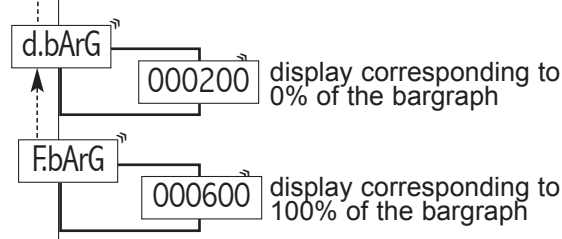
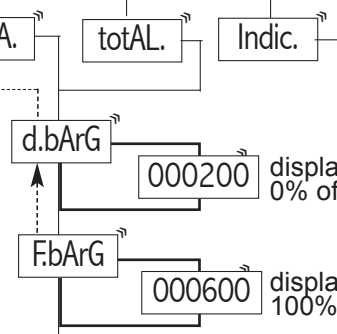

no : no dedication
tor 1 : led b dedicated to the indication of logic input 1
tor 2 : led c dedicated to the indication of logic input 2
rS : led lit in case of RS transmission
tArE. : led lit if a tare has been entered
M.dEF : led lit in case an error has been recorded
dEP.to : led lit if overstepping on the 1st totalizer >999 999 or < -99 999 (Hi.tot ≠ 0)

SAvE

See also the display features **p15**

4.4.10 Programming exit with or without saving

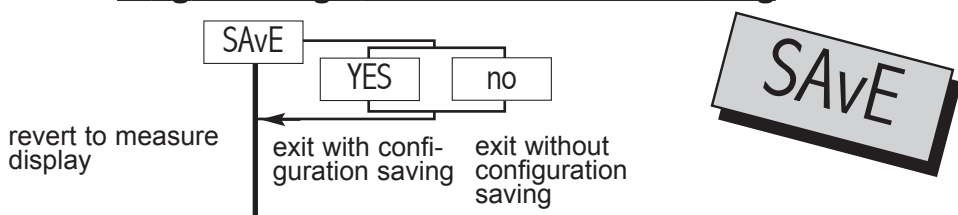

Note : Exit from mode programming with configuration saving (SAvE, YES) will automatically reset to zero the tare, the min. and max. and the recording of alarms, as well as the pulse output buffers.

In case of modification of the decimal point location of the instant value or of the totalizer, the instrument will propose after SAvE YES all the decimal point related parameters which have not been modified.

A SAvE YES will not reset the totalizer to zero. If its parameters have been changed it will have to be reset to zero, in order to avoid an incoherent counting (see p22).

4.5 Input features and programming limits

4.5.1 Current input

MA

• Linear :

Features

Caliber	Display resolution	Input stage resolution	Accuracy
from -20 to +20mA	± 1 digit	16 bits	0.05% of MR

Measurable input limits : -22 to 22 mA

• Unlinear :

Square root extraction

root

Note : The function square root extraction tends to amplify the input signal background noise on getting near zero.

To avoid the ripples caused by this noise, just programme a cut-off value (in display points), see p14.

Special linearisation :

Li.SPE

For specific applications such as volume measurements, the meter can memorise an unlinear curve programmable in X and in Y.

The curve resulting from your equation can be replaced by a series of linear segments, with a maximum of 20 points (19 segments).

Note : The values of the abscises (x) have to go increasing d.in < value of A01 < value of A02... < F.in.

Example :

Say a layed cylindric tank, 1 meter high (h) and 1 meter long (l). A linear 0-20 mA sensor measures the height of the liquid surface line :

Meter input : height h

0 meter -> 0 mA (empty tank)

1 meter -> 20 mA (full tank)

with $\cos \beta/2 = (R - h) / R$

$\sin \beta/2 = C/2R$

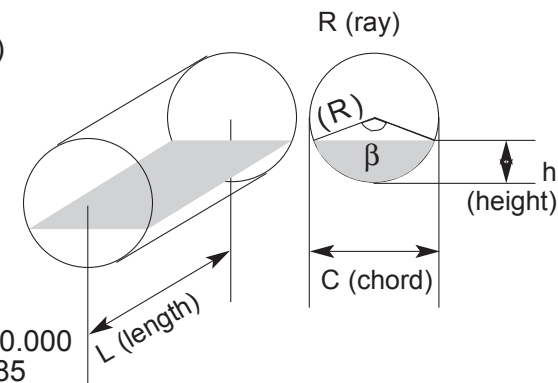

Meter display :

Empty tank volume d.diSP = 0.000

Full tank volume F.diSP = 0.785

$$\text{Volume} = L [\pi R^2 \beta/360 - C(R-h)/2]$$

Hence a curve of 10 equally long segments :

Etendue de mesure / nr of segments = 20mA/10 = 2mA length of the segment. For 10 segments nb = 9 (11 points to be programmed, including d.in and F.in).

Input mA	Height m	Degree	Chord m	Volume m ³	Outps. in mA
d.in 0	0.0	0.00	0.00	d.diSP 0.000	00.00
A01 2	0.1	73.74	0.60	B01 0.041	01.04
A02 4	0.2	106.26	0.80	B02 0.112	02.85
A03 6	0.3	132.84	0.92	B03 0.198	05.04
A04 8	0.4	156.93	0.98	B04 0.293	07.47
A05 10	0.5	180.00	1.00	B05 0.393	10.00
A06 12	0.6	203.07	0.98	B06 0.492	12.54
A07 14	0.7	227.16	0.92	B07 0.587	14.96
A08 16	0.8	253.74	0.70	B08 0.674	17.17
A09 18	0.9	286.76	0.60	B09 0.745	18.98
F.in 20	1.0	360.00	0.00	F.diSP 0.785	20.00

Programming :

d.in = 0 mA F.in = 20 mA

nb = 9

d.disp = 0,000 m³ F.disp = 0,785 m³

Programming from A01 to A09 and from B01 to B09 according to table.

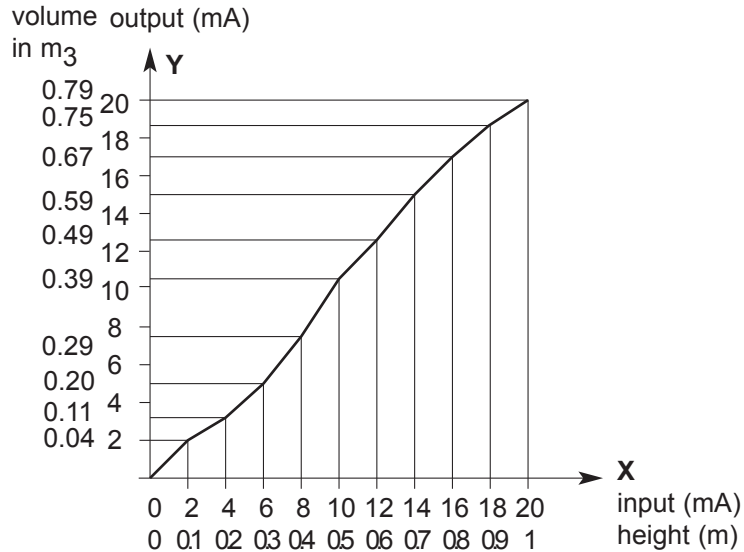

4.5.2 Voltage input

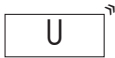

• **Linear :** Features

Caliber	Display resolution	Input stage resolution	Accuracy
-100 to +100 mV -1 to + 1 V -10 to +10 V -300 to 300 V	± 1 digit	16 bits	0.05% of MR

Measurable limits : -5% to +5%

Example for caliber 1V : -1.1V to +1.1V

• **Nonlinear :** (see p13)

4.5.3 Instant value display :

Point Decimal point location for the instant value display (4 decimals maximum).

d.diSP Display corresponding to input down scale

F.diSP Display corresponding to input full scale

bXX Setting in display points of the ordinate for point Axx for a special curve input (see unlinear input)

Cut.oF Expressed in display points.

- If display full scale > display down scale and if display ≤ cut off value, then it is maintained at down scale.
- If display full scale < display down scale and if display ≥ cut off value, then it is maintained at down scale.

• **Response time :**

intEG Digital filtering integration indice :

Programmable from 0 to 10; to be used in case of unsteady input.

intEG	0	1	2	3	4	5
Typical response time at 90%	120 ms	400 ms	600 ms	1 s	1.4 s	2 s
		6	7	8	9	10
	3 s	5 s	7.5 s	10 s	15 s	

2 cycle times, i.e. 240 ms must be added to obtain the maximum response time.

Note : For the analog output response time, add 40ms to the values shown in the table.

For the relays : add the time delay programmed on the alarms.

4.5.4 Totalizer

Totalizer decimal point location
(4 decimal maximum)

Fix decimal point

Automatic decimal point

Decimal point : The totalizer is displayed with a maximum of decimals, and the decimal point will move as the total increases, until the number of decimals programmed in Dp.tot is reached

eg. : programming of the decimal point = --. on starting the totalizer indicates 00.0000. When it reaches 99.9999 it will indicate 100.000, and then 1000.00.

Integration time basis

: 1 sec : 60 sec : 3600 sec

Conversion coefficient : coefficient to be applied on the instant value to calculate the cumulated value, adjustable from ± 0.0001 to 999 999 or -99 999.

Eg. : if the instant value represents m^3 and you want to total up liters, the coefficient will be equal to 1000.

Recording of defects.

No recording

Recording of defects (input electrical oversteppings or sensor rupture) if defect present on the input during a time \geq programmed time. Programming of the time from 0 to 25.0 sec, in 0.1 sec. increases.

Display of error messages alternating with the cumulated value if recording. To reset the recording to zero, [see p22](#) .

4.5.5 Display features :

• **Adjusting of the digits brightness**

Lowest brightness Strongest brightness

• **Last digit inhibition** (low weight)

In mode programming, the menu L.dIG allows suppressing of the last digit display, the latter being enforced to 0 if OFF is validated.

• **Erasing of insignificant zeros**

= Suppresses the display of insignificant zeros on the left hand side.

Eg. : Display value 0015

= Display 0015

= Display 15

Eg. : Display value 00.15

= Display 00.15

= Display 0.15

• **Setting of the bargraph brightness**

Lowest brightness Strongest brightness

The brightness level is visualised directly on the bargraph.

Caution : during setting, the bargraph no longer represents measure, including also in mode reading.

Parameter applied to the bargraph

Bargraph on the instant value

Bargraph on the cumulated value

• **Bargraph display factor**

Display corresponding to the still bargraph (0%)

Display corresponding to the fully lit bargraph (100%)

In case of overstepping, the bargraph will start to blink. A sensor rupture is indicated on the bargraph (if dedicated to the instant value) by the lighting of one led out of two.

Bargraph in mode indication

Led marking b

No dedication (led still)

Led lit when logic input 1 is active

LEd C Led marking c
 no No dedication (led still)
 tor2 Led lit when logic input 2 is active

LEdd Led marking d
 no No dedication (led still)
 RS Led lit during answering of the instrument on the RS

LEdE Led marking e
 no No dedication (led still)
 tArE Led lit when a tare has been entered

LEdF Led marking f
 no No dedication (led still)
 M.dEF Led lit if defect recorded

LEdG Led marking g
 no No dedication (led still)
 dEP.to Led lit if overstepping of the 1st totalizer
 -99 999 > counting > 999 999
 (Hi.tot ≠ 0)

4.5.6 LOGIC inputs (optional)

- Board of 2 LOGIC inputs : Input signal 24 Vdc

Possible functions :

HoLd Holding of the instant value display in case of activation of the LOGIC function. The display and the analog output if it is dedicated to the instant value remain fixed in case of variation of the input signal. The relays and the totalizer carry on reacting to the input signal.

CLr.M Min. and max. zero reset. The activation of the LOGIC function resets the min. and max. to zero

tArE Activation of function tare. The meter switches to mode tare, the tare being the display value present at the time of this activation.

diSP Switching to the cumulated value display if LOGIC activated, if not instant value display.

totAL Function on the totalizer

Fct1 meter zero reset on ascending front, and counting.

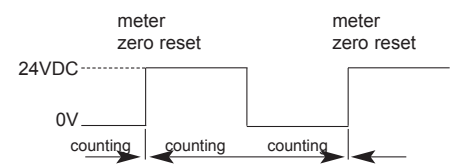

Fct2 zero reset on ascending front, and counting on low level only

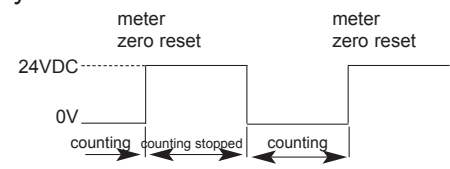

Fct3 zero reset on ascending front, and counting on high level only

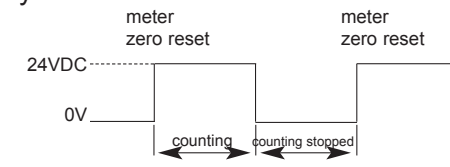

Fct4 Counting on high level only (no reset)

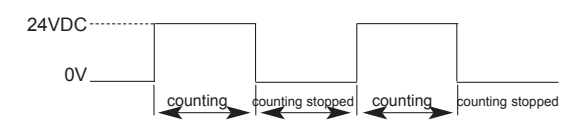

Fct5 Counting on low level only (no reset)

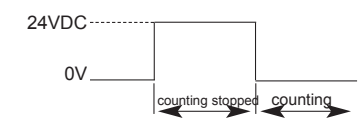

4.6 Output features and programming limits

4.6.1 Analog output Out.MA

Current output 0/4-20mA active

- Accuracy 0.1 % in relation to the display (at +25°C)
- Residual ripple $\leq 0.2\%$
- Admissible load $0\Omega \leq L_r \leq 500\Omega$
- Programmable scale ratio with enlarging effect
- Response time : 40 ms in relation to the display

PArA.0	Parameter applied to the output
InStA	Output on the instant value
TotAL	Output on the cumulated value
d.out	Analog output down scale (eg. 04.00 (4mA))
F.out	Analog output full scale (eg. 20.00 (20mA))
dO.diS	Display value corresponding to output down scale
FO.diS	Display value corresponding to output full scale

In mode measurement, the analog output can not overstepp 10% of the greatest of the 2 values : d.out and F.out

4.6.2 Digital output :

- Data link RS485 (2 wire)
- Protocoles **MODBUS-JBUS** format of data : integer and double integer
- Exclusive transmission format :
 - 1 bit start
 - 8 bits without parity
 - 1 bit stop

SLAvE	Slave number between 1 and 255
bAud	Transmission speed between 1200 and 19200 bauds
dELAY	Time delay before any response

Complete description of option MODBUS : see annexe documentation : MODBUS/JBUS.

Including : table of modbus addresses, used functions, description of the configuration bytes and advanced functions.

4.6.3 Relay outputs :

2 relay outputs rEL.1 rEL.2

- Relays programmable independently in mode alarm, or as pulses output
- NO-NC contact 8 A - 250 V on resistive load

Act.X	Activation or de-activation of relay x
On	The state of relay x depends on the carried programming
OFF	Relay x remains still.
tYPEX	Choice of relay x operating mode
AlArM	Mode alarm
PulSE	Mode pulses
PArA.X	Parameter applied to alarm X
InStA	Alarm X on the instant value
totAL	Alarm X on the cumulated value

Mode alarm

Choice of the operating mode ModEx

• Mode setpoint

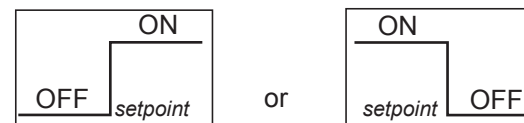

Legend :
 ON coil supplied
 OFF coil not supplied

• Mode window

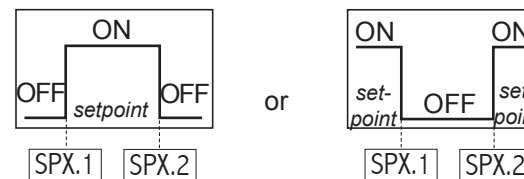

Choice of the state of the relay associated led

LEdx

The led indicates the alarm state.

On Led lit when relay active (coil supplied)

OFF Led still when relay active (coil supplied)

HYST.x Hysteresis setting in display points
The hysteresis is active on switching from lit led to still led; i.e. on switching out of alarm, as the led represents the alarm state.

• Mode setpoint

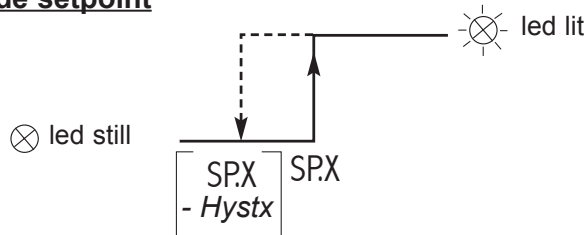

• Mode window

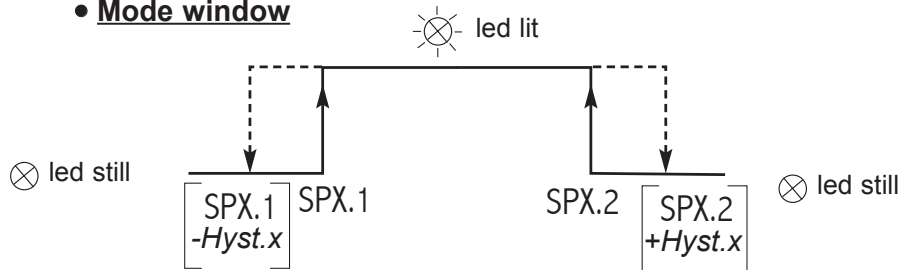

• Time delay on the alarm

tiME.x

The time delay on the relay is adjustable from 000.0 to 025.0s, in 0.1s increases

It is active both on switching and switching back.

• Alarm recording

MEM.x

Allows recording of the alarm after a setpoint has been passed. Once measure reverts below the alarm setpoint, the relay remains on and the led blinks to warn the user that a setpoint has been passed (to reset the recording of alarms to zero see menu **CLEAR** p21).

Note : Exit from mode programming with configuration saving will reset alarm recordings to zero.

• Display of alarm messages

MESSx

A programmed alarm message can be made to appear alternating with measure. The message will appear only during the alarm state, while the associated led is lit.

• Setting of setpoints

There are 2 ways to adjust setpoints.
- either in mode programming entering the correct access code
- or by pressing simultaneously on  and  if the access to quick entering has been authorized during the code programming (see p20).

Mode pulses

PrAt Weight of the pulse to be applied on the totalizer unit adjustable from -10 000 to +10 000.

eg. :

1 : one pulse at each increase of the totalizer unit

-1 : one pulse at each decrease of the totalizer unit

1000 : one pulse every 1000 increases of the totalizer unit

-1000 : one pulse every 1000 decreases of the totalizer unit

PtiME Pulse duration : 100ms, 200ms or 400ms.

Note : The programmed pulses duration applies both to the high and low level, in order to allow some time between two consecutive pulses. When the pulse frequency is too high in relation to the output capacity, they are stored in a buffer, and restituted as soon as the frequency drops again. A (SAVE, YES), a totalizer zero reset or a power supply cut will reset the buffers to zero.

4.6.4 Safeties

diAG

• Self-diagnosis

The meter permanently watches any drifts that may surge on its components. The self-diagnosis serves to warn the user in case of abnormal increase of these drifts, before they provoke false measures.

The self-diagnosis error information can be reported :

• On the display : An error message appears alternating with measure; an error code is registered and can be read in menu About

Coding :

- 1 : Programming error
- 2 : Gain error
- 4 : Offset error
- 8 : Input calibration error
- 16 : Output calibration error

If the instrument detects for instance an offset error (4) and a gain error (2) the **error code value will be 6** (4+2).

· On the relays :

- OFF No influence of a self-diagnosis error on the relay
- LO Relay de-activated (coil not supplied) in case of self-diagnosis error
- HI Relay active (coil supplied) in case of self-diagnosis error

Note : The led is either still or lit, according to its programming in menu rELAY.

If the relay is programmed in mode pulses, its state on sensor rupture and self-diagnosis error is blocked on position OFF.

· On the analog output

If a return value has been programmed
Value included between : 0 and 22 mA

• Sensor rupture ruPt

The sensor rupture can be detected on mV and current inputs if down and full scale > 3.5 mA.

The sensor rupture information can be reported :

· On the relay

- OFF No influence of the sensor rupture on the relay
- LO Relay de-activated (coil not supplied) in case of sensor rupture
- HI Relay active (coil supplied) in case of sensor rupture

Note : The led is either still or lit, according to its programming in menu rELAY.

If the relay is programmed in mode pulses, its state on sensor rupture and self-diagnosis error is blocked on position OFF.

· On the analog output

If a return value has been entered
Value between : 0 and 22 mA

- On the display : Message OPEn

Note : The sensor rupture detection has priority over the self-diagnosis.

• Sensor rupture disconnection (If mV input)

The sensor rupture can be disconnected, in order not to disturb some calibrators which may be sensitive to the rupture detection current.

In menu SECU :

- CAPt Activation of the sensor rupture, or not
- On Sensor rupture active
- OFF Sensor rupture disconnected

4.7 Configuration reading

rEAd

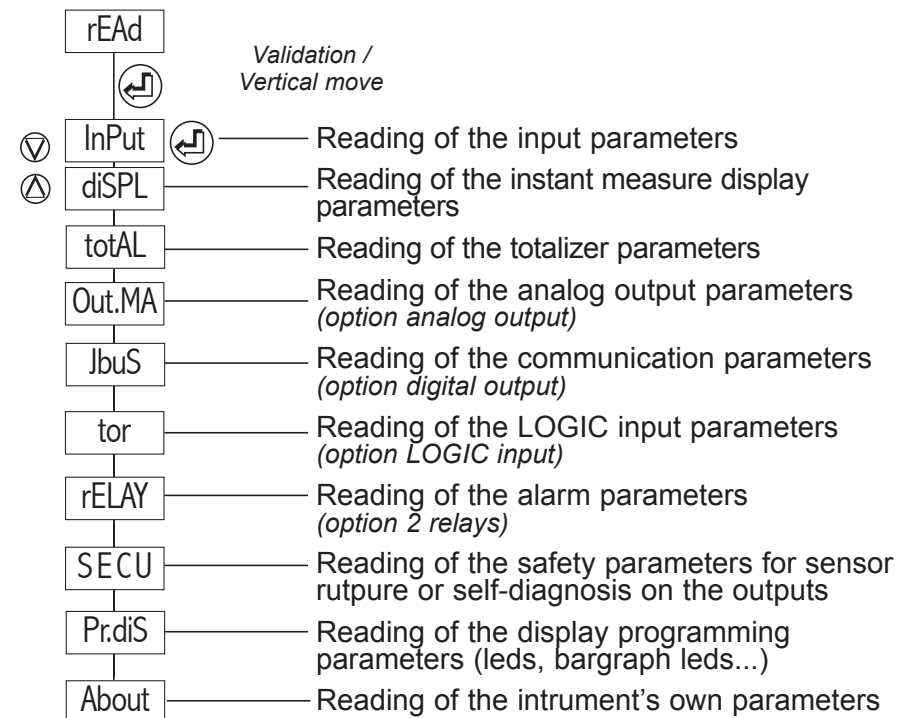

In each reading sub-menu, use keys ▽ and △ to move, and key ↶ to visualise parameters

If no key is pressed during 20 s., the instrument will automatically revert to measure display.

Sub-menu

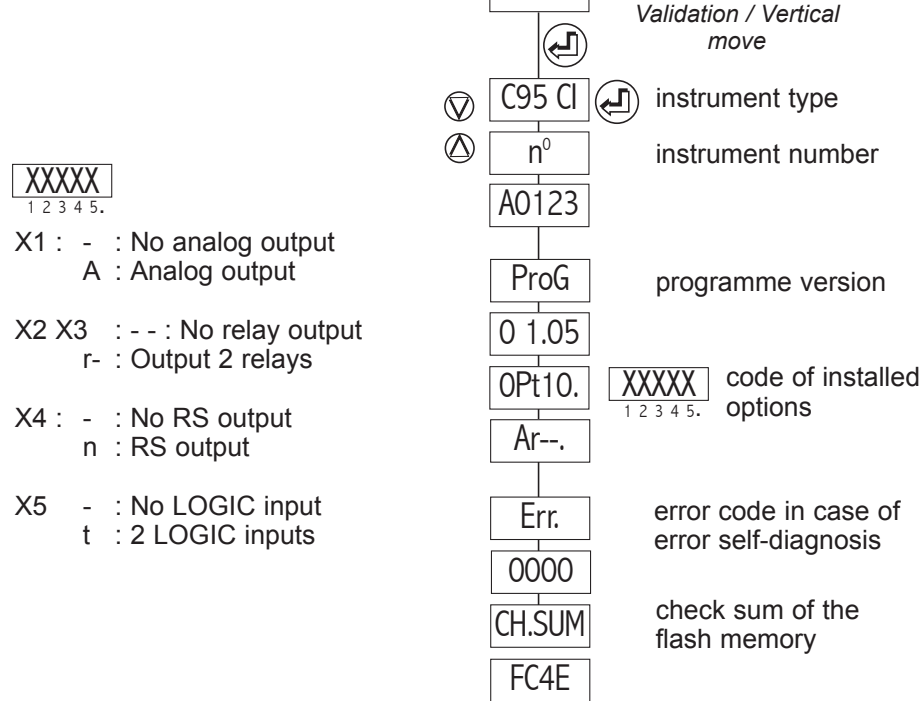

4.8 Access code

An access code adjustable from 00000 to 59999 serves to protect the meter from unauthorized programming, and to lock access to some functions.

0 0 0 0 0	Factory code
x x x x x	
0 to 5	Access to display shifting
6 to 9	No access
0 to 5	Access to display and output simulations
6 to 9	No access
0 to 5	Access to function "tare"
6 to 9	No access
0 to 5	Access to quick entering of alarm setpoints
6 to 9	No access
0 to 2	Access to the totalizer zero reset menu
3 to 5	No access

4.9 Programming of a new access code

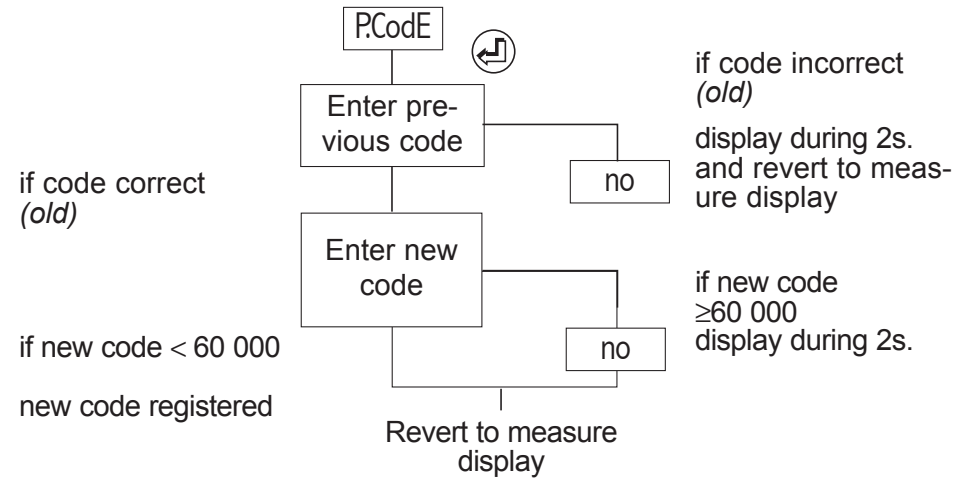

Reminder : If no key is pressed during 1 min, the instrument will automatically revert to measure display.

4.10 Functions accessible in the main menu

4.10.1 Display simulation

(accessible according to programmed access code and if option relays or analog output)

The display can be simulated with the meter in order to validate the configuration of the analog output, alarm and pulse outputs in the installation.

The simulated display corresponds to the one (instant or cumulated value) which was on display at the time of the access to this menu (the blinking led A or H indicates the type of this value).

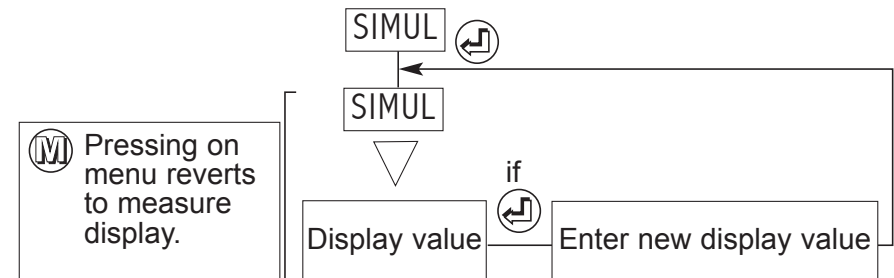

Note : The instrument does not measure during the simulation. The analog outputs, the alarm, the pulse outputs and the bargraph will react according to the value entered for simulation purpose. The totalizer stops during the simulation. It is saved, and will then be restored. If alarm messages have been programmed, they may appear during the simulation.

4.10.2 Analog output simulation (mode generator)

(accessible according to programmed access code and if option analog output)

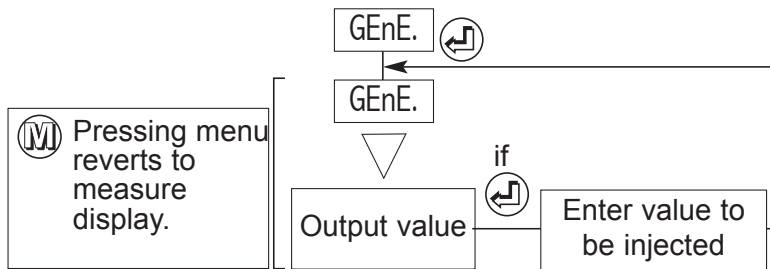

Note : The instrument carries on measuring during the simulation. Only the analog output no longer reacts to measure.

4.10.3 Menu CLEAR : Erasing of recorded alarms

If the function recording of alarms has been programmed, the relay state will be recorded after a setpoint has been passed.

If the setpoint is passed back the other way, the relay state does not change and the corresponding led starts to blink. To come back to the normal state (led not blinking and relay in the correct state) use menu CLEAR.

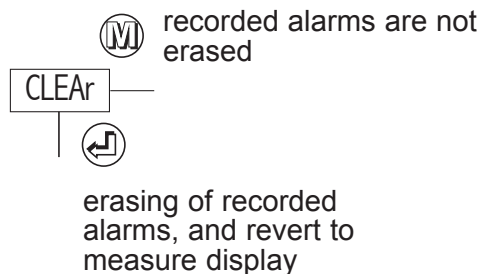

Reminder : If no key is pressed during 20 s., the instrument will revert to measure display.

Note : Exit from mode programming with configuration saving will reset alarm recordings to zero.

4.10.4 Menu CLrtA : Deleting of the programmed tare

(accessible according to programmed access code)

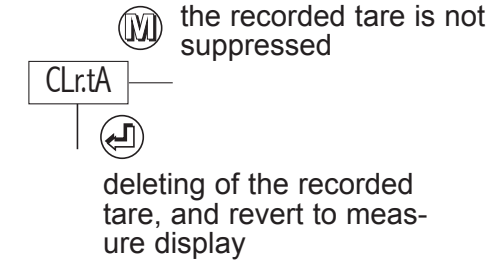

Reminder : If no key is pressed during 20 s. , the instrument will automatically revert to measure display.

Note : Exit from mode programming with configuration saving will reset the tare to zero.

5. FUNCTIONS ACCESSIBLE DIRECTLY FROM DISPLAY

5.1 Functions which require pressing only 1 key :

5.1.1 On instant value display

a / min. value display b/ Max. value display

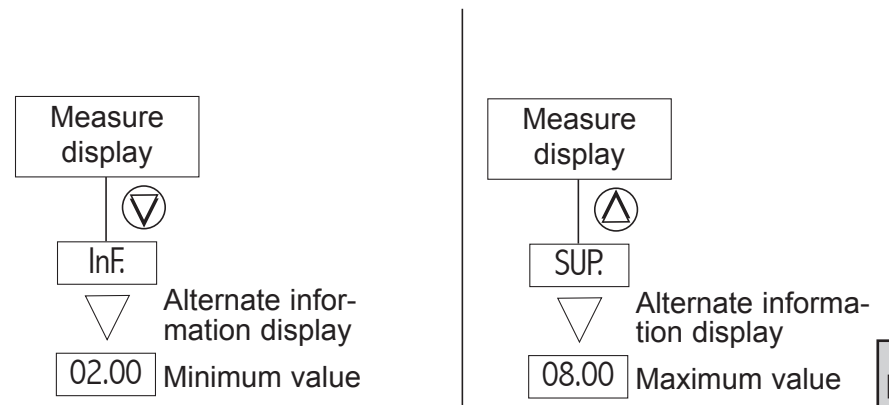

c / Deleting of maximum and minimum values

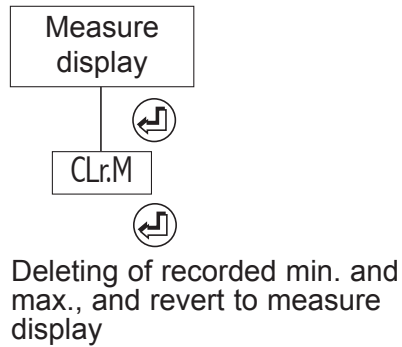

revert to measure display.

Reminder : If no key is pressed during 20 s., the instrument will revert to measure display.

Note : Exit from mode programming with configuration saving will reset min. and max. values to zero

5.1.1 On the totalizer display

a) *Totalizer upper part display*

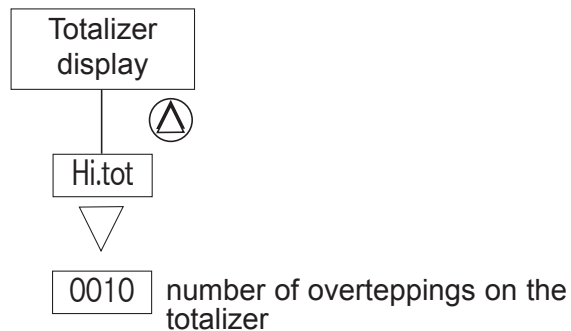

The cumulated value is :

Hi.tot x 1 000 000 + totalizer value if totalizer ≥ 0
and Hi.tot x -100 000 + totalizer value if totalizer < 0

b) *Access to the totalizer zero reset menu*

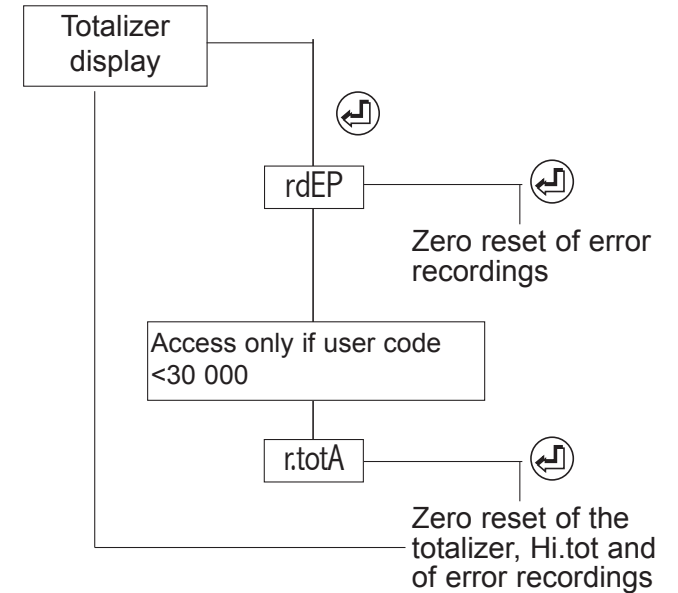

5.2 Functions which require pressing several keys :

5.2.1 Display shifting (only on the instant value display)

(accessible according to programmed access code)

Display down scale shifting (AdJ.Lo)

Display full scale shifting (AdJ.Hi)

After injecting an input signal corresponding to the down (or full) display scale, press simultaneously on keys and (or and). The message AdJ.Lo (AdJ.Hi) will appear alternating with the value, to indicate you are in menu adjustment.

The display down and full scale can be increased or decreased by pressing or .

Keep pressing during 3s. on key or to access a fast increasing or decreasing of the display value.

Press to validate the shifting. Once all shiftings are validated, the input thus shifted will keep its shifting even after a setting off tension.

Press (or do not press any key during 20 s) to revert to the measure display without modifications.

5.2.2 Tare setting (only on instant value display)
(accessible according to programmed access code)

Press and to enforce the signal present on the input as display down scale d.dISP

Note : The tare is not recorded in case of power supply cut.
To suppress the tare, go into menu CLr.tA in the main menu p6.
Exit from mode programming with configuration saving will automatically reset the tare to zero.

5.2.3 Changing of the displayed value

Press and to switch from the instant value to the totalizer, and vice-versa.

Led marking A blinking : instant value.

Led marking H blinking : totalizer

5.2.4 Direct measure visualising

Press and to visualise the signal directly without any processing : scale factor, square root, linearisation
– in mV, V or mA.

5.2.5 Visualisation and setting of alarm setpoints

Option 2 relays

Setting of setpoints : There are 2 ways to adjust setpoints.
- either in mode programming entering the correct safety access code
- or by simultaneous pressing on and

The meter will then show the message SP.x or SPx.x alternating with the value of the corresponding setpoint.

The various setpoint values can be accessed by or .

These setpoints can then be changed (according to the programmed access code, see p20) pressing or

Once the setpoint is adjusted, press to revert to the setpoints reading menu.

Once all setpoints are adjusted, just press and the meter will revert to mode measure, taking the new values into account.
If no key is pressed during 60 s., the meter will revert to measure display without taking the modifications of setpoint values into account.

6. ERROR or indication MESSAGES

Err.1 Value set out of range

On instant value display

2000 Value in overstepping

OPEn Sensor rupture

---- Input upper or lower electrical overstepping

O.L. Displayable value overstepping.

Er.xxx Self-diagnosis error

On totalizer display

01000 Counting overstepping
> 999 999 999
or < -99 999 999

totalizer



OPEN or -----

Electrical overstepping or sensor rupture recorded.

7. GENERAL WARRANTY TERMS

WARRANTY applying and duration

This appliance is guaranteed for a duration of 1 year against any design or manufacturing defects, under normal operating conditions.

Processing conditions * : Processing not under warranty will be submitted to the acceptance of a repair estimate. The customer will return the products at his charge, and they will be restored to him after processing. Without a written agreement on the repair estimate within 30 days, products will not be held.

* Complete warranty terms and details available on request.

8. LEXIQUE

Messages shown by the meter in mode programming and/or reading

General access

rEAd	Access to the reading of the parameters
ProG	Access to the programming of input and output parameters
CodE	Code for access to the programming of input and output parameters
P.CodE	Programming of a new access code
SiMUL	Access to display simulation
GEnE	Access to a simulation of the analog output
CLEAr	Deleting of recorded alarms
CLr.tA	Tare suppressing

Inputs

InPut	Access to the input programming sub-menu
tYPE	Input type
U	Voltage input
MA	Current input
CALib	Choice of the voltage caliber

0-10	Input 0 to 10 V (or -10/10V)
300	Input 0 to 300 V (or -300/300V)
0-0.1	Input 0 to 100 mV (or -100/100mV)
0-1	Input 0 to 1 V (or -1/+1V)

d.in	Input down scale
Fin	Input full scale
Funct	Choice of the processing function
LinEA.	Linear
root	Square root extraction
Li.SPE	Special linearisation
nb	Number of linearisation points
Axx	Abscisse of a special linearisation point

Instant value

diSPL.	Access to the display programming sub-menu
Point	Choice of the decimal point location
---.--	Decimal point location
d.diSP	Display down scale
F.diSP	Display down scale
bxx	Ordinate of a special linearisation point
Cut.oF	Cut-off programmable or not
IntEG.	Integration indice

Totalizer

dPtot	Choice of the decimal point location
----.-	Decimal point
Auto.P	Choice of the decimal point operating mode
no	fixed decimal point
yes	automatic decimal point

t.baSE Choice of the time basis

1 second

60 minute

3600 hour

CoeFF Conversion coefficient

MdeF Recording of errors, or not

LOGIC inputs

tor Access to the LOGIC inputs programming sub-menu

tor 1 Programming of LOGIC input 1

tor 2 Programming of LOGIC input 2

CLr.M Function erasing of min. and max.

HoLd Function display holding

tArE Function Tare

dSP.to Totalizer display / instant value display

totAL Function on the totalizer

FctX Function type X

Display parameters

Pr.diS Display features programming sub-menu

br.diG Adjusting of the digits brightness (4 levels)

1 1 1 1 Lowest brightness 4444 Strongest brightness

br.bAr Adjusting of the bargraph brightness

1 1 1 1 Lowest brightness 4444 Strongest brightness

L.dIG Last digit (low weight)

On Last digit in service OFF Last digit enforced to 0

nuLL Deleting of insignificant zeros

YES Yes no No

PArA.b Parameter applied to the bargraph

InStA Bargraph on the instant value

totAL Bargraph on the cumulated value

d.bArG Display corresponding to an extinguished bargraph (0%)

FbArG Display corresponding to a fully lit bargraph (100%)

Indic Bargraph in mode indication

LEdb Led marking b

no No dedication (led still)

tor1 Led lit when LOGIC input 1 is active

LEd C Led marking c

no No dedication (led still)

tor2 Led lit when LOGIC input 2 is active

LEdd Led marking d

no No dedication (led still)

RS Led lit during RS response from the instrument

LEdE Led marking e

no No dedication (led still)

tArE Led lit when a tare has been entered

LEdF Led marking f

no No dedication (led still)

M.dEF Led lit in case an error has been recorded

LEdG Led marking g

no No dedication (led still)

dEP.to Led lit in case of totalizer overstepping
-99 999 < counting > 999 999

Analog

Out.MA Access to the current output programming sub-menu

PArA.O Parameter applied to the output

- Output on the instant value
- Output on the cumulated value
- Analog output down scale
- Analog output full scale
- Access to programming of the display for output down scale
- Access to programming of the display for output full scale

Digital output

- Access to the RS output programming sub-menu
- Slave number
- Transmission speed (baud rate)
 - Possible speeds
 - Possible speeds
- Time delay before any response
 - Delay 75ms Delay 20ms

Relay outputs : x : 1 à 2

- Access to the relay outputs programming sub-menu
 - Access to the programming of relay x
- Activation of relay output 1
 - Activation De-activation
- Relay operating mode
 - Mode alarm
 - Mode pulses
- Parameter applied to the alarm
 - Alarm on the instant value
 - Alarm on the cumulated value
- Relay x operating mode
 - Mode setpoints
 - Mode window

- Setpoint value in mode setpoint
- 1st setpoint value in mode window
- 2nd setpoint value in mode window
- Hysteresis value in display points
- Time delay on relay X

- Programming of the relay associated led
 - Led lit when relay active (coil supplied)
 - Led still when relay active (coil supplied)
- Recording of alarm X
 - Recording No recording
- Alarm message
 - Message No message
- Pulse weight
- Pulse duration
 - 100 ms
 - 200 ms
 - 400 ms

Safeties

- Access to the safeties programming sub-menu
 - Programming of the sensor rupture safety
 - Sensor rupture activation (or not)
 - De-activated Active
 - State of relay X in case of sensor rupture
 - No sensor rupture associated with the relay
 - Relay de-activated in case of sensor rupture (coil not supplied)
 - Relay active in case of sensor rupture (coil supplied)

Return value (or not) on the output
in case of sensor rupture

Return value required No return value

Return value

Programming of the self-diagnosis safety

State of relay X in case of self-diagnosis error

No self-diagnosis associated with the relay

Relay de-activated in case of self-diagnosis error
(coil not supplied)

Relay active in case of self-diagnosis error
(coil supplied)

Return value (or not) on the output
in case of self-diagnosis error

Return value required No return value

Return value

Configuration saving

Configuration saving

Recording No recording

Reading of the instrument internal features

Access to the internal features reading sub-menu

Instrument type : C95 CI

Identification number

Programme version

Programme version number

Option code

Option code value

Self-diagnosis error

Type of error

Check sum display

Check sum value

Further functions

Minimum value display

Maximum value display

Deleting of min. and Max.

Zero reset of the error recordings

Totalizer zero reset

Value of the oversteppings counter

Error messages

Value set out of range

Sensor rupture

[↗] Blinking measure : measure in overstepping

Displayable value overstepping

Upper or lower electrical overstepping on the input

Self-diagnosis error

9. ANNEXE : MODBUS

9.1 Table of modbus addresses

Address		Format	nb of words
196	State of the totalizer	integer	1
197	Value of the oversteppings counter	integer	1
198	Value of the totalizer	double integer	2
200	Value of the analog output in μ A	double integer	2
202	Minimum value of the displayed value	double integer	2
204	Maximum value of the displayed value	double integer	2
206	Instant measure displayed	double integer	2
208	Direct measure	double integer	2
290	State of relay 1	integer	1
291	State of relay 2	integer	1

• Direct measure :

Value without scale factor for inputs 100 mV, 1V, 10V, 300V, 20 mA :

- in mV for the 10V input
- in 10th of mV for the 1V input
- in μ A for the mA input
- in 100th of mV for the mV input
- in 100th of V for the 300V input

• State of the relays :

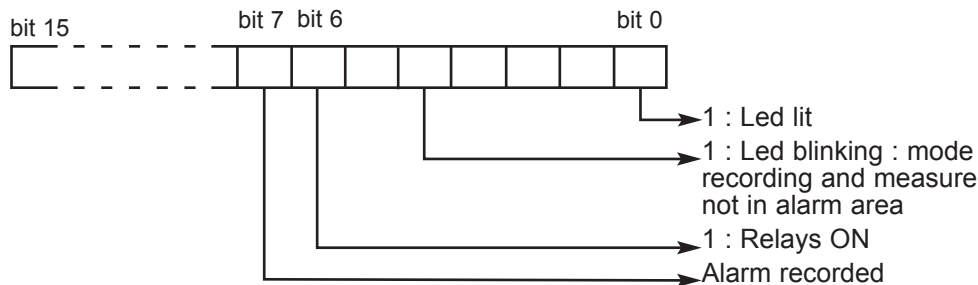

• Instant measure :

The instant measure value is shown on the display without the decimal point. To read the decimal point value, read the word at address 120.

Address 120 :

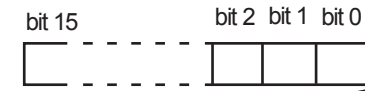

- *Decimal point location
- 1 : Display with 4 decimals
 - 2 : Display with 3 decimals
 - 3 : Display with 2 decimals
 - 4 : Display with 1 decimal
 - 5 : Display with 0 decimals

• Value of the totalizer :

The totalizer value is :

if value negative :

value of the oversteppings counter x -100 000 + totalizer value

if value positive :

value of the oversteppings counter x 1 000 000 + totalizer value

To know the decimal point, read the word at address 138.

Address 138 :

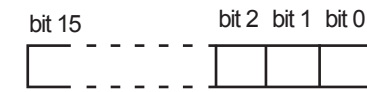

Location of the totalizer decimal point

- 1 : Display with 4 decimals
- 2 : Display with 3 decimals
- 3 : Display with 2 decimals
- 4 : Display with 1 decimal
- 5 : Display with 0 decimals

• State of the totalizer :

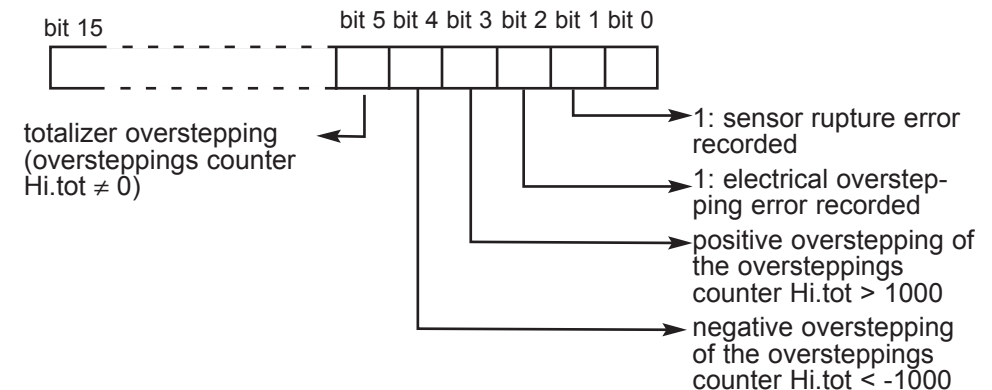

9.2 Description of born Modbus functions :

Reading of N words : Function n°3

Request pattern :

Slave number	Function 3 or 4	1st word address MSB	address LSB	Number of words MSB	of words LSB	CRC 16
1 byte	1 byte	← 2 bytes →		← 2 bytes →		2 bytes

Response pattern :

Slave number	Function 3 or 4	Number of bytes read	1st word value MSB	LSB	2nd word value MSB	LSB	CRC 16
1 byte	1 byte	1 byte	← 2 bytes →		← 2 bytes →		2 bytes

Writing of N words : Function N°16 :

Request pattern :

Slave number	Function 16	1st word address	Nbr of words to be enfor.	Nbr of bytes to be enfor.	Value of the words to be enforced	CRC 16
1 byte	1 byte	2 bytes	2 bytes	1 byte	← n bytes →	2 bytes

Response pattern :

Slave number	Function 16	1st word address	Number of words to be enf.	CRC 16
1 byte	1 byte	1 byte	2 bytes	2 bytes

Writing of 1 word : Function N°6 :

Request pattern :

Slave number	Function 6	Word address	Value of word to be enfor.	CRC 16
1 byte	1 byte	2 bytes	2 bytes	2 bytes

Response pattern :

Slave number	Function 6	Word address	Value of word to be enfor.	CRC 16
1 byte	1 byte	2 bytes	2 bytes	2 bytes

Values of the error codes :

- 1 : Function code unknown
- 2 : Address incorrect
- 3 : Data incorrect
- 9 : Writing impossible

Exception pattern :

Slave number	Function requested with MSB=1	Error code	CRC 16
1 byte	1 byte	1 byte	2 bytes

9.3 Reading in double integer format :

Example : Reading of the displayed measure

Request :

254	03	0	206	0	2	CRC 16
Slave number	Reading of n words	Address	Number of words			

• Response with a positive measure :

254	3	4	19	136	0	0	CRC 16
			byte 1	byte 2	byte 3	byte 4	2 bytes

Measure value :

byte 3	byte 4	byte 1	byte 2
00000000	00000000	00010011	10001000
0	0	19	136

↑ Sign : 0 positive
1 negative

$$\begin{aligned} \text{Measure} &= \text{byte 3} \times 256^3 + \text{byte 4} \times 256^2 + \text{byte 1} \times 256 + \text{byte 2} \\ &= 0 \times 256^3 + 0 \times 256^2 + 19 \times 256 + 136 \\ &= 5000 \end{aligned}$$

Reading of address 120 => decimal point = 2 => displayed meas. 50.00

• Response with a negative measure :

254	3	4	236	120	255	255	CRC 16
			byte 1	byte 2	byte 3	byte 4	2 bytes

byte 3	byte 4	byte 1	byte 2
11111111	11111111	11101100	01111000

↓ Sign : 1 negative : inverting of bits and adding of 1.

	byte 3	byte 4	byte 1	byte 2
Inversion	00000000	00000000	00010011	10000111
	byte 3	byte 4	byte 1	byte 2
Plus 1	00000000	00000000	00010011	10001000
	0	0	19	136

$$\begin{aligned}
 \text{Measure} &= -(\text{byte 3} \times 256^3 + \text{byte 4} \times 256^2 + \text{byte 1} \times 256 + \text{byte 2}) \\
 &= -(0 \times 256^3 + 0 \times 256^2 + 19 \times 256 + 136) \\
 &= -5000
 \end{aligned}$$

Reading of address 120 => decimal point = 2 => displayed meas. -50.00

9.4 CRC 16 calculation algorithm :

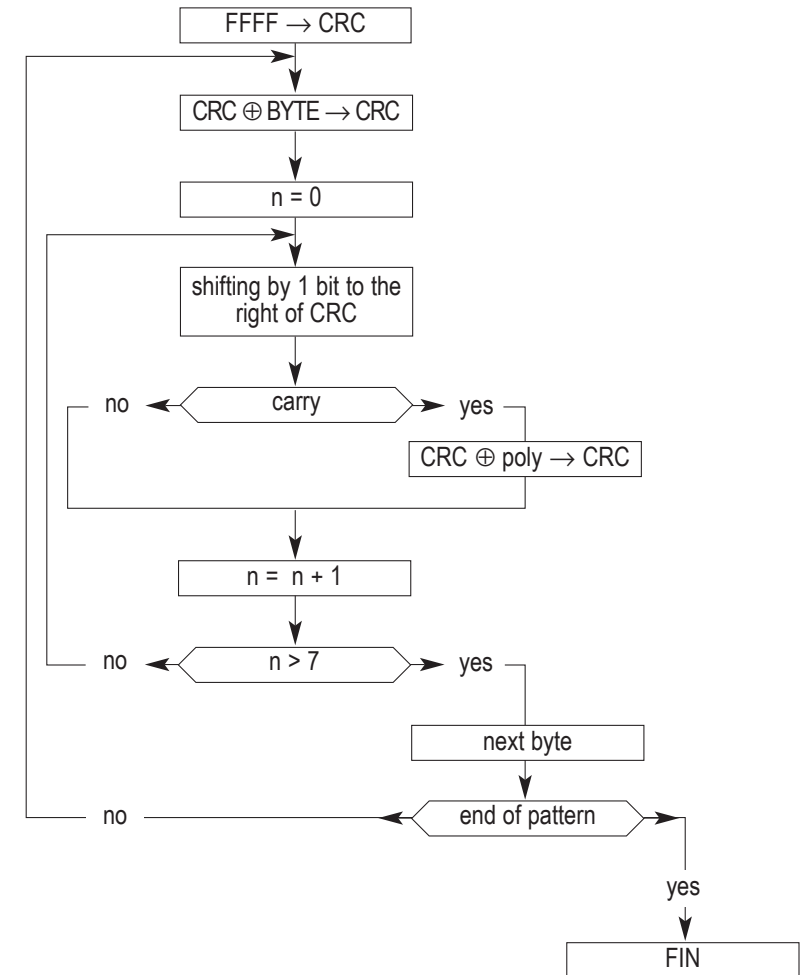

Note 1 : ⊕ = exclusive or.

Note 2 : POLY = A001 (hex).

Note 3 :
The CRC16 calculation applies to all bytes in the pattern (except CRC16).

Note 4 :
Caution ! In the CRC 16, the 1st sent byte is the LSB.

Example : Pattern 1-3-0-75-0-2 CRC16 = 180-29 (values are decimal).