

Contents

1.	Brief description	2
1.1	Measuring principle	2
1.2	Official approvals	2
2.	Installation	3
3.	Start-up	4
4.	Maintenance	4
5.	Options (ES..., P..., K...)	4
5.1	Limit switches TG 22	5
5.2	Transistor relays	6
5.3	Electrical signal output ... ES	7
5.4	Pneumatic signal output ... P	8
6.	Changing the wire cable	8
7.	Level gauge versions, components	9
8.	Float selection	10
9.	Technical data	11

1. Brief description

The BM 24 level gauge is used for measuring liquid levels in open-topped or pressurized vessels and tanks. It can be equipped with electrical limit switches and/or with an electrical or pneumatic data teletransmission system.

Scope of supply

- Indicator housing with follower magnet and complete set of parts for connection to the mounting flange (1 gasket, 4 stud bolts, 4 washers, 4 nuts)
- Float
- Guide tube with mounting and connection flanges

1.1 Measuring principle

A float with built-in magnet system is guided on a non-magnetic tube. It follows the liquid level in the vessel, thereby causing the magnet system to move the follower magnet inside the tube. Changes in level are transmitted via a flexible wire cable to a measuring drum. The weight of the follower magnet is balanced by a spring motor. System operation is thus non-interacting. The indicating device and teletransmission system are actuated by the measuring drum via a toothed gearing.

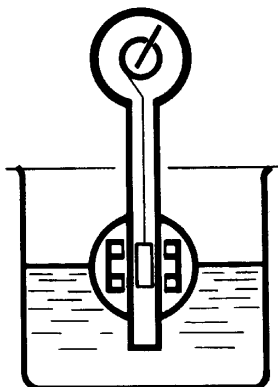

1.2 Official approvals

■ Physikalisch-Technische Bundesanstalt:

Certified under PTB No. III B/S 1017, PTB No. III B/S 1930 and PTB No. Ex-83/2015 as level gauge for flammable liquids of dangerous-materials classes AI, AII and B (Zone 0), except for carbon disulphide.

■ German Lloyd:

Certified under No. 61 110 HH as hazardous-duty level gauge for products of all dangerous-materials classes and categories.

■ Dienst vor het Stromweezen:

Certified for the Netherlands under No. 74A012.

■ BASEEFA:

Certified under BAS No. Ex 83 23 30 and BAS No. Ex 83 23 31 for use in hazardous areas. (For Europe excluding FRG, not Zone 0.)

Note:

Approved units are not standard versions! Variations in design and technical data are possible!

2. Installation

The float guide tube forms a gas-tight and pressure-resistant partition between the liquid chamber and the magnetic data transmission system.

The float is designed for a specified liquid and specified operating conditions. Its depth of immersion is determined by its weight and the density of the liquid, and is marked at the appropriate level by an inverted triangle.

General information:

(not for hazardous-duty units)

Flanges > DN 150 are supplied loose together with the gauge and must be welded at site.

Guide tubes > 6 m are at the customer's request supplied in divided lengths. Both tube ends are turned to fit and must be joined and welded at site.

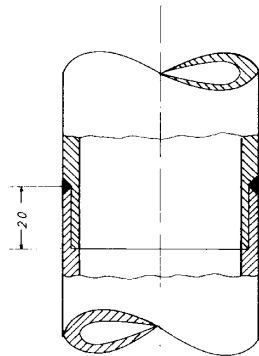

(The required electrodes of CrNi steel 1.4576 are included in the supply.) Ensure the guide tube is kept straight during welding work. To allow proper working of the float and follower magnet, make absolutely sure that the weld does neither burn-through nor change the outside diameter of the guide tube. Finally test weld for leak-tightness ($1.3 \times$ vessel pressure).

- Before installation, remove stoppers and protective covers from the indicator housing flange and the guide tube connecting flange.
- Avoid installation work during rain and snowfall.
- Use compressed air or a special pump to remove all traces of moisture (condensation).
- Place gasket on the vessel mounting flange.
- Remove limit stop from the guide tube and insert guide tube through the mounting flange.
- Slip the float (right side up) from below onto the guide tube.

Right side up: stick-on label shows "top" and "bottom", red triangle inverted.

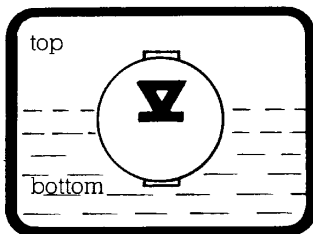

- Replace limit stop and secure with split pin.
- Lower the guide tube and screw firmly to the vessel mounting flange.

With versions where the pipe diameter of the vessel flange is ≥ 300 mm, the float can first be fitted to the guide tube and then both inserted through the mounting flange into the vessel.

Tank bottom attachment for guide tube

If the level gauge is to be installed in ships, or where moving liquid levels in general are concerned, a tank bottom attachment is recommended to prevent buckling of tubes in excess of 3 m length. The bottom attachment of guide tubes longer than 3 m is officially required for level gauges used in Zone "0" locations.

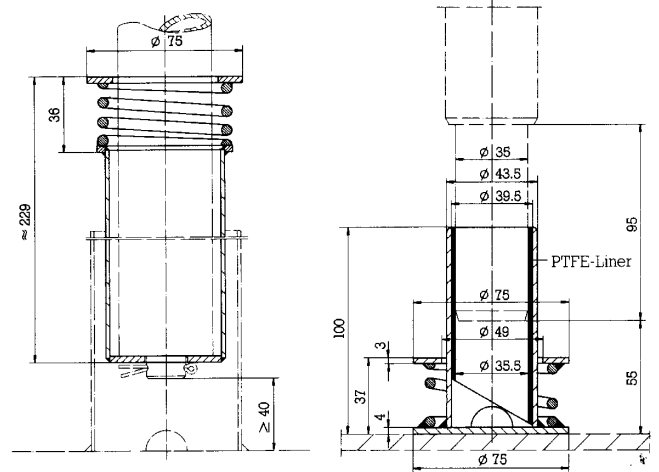

Weld the tube attachment to the tank bottom in alignment with the connecting flange.

Allow for vertical and horizontal play of the guide tube.

Guide tube versions Al, Htg., PP

(not for hazardous-duty units)

These tubes feature a limit stop in the form of a welded bush with inserted split ring and a sleeve that is slipped over from above. The limit stop is secured by grub screws.

When supplied, the limit stop is in assembled condition on the guide tube, and must be removed before the float can be fitted.

- Loosen grub screws (3) until the sleeve (1) can be moved upwards.
- Remove both ring halves (2) and slide sleeve (1) off guide tube.
- Slip float onto guide tube and then replace sleeve (1).
- Insert both ring halves.
- Slide sleeve (1) over the ring halves (2) up to the stop and fix the grub screws (3).

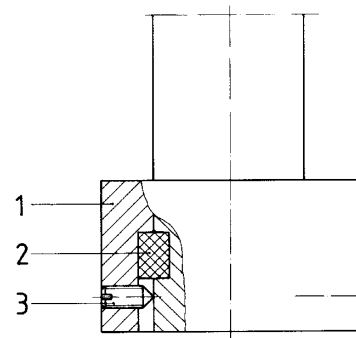

- 1 Sleeve
- 2 Ring halves
- 3 Grub screw

Guide tube version PTFE

(not for hazardous-duty units)

The limit stop consists of a screw cap.

This cap is screwed to the guide tube after the float has been fitted.

A special Viton gasket is used for sealing the guide tube.

3. Start-up

- Place indicator housing on its side on a firm support on a level with the connecting flange.
 - Place gasket on the connecting flange.
 - Thread the wire cable through the hole in the follower magnet and knot the end.
 - Attach a rope clamp to act as lift limiter approx. 200 mm above the follower magnet.
 - Pay off wire cable uniformly from the measuring drum against the force of the spring motor, and lower the follower magnet down into the guide tube.
- Polarity of follower magnet: north at top, south at bottom; vice versa for float ring magnet. Accordingly, like poles (repelling one another) meet first.
- Lift follower magnet approx. 200 mm and let it fall freely through the repelling magnet system. It will then be held by the magnet system in the float.
- To check: greater resistance should be noticed when tugging on the wire cable, or when turning the measuring drum if the level gauge is of the built-in type. The magnetic bonding force is approx. 25 N.
 - Do not bend or damage the wire cable in any way.
 - Position the indicator housing on the guide tube flange and screw it down.

The wire cable is kept taut by the spring motor.

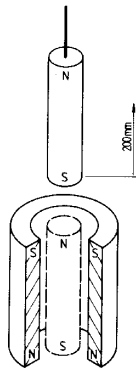

Presetting dimension „V“

The particular design of the level gauge requires use of a presetting dimension "V" to enable a level of "0 m" to be indicated when the tank is empty. This dimension "V" comprises the following factors: depth of immersion of the float (marked by an inverted red triangle) and the distance between top edge of limit stop on the guide tube and the bottom of the tank.

$$V = a + h$$

a = distance between tank bottom and top edge of limit stop on guide tube

h = float depth of immersion

Dimension "a" will be specified in the tank drawing or must be measured in the tank.

Immersion depth "h" is marked on the float (refer to Section 2, Installation) or can be read off from the relevant float chart (Section 6) "depth of immersion vs. product density".

Adjustment of the measuring system

- Make sure that the float is resting against the limit stop of the guide tube in the empty tank.
- Determine presetting dimension "V".
- Remove large "centimetre" hand (slotted set screw, slot size 0.6).
- Use slip coupling to set the small "metre" hand to presetting dimension "V" on the metre scale.
- Replace "centimetre" hand, set to presetting dimension, and tighten the fixing screw.
- Check movement of the hands on the scale by lifting the float.
- Remove stick-on label from float and guide tube (contamination of liquid product).
- Screw down both housing covers. The inserted O-ring forms the seal. Adjustment procedure completed.

Level gauges for low-temperature installations

In installations operated below 0 °C, the air in the guide tube and indicator housing must be replaced by nitrogen, otherwise condensed moisture from the air would cause the follower magnet to freeze fast in the guide tube.

- Insert a hose down to the bottom of the guide tube.
- Flush first the tube then the housing with nitrogen.
- To absorb residual moisture, place a bag of silica gel in the indicator housing before sealing and screwing down.

When flushing the level gauge with nitrogen, make sure that the applied internal pressure of max. 0.05 bar (0.005 MPa) is not exceeded.

4. Maintenance

After approx. 1 year's operation, lubricate the journals in the indicator system and the windings of the spring motor with resin- or acid-free oil.

If liquids are contaminated or contain solids with a settling tendency, clean the guide tube and float slide at regular intervals to ensure free movement of the float.

5. Options (ES..., P..., K...)

All level gauges can be fitted with one or several options.

Possible combinations: K.../ES...
K.../P...
ES.../P...

Actuation is transmitted via an auxiliary gearing from the measurement mechanism to the transducer or limit switches.

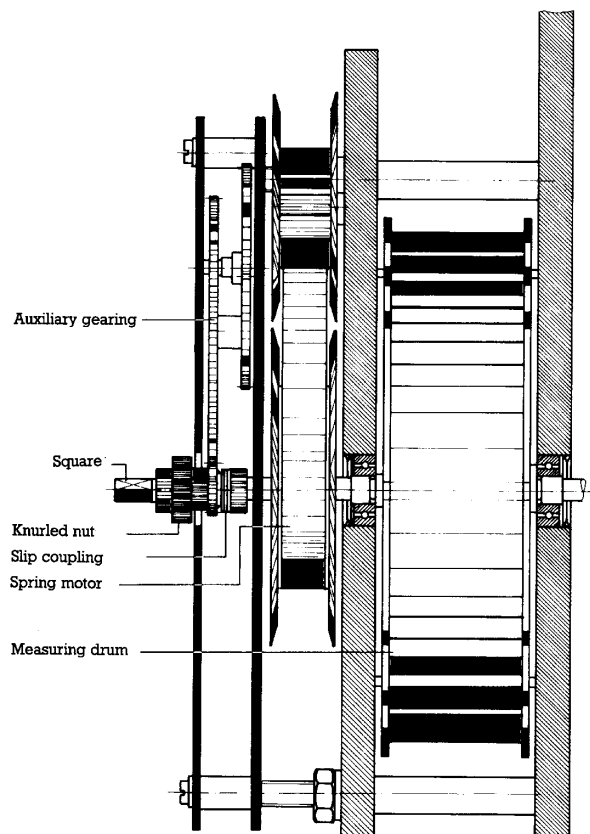

5.1 Limit switches TG 22

Up to 4 TG 22 electrical limit switches can be installed in the BM 24 level gauge to signal specific levels.

The TG 22 is a slot initiator of type SJ 3.5-N manufactured by Pepperl & Fuchs. They are matched for transistor amplifiers with intrinsically safe control circuit to NAMUR and DIN 19 234. Transistor amplifiers WE/Ex-1 for one and WE/Ex-2 for two control circuits are available from stock.

Adjustment

The threshold values at which an electrical signal is to be initiated are freely selectable.

- Signalling is effected by slotted discs which dip into a slot initiator.
- The slotted discs can be turned relative to each other when the measuring drum is in locked position.
- Annunciators (Hima, Pepperl & Fuchs, Siemens, etc.) are required for signal evaluation. WE/Ex switching relays made by Pepperl & Fuchs, control circuit in protection category (EEx ib) II C, with 500 VA, 4 A, 250 V relay output switching capacity, are supplied as standard equipment for these and for the ex-proof version.
- To set the operating point, first set the operating point on the indicating system (raise the float or reel in the cable). To do this, remove indicator housing from the guide tube.
- Lock measuring drum or secure wire cable.
- To set contact 1, turn the complete limit switch via the slip coupling until a signal is initiated at the preset measured value.

For contacts 2-4, turn the slotted discs until relevant signals are initiated at the other measured-value thresholds.

The operating point is located precisely in the middle of the slot initiators.

- This completes the adjustment procedure.
- Lower the follower magnet down through the guide tube until it links up with the float magnet.
- Replace indicator housing.

Action

TG 22 consists of a slot initiator and separately mounted transistor amplifier. Dipping of the slotted disc into the slot initiator causes damping of the electrical resonant circuit and triggering of the switching pulse.

The TG 22 is also suitable for use in conjunction with hazardous-duty systems, but the transistor amplifier must be installed outside the hazardous area; alternatively, use (Ex)3n G5 type of enclosure.

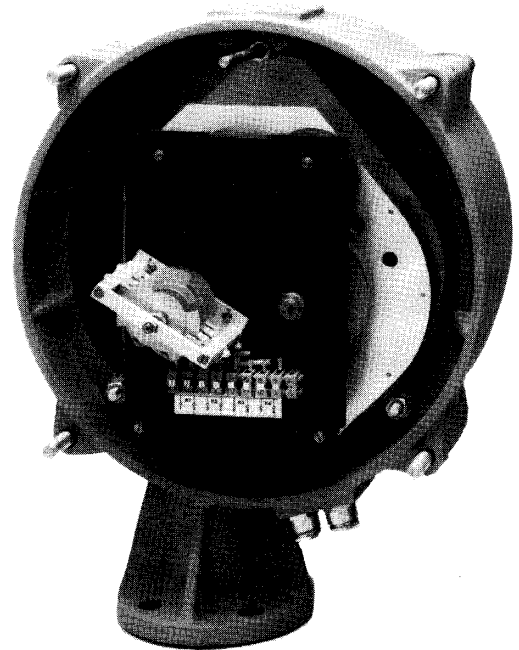

Connection diagram

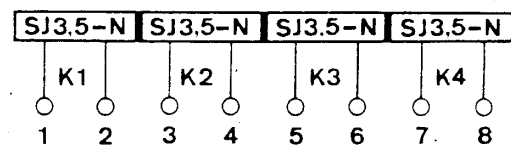

Limit switches

1. K 1 Terminals 1,2
2. K 2 Terminals 3,4
3. K 3 Terminals 5,6
4. K 4 Terminals 7,8

Technical data

Limit switch TG 22

Rated voltage	8 V DC
Power consumption	
Active area clear	≅ 3 mA
Active area obscured	≅ 1 mA
Self-inductance	160 μH
Self-capacitance	40 nF
Ambient temperature	-25 °C to +100 °C

Electrical characteristics in conformity with DIN 19234 and NAMUR

5.2 Transistor relays WE/Ex

WE/Ex-1 and WE/Ex-2 transistor relays consist of a power supply unit, transistor switching amplifier and relay output. WE/Ex-1 features one and WE/Ex-2 two intrinsically safe control circuits in conformity with DIN 19 234 and NAMUR.

The control circuits are approved by the Physikalisch-Technische Bundesanstalt in protection category "Intrinsic Safety" [EEx ia] II C or [EEx ib] II C under PTB No. Ex-79/2043 X.

Connection diagrams

- 1 Initiator
- 2 Power (line connection)
- 3 Relay output

WE/Ex-1

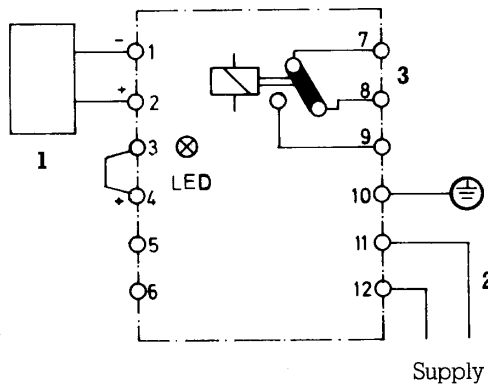

WE/Ex-2

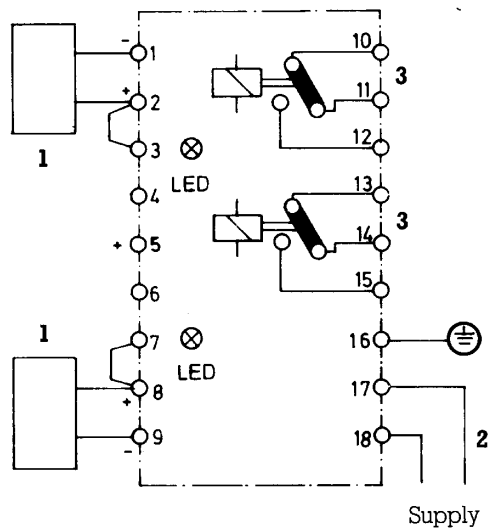

When supplied, the relays are equipped with wire links for open-circuit operation. If operation with closed-circuit current is required, simply transpose the wire links. If the wire links are removed altogether, the relay operates with closed-circuit current and additional open-circuit monitoring feature. The open-circuit state is then signalled by an LED.

Dimensions (mm)

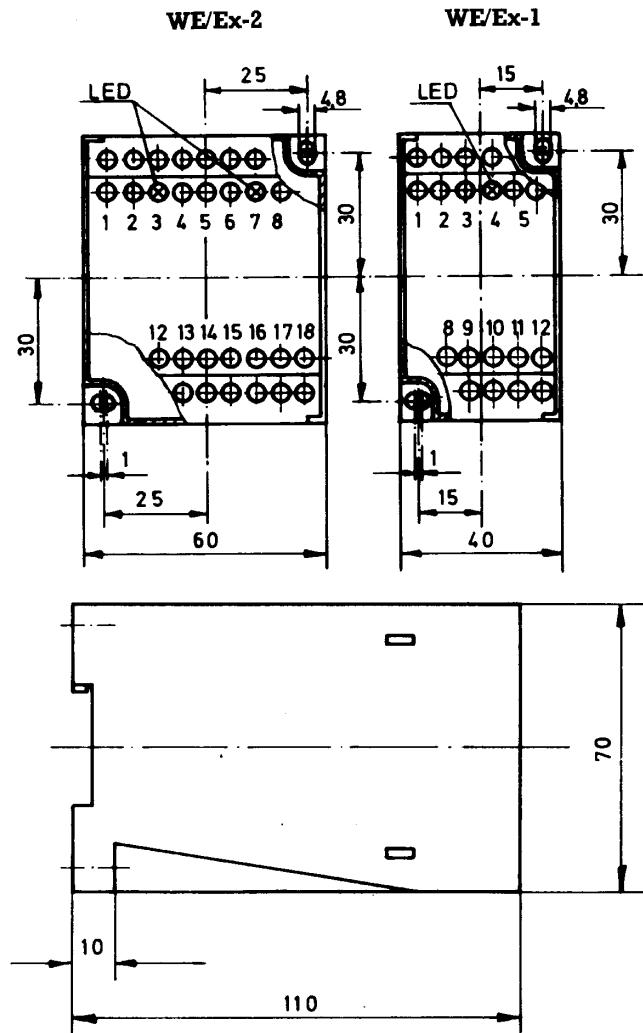

Technical data

Power supply

Standard	220 V AC
Special	24 V DC, 127 V AC, 110 V AC, 42 V AC, 24 V AC

Power consumption approx. 3.5 VA

Ambient temperature - 25 °C to + 60 °C

Protection category

to DIN 40 050 IP 30

Control circuit

	WE/Ex-1	WE/Ex-2
Open-circuit voltage	8 V DC (13.5 V)	8 V DC (13.5 V)
Short-circuit current	8 mA (31 mA)	8 mA (62 mA)
Permissible inductance	3 mH (31 mH)	1 mH (7.6 mH)
Permissible capacitance	230 nF (609 nF)	160 nF (539 nF)
Figures in brackets	max. values for ex-proof systems	

Output stage

Type of switch	1 changeover contact
WE/Ex-1	2 changeover contacts
WE/Ex-2	4 A/250 V/500 VA/cos φ = 0.7

Mode of operation	WE/Ex-1		WE/Ex-2	
	Link between terminals	Link between terminals	Link between terminals	Link between terminals
Open-circuit current	3-4	2-3	7-8	
Closed-circuit current	4-5	3-4	6-7	
Closed-circuit current with open-circuit monitoring	none	none	none	none

5.3 Electrical signal output ... ES

The KINAX 5W1 angle-of-rotation transducer (make: Camille Bauer) is built into the indicator housing to convert liquid level data into an impressed current of 0(4) to 20 mA.

The KINAX 5W1 is also suitable for use in hazardous areas if powered by an intrinsically safe circuit.

In terms of explosion protection, the KINAX 5W1 angle-of-rotation transducer functions like a passive dipole. Operation in hazardous areas is permitted provided the power supply is obtained from a voltage source with certified intrinsically safe circuit.

The supply power must be a DC voltage that can be drawn from an existing DC source or from power supply units (rectifier, transducer feeder unit).

All instruments powered by the measuring circuit (indicators, recorders, etc.) to be series-connected and must not exceed the maximum load of the angle-of-rotation transducer. For hazardous-duty units, all instruments must have an intrinsically safe input; otherwise, use combined power supply and isolating transducer units.

Connection diagrams

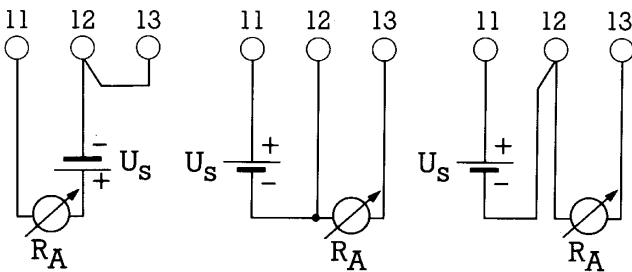

4 to 20 mA

2-wire circuit

0 to 20 mA

3-wire circuit

0 to 20 mA

4-wire circuit

U_s supply voltage

R_A external resistance

KINAX 5W1 connection terminals

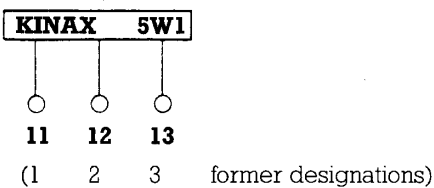

Adjustment of the electrical signal output

1. Instrument required: 0 to 20 mA milliammeter.
2. Set presetting dimension "V".
3. Connect angle-of-rotation transducer as shown in the circuit diagram together with a local indicating instrument, and switch on.
4. The angle-of-rotation transducer has been factory-set to 0–100% measuring range, as ordered. These values are not identical with the full-scale range (e.g. measuring range 0 to 3.8 m, but full-scale range 6.0 m).

	at 0 to 20 mA	at 4 to 20 mA
0% \cong 0 m	0 mA	4 mA
10% \cong 0,38 m	2 mA	5,6 mA
50% \cong 1,9 m	10 mA	12 mA
100% \cong 3,8 m	20 mA	20 mA

5. At the mounting location, the full-scale range must be adjusted to agree with the electrical full-scale range.
6. Remove indicator housing from the guide tube connecting flange.
7. Pull the wire cable with follower magnet out of the guide tube and slowly wind it up onto the measuring drum (thereby cancelling the magnetic bond between the two magnets).
8. At 100% measured-value indication, the output signal of the transducer must be exactly 20.0 mA. If not, turn the complete angle-of-rotation transducer via the slip coupling until a precise 20.0 mA reading is obtained.
9. The two potentiometers in the angle-of-rotation transducer have been factory-set and paint-locked, and may only be readjusted if the measuring range is to be changed.
10. Electrical adjustment of the full-scale range means that the zero is automatically correct, since full-scale range and zero were set during factory calibration.
11. Lower the wire cable with magnet down through the guide tube to re-establish the magnetic bond with the float magnet system.
12. Replace indicator housing. This completes the adjustment procedure.

Technical data

Angle-of-rotation transducer KINAX 5W1

Power supply	12 to 36 V DC max. 22 V for hazardous-area operation
Power consumption	approx. 25 mA
Self-inductance	2 mH
Self-capacitance	15 nF
Ambient temperature	– 25 °C to + 60 °C
3- or 4-wire connection	0 to 5 mA, max. 2400 ohms 0 to 10 mA, max. 1700 ohms 0 to 20 mA, max. 850 ohms
2-wire connection	4 to 20 mA, max. 600 ohms
Linearity	$< \pm 1\%$ at 1 max.
Temperature effect	$< 0.5\%/10\text{ }^\circ\text{C}$
Power supply effect	$< 0.2\%$
Dependence on external resistance	$< 0.2\%$ at ΔR_A max.
Repeatability	$\pm 0.2\%$
Max. external resistance 2-wire connection	$R_A = \frac{U_B [\text{V}] - 12 [\text{V}]}{I_A [\text{mA}]} [\text{k}\Omega]$
3- and 4-wire connection	$R_A = \frac{U_B [\text{V}] - 5,3 [\text{V}]}{I_A [\text{mA}]} - 0,335 [\text{k}\Omega]$
	U_B = power supply I_A = max. output current

5.4 Pneumatic signal output ...P

The WT 80 pneumatic transmitter with VR 80 amplifier is used to convert the measured liquid level into a pneumatic signal. Activation is via cam disc.

Start-up

- Use only clean, oil- and moisture-free air to operate the transmitter.
- Blow out air lines before connecting up.
- Initial air feed pressure should be 1.4 bar; there must not be any noticeable drop in pressure when the measuring system is fully modulated (100% values).
- Leak-tightness: pressure test, check screw connections with leak indicator spray.

Adjustment of the pneumatic signal output

1. Instrument required: Class 0.2 precision pressure gauge, connected to the signal output of the unit. Connect up feed air supply.
2. Set presetting dimension "V".
3. Remove indicator housing.
4. Pull wire cable out of the guide tube and allow it to wind up slowly on the measuring drum up to the fullscale value (thus cancelling the magnetic bond between float magnet system and follower magnet).

The signal output 0.02 MPa (0.2 bar) to 0.1 MPa (1 bar) corresponds proportionally to a measuring range of e.g. 0–3.8 m. In the event of deviations, set the transmitter (1) via the slip coupling (3) to the lower range limit "0 m" (0.2 bar). The measuring distance can be adjusted by paying out or reeling in the wire cable on the measuring drum. The full-scale range 3.8 m (1 bar) can be corrected via the knurled-head screw (5).

Subsequently recheck the zero point and, if necessary, correct via the knurled-head screw (4).

Readjust zero and full-scale range alternately until they coincide with the relevant output signals.

5. Lower wire cable with follower magnet down through guide tube to form a bond with the float magnet system.
6. Replace indicator housing.
This completes the adjustment procedure.

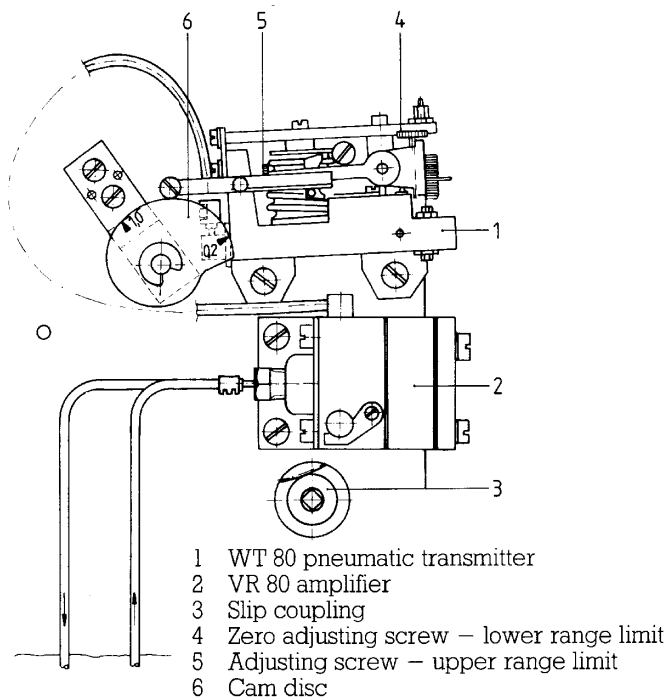

- 1 WT 80 pneumatic transmitter
- 2 VR 80 amplifier
- 3 Slip coupling
- 4 Zero adjusting screw – lower range limit
- 5 Adjusting screw – upper range limit
- 6 Cam disc

Technical data

Pneumatic transmitter WT 80

Supply air pressure	0.14 MPa ± 0.01 MPa (1.4 bar ± 0.1 bar)
Air consumption	480 l/h
Air capacity	1800 l/h
Output	0.02 to 0.1 MPa (0.2 to 1.0 bar [3 to 15 psi])
Linearity	± 0.5%
Hysteresis	0.25%
Sensitivity	0.1%
Ambient temperature	– 25 °C to + 70 °C
Temperature effect	0.03 %/°C
Inlet pressure dependence	0.2%/0.01 MPa (0.1 bar)
Load characteristic at 0.06 MPa (0.6 bar)	1.2% at 300 l/h 3% at 600 l/h
Connections	1/8" NPT

6. Changing the wire cable

1. Disconnect flanged connection between indicator housing and guide tube.
2. Pull wire cable and magnet out of the guide tube. (If follower magnet has become detached: fetch wire end and magnet out with a special catching device obtainable from our Service Dept.)
Reel in wire cable using the spring motor up to the end stop.
3. Remove both housing covers.
Disconnect any rear-mounted electrical/pneumatic lines.
Undo the three screws and remove gear unit from housing.
4. Pay off wire cable from the measuring drum against the force of the spring motor up to the end stop.
5. Turn the measuring drum until the knotted end of the wire is visible through the hole in the rear baseplate. Secure measuring drum against turning.
6. Pull out the knot using pincers or a hook and cut it off. Remove rest of wire from measuring drum.
7. Slide the leading end of the new wire cable through the cable guide and thread it from outside through the small hole in the measuring drum. Then pull it through the hole in the baseplate, tie a knot in the end and cut off excess wire. Pull the knot back to the end stop in the measuring drum. Release the measuring drum.
8. The force of the spring motor will automatically wind the wire cable onto the measuring drum. Guide the cable by hand to avoid looping.
9. Wind an adequate length of cable onto the measuring drum (one full turn = 0.5 m).
10. When a sufficient length of cable has been wound up, pull cable through the cable guide, attach a rope clamp and cut off cable 0.5 m behind the clamp. Secure gear unit with three screws in the indicator housing.
11. Thread the end of the cable outwards through the flange and attach the follower magnet.
12. For partially filled tanks, proceed as described in Section 3 Start-up. Measure current liquid level with a yardstick and transfer this reading to the indicator. For empty tanks, proceed as described under Presetting Dimension "V" and Adjustment of Measuring System. Check setting of options and readjust if necessary (see Sections 5.1–5.3).
13. Place indicator housing on guide tube and screw down.
14. Replace both indicator housing covers and screw down.

7. Level gauge versions, components

Designation	Guide tube (mm)	Flange
BM 24/N	stainless steel dia. 44.5 × 2.5 or 48.3 × 3.6	St 37
BM 24/NR	stainless steel dia. 44.5 × 2.5 or 48.3 × 3.6	St 37, stainless steel 1.4571 coated
BM 24/RR	stainless steel dia. 44.5 × 2.5 or 48.3 × 3.6	stainless steel 1.4571
BM 24/N-Htg Hard rubber sheathed	stainless steel dia. 44.5 × 2.5, hard rubber sheathed*	St 37, sealing strip of hard rubber
BM 24/N-PP Polypropylene sheathed	stainless steel dia. 44.5 × 2.5 with polypropylene sheath*	St 37, sealing strip of PP
BM 24/N-PTFE Polytetrafluoroethylene sheathed	stainless steel dia. 44.5 × 2.5 or 48.3 × 3.6* with PTFE-liner	St 37, sealing strip of PTFE
BM 24/N-AI Aluminium clad	stainless steel dia. 43 × 1.5 with aluminium tube dia. 50 × 3	St 37, aluminium clad
BM 24/.../B Heated (special version, "B" indicated in 5th position of type code)	stainless steel dia. 60 × 2 and dia. 44.5 × 2.5 or 48.3 × 3.6 (double-walled for heating)*	

* only with connection flange \geq DN 80

BM 24

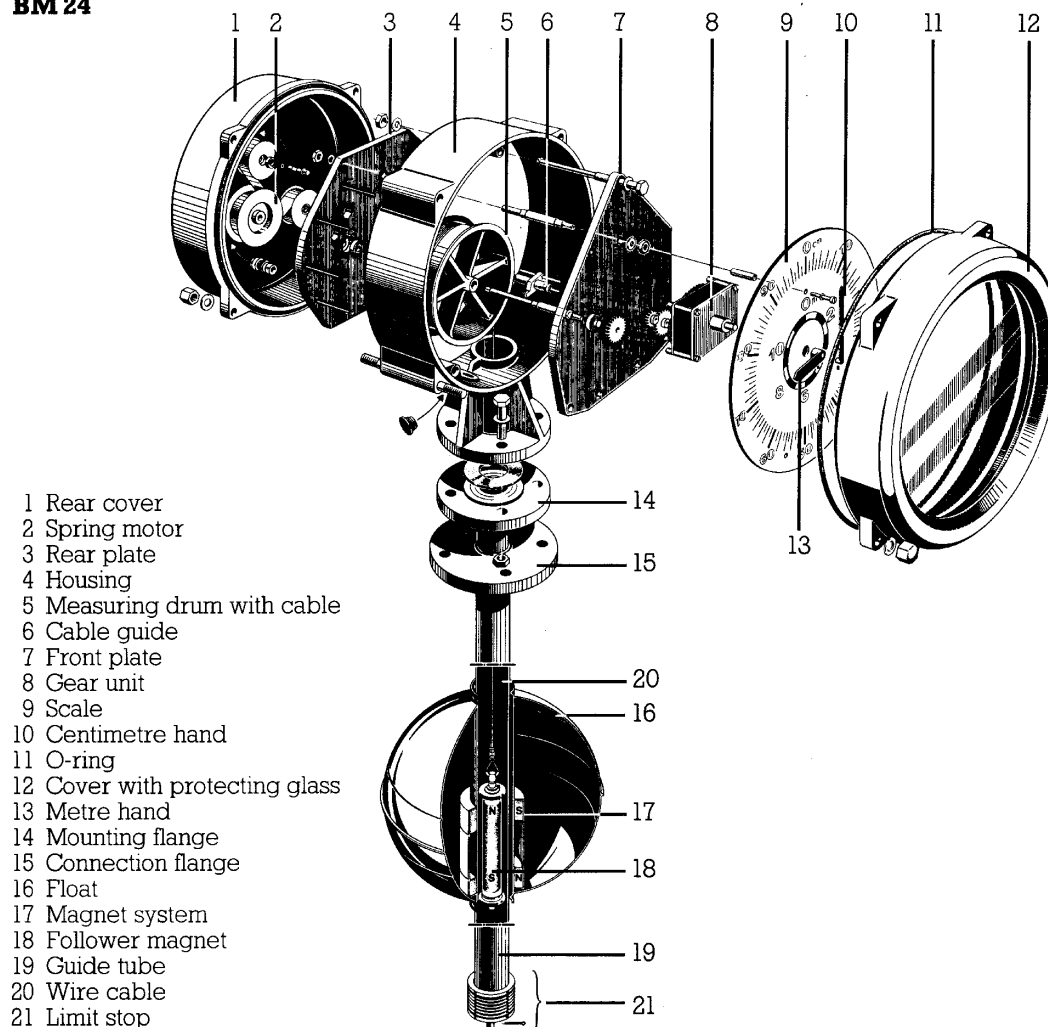

8. Float selection

No.	Shape	Dimensions (mm)	Material	Operating conditions					
				Max. operating pressure bar (MPa) at 20 °C		Temperature range °C min. max.		Min. density kg/l	Stock number
1	Ball	dia. 297 × 1.5	stainless steel 1.4571	19	(1.9)	- 60	+ 400	0.43	2.01150.00
2	Ball	dia. 297 × 1.5	stainless steel 1.4541	19	(1.9)	- 160	+ 400	0.43	
3	Ball	dia. 297 × 2.0	stainless steel 1.4571	30	(3.0)	- 60	+ 400	0.55	2.1151.0000
4	Ball	dia. 297 × 2.5	stainless steel 1.4571	40	(4.0)	- 60	+ 400	0.6	2.1151.0200
5	Ball	dia. 297 × 2.0	Hastelloy-C4	19	(1.9)	- 200	+ 400	0.55	2.01151.0300
6	Ball	dia. 304 × 1.5	stainless steel hard rubber coated	19	(1.9)	- 15	+ 80	0.55	8.01893.0100
7	Ball	dia. 255 × 2.0	titanium	25	(2.5)	- 60	+ 250	0.45	2.03937.0000
8	Cylinder	dia. 170 × 230	hard glass	6	(0.6)	- 50	+ 200	0.8	2.03665.0000
9	Cylinder	dia. 185 × 210	PTFE solid, bonded with PFA	5	(0.5)	- 200	+ 200	0.75	8.09344.0000
10	Cylinder	dia. 210 × 250	PVC	6	(0.6)	- 40	+ 60	0.6	8.02547.0200
11	Cylinder	dia. 210 × 250	polypropylene	6	(0.6)	+ 10	+ 60	0.5	8.02547.0201
12	Cylinder	dia. 166 × 210	PVDF bonded	5	(0.5)	- 40	+ 150	0.7	8.09336.0000

Product pressure, temperature and density will determine choice of float. The material of construction must also be suitable for the application. Technical data of other floats available on request.

Float shapes

The graphs show the depth of immersion "h" vs. product density for each float type.

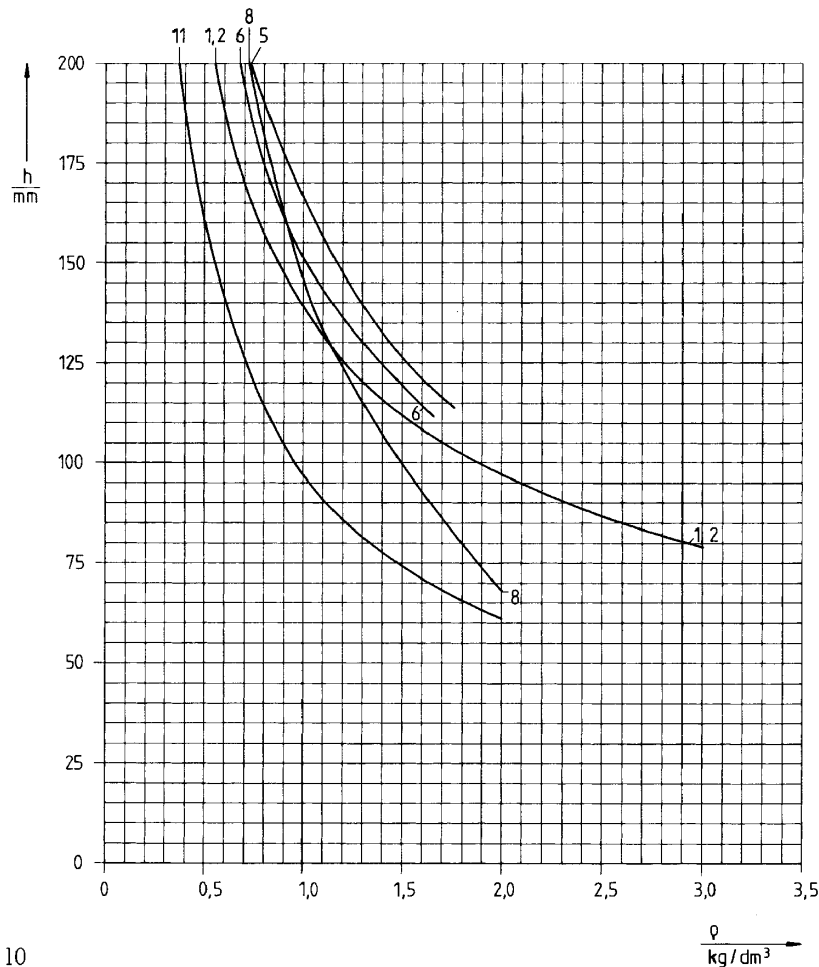

1, 2, 3, 4, 5

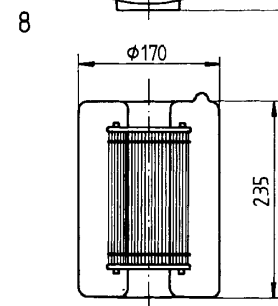
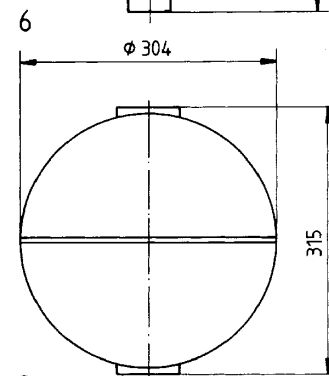
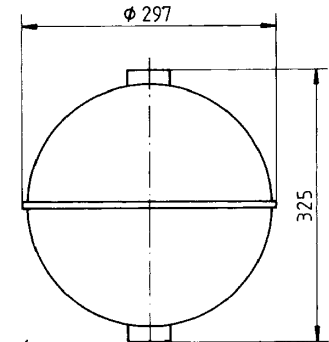

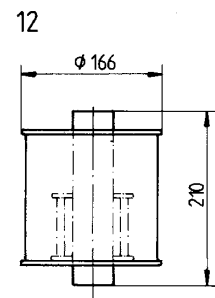
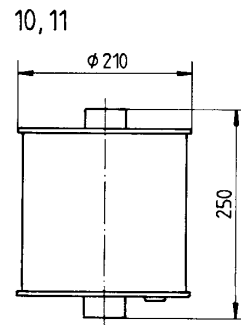
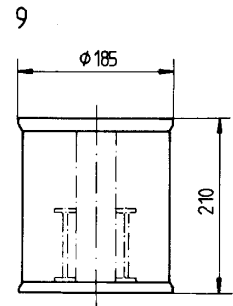
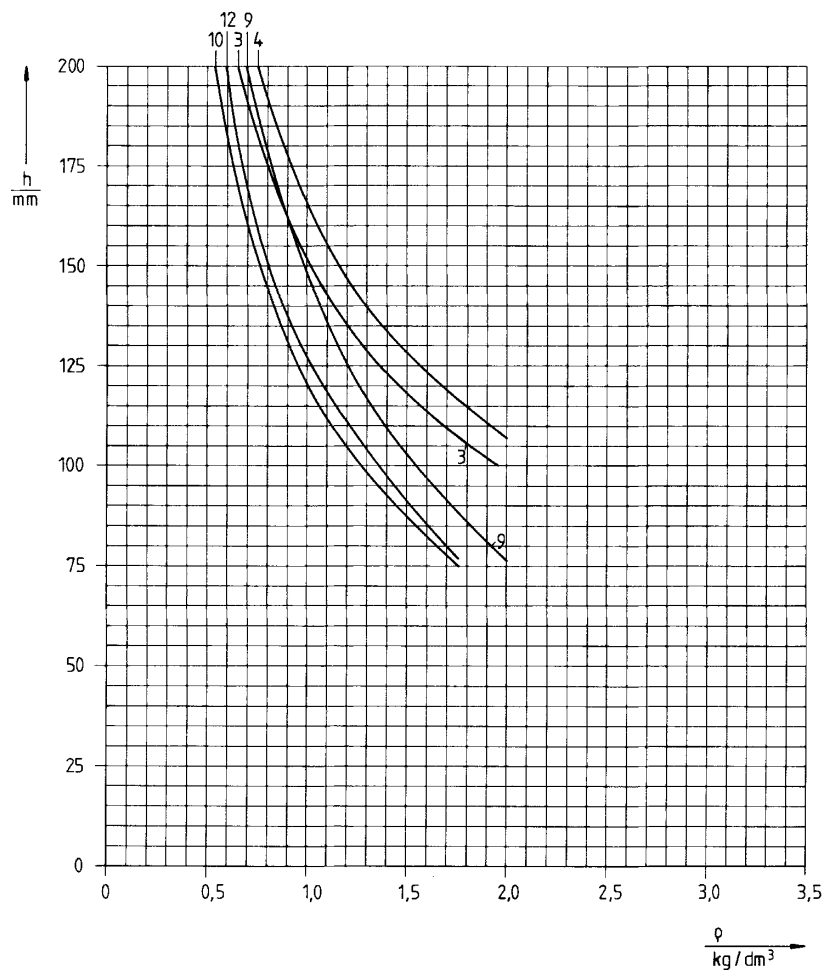

9. Technical data

Instrument type	BM 24 level gauge
Measuring range	max. 18 m
Product	Liquids, incl. liquefied gases
Viscosity	≤ 100 mPa·s
Solids	≤ 100 g/l
Particle size	≤ 200 μ m dia.
Accuracy	± 2 mm of measured value
Operating data	
Max. pressure	16 bar, special version: 40 bar
Product density	0.4 to 3.0 kg/l
Ambient temperature	-60 °C to +120 °C Special version: -160 °C to +400 °C Note restrictions imposed by built-in options!
Indication	
Design	Circular scale, 280 mm dia.
Scale marks	(m) and (cm), special version: (m ³) or (%) marks
Connection	
Standard	Flange DN 50, PN 16, dimensions to DIN 2527
Special version	other DN, flanges to DIN 2512 and other standards
Housing	
Material	Cast aluminium
Protection category to DIN 40050	IP 56