



OPTIMASS MFC 010 Converter

- For both OPTIMASS and OPTIGAS flowmeters
- For direct measurement of mass flow rate, density and product temperature
- MODBUS protocol
- Software version 2.11

1. Introduction	5
2. Mechanical Installation	5
3. Electrical Installation	6
3.1 Electrical Input Specifications for the MFC010	6
3.2 Recommended Cable Specification	7
3.3 Connection to the MFC010	8
3.4 Connection to the Modbus Bus	10
3.5 Installation Guidelines for Electromagnetic Compatibility	12
4. Installation in Hazardous Area Applications	13
4.1 Power Supply Barrier Devices	15
4.2 Modbus Barrier Devices	16
4.3 Connection To The Modbus Bus	17
5. Modbus Protocol Interface	19
5.1 Character Transmission Format	19
5.2 Modbus Telegram Format	20
5.3 Data Types in Modbus	20
5.4 Multidrop Operation	21
5.5 Calculating Data Transmission Rates	21
5.6 Error Messages in Modbus	22
6. Modbus Functions Supported by the MFC010	23
6.1 01 (01 ₁₆): Read Coil Status	23
6.2 02 (02 ₁₆): Read Discrete Input	24
6.3 03 (03 ₁₆): Read Holding Registers	25
6.4 04 (04 ₁₆): Read Input Registers	26
6.5 05 (05 ₁₆): Force Single Coil	27
6.6 06 (06 ₁₆): Preset Single Register	28
6.7 07 (07 ₁₆): Read Exception Status	29
6.8 08 (08 ₁₆): Diagnostics	30
6.9 11 (0B ₁₆): Fetch Comm. Event Counter	30
6.10 16 (10 ₁₆): Preset Multiple Registers	31
6.11 17 (11 ₁₆): Report Slave ID	32
7. MFC010 Modbus Data Model	33
7.1 MFC010 Register Structure	33
7.2 Discrete Status Output "Coil" Registers	39
7.3 Discrete Input (Binary) Status Registers	41
7.4 Input Registers	43
7.5 Holding Registers	49
8. MFC010 Operations	71
8.1 Mass Flow Zero Calibration	71
8.2 Density Calibration	72
8.3 Fixed and Referred Density Operation	75
8.4 Concentration Measurement	76
8.5 Using the System Protection Passwords	76
8.6 Saving and Restoring Configuration settings	77
8.7 Implementing User Defined Units	77
8.8 Using the Internal Process Control Mechanism	78
8.9 Custody Transfer Applications	78
8.10 Pressure Suppression	79

9. Error and Warning Messages	81
9.1 System Errors	81
9.2 Process Warnings	85
10. Trouble Shooting	88
10.1 “No Response to Modbus Requests”	88
10.2 “Communication Errors”	88
10.3 “The MFC010 is responding with an Illegal Modbus Function Message”	89
10.4 “The MFC010 is responding with an Illegal Data Message”	89
10.5 “The MFC010 is responding with an Illegal Address Message”	89
Appendix A : Modbus CRC Checksum Calculation	90
Appendix B : Hexadecimal and Binary Notation	92
Appendix C : Decoding Floating Point Numbers	93
Single Precision Floating Point Numbers (“Floats”)	93
Double Precision Floating Point Numbers (“Doubles”)	94
Appendix D : Sensor Sizes and Associated Default Register Settings	95
Appendix E : Installation of Power Supplies in MFC010 Applications	97
Appendix F: MFC010 Toolbox	100

Product Liability and Warranty

The MFC010 mass flow sensor electronics are an integral part of the OPTIMASS and OPTIGAS mass flowmeter families designed for the direct measurement of mass flow rate, product density and product temperature, and also indirectly enables the measurement of parameters such as mass total, concentration and volume flow.

When used in hazardous areas, special codes and regulations are applicable which are specified in the section on Hazardous area applications in this document. Please note that hazardous area approved meters must ALWAYS be connected using appropriate barriers, even when used outside the hazardous area, else the approval is void.

Responsibility as to suitability and intended use of the equipment rests solely with the purchaser. KROHNE does not accept any liability resulting from misuse of the equipment by the customer.

Improper installation and operation of the flow meters may lead to loss of warranty. Warranty is also null and void if the instrument is damaged or interfered with in any way.

In addition, the "General Conditions of Sale", which form the basis of the purchase agreement, are applicable.

If you need to return OPTIGAS or OPTIMASS flow meters to KROHNE, please complete the form on the last page of the Sensor manual and return it with the meter to be repaired. KROHNE regrets that it cannot repair or check returned equipment unless accompanied by the completed form.

Standards and Approvals



The MFC010 converter is tested and certified, when installed according to the directions contained in this document, to meet all of the requirements of the EU-EMC and PED directives and hence bears the CE symbol.



The MFC010 converter in association with the OPTIGAS and OPTIMASS sensor systems is approved for operation in Hazardous area installations according to the harmonized European Standards (ATEX).



Approvals for Hazardous area installations compliant with the FM and CSA standards are pending.

Copies of all of the certificates of conformity for the approvals listed above are available from the download centre of the KROHNE website at www.krohne.com.

THE CONTENT OF THIS DOCUMENT IS SUBJECT TO CHANGE WITHOUT PRIOR NOTICE.

1. Introduction

The MFC010 is a stand alone signal converter designed to directly interface the OPTIMASS and OPTIGAS families of Coriolis mass flowmeters into control systems using the Modbus RTU protocol where there is no requirement for the extensive output control features provided by more expensive converter solutions.

The MFC010 performs three primary direct measurements, Mass flow, Density and Temperature. Using these primary measurements the MFC010 is able to calculate an array of secondary values such as Volume Flow, Velocity and Concentration.

Mass Flow – Mass flow measurement doesn't come any simpler, once installed just perform a "Zero Calibration", "Reset" the "Totalisers" and away you go. Where Process noise is a nuisance use the "Measurement Time Constant", "Low Flow Threshold" and "Pressure Suppression" features to provide reliable and repeatable results.

Density – Using the inverse relationship between the Density of the process product and the oscillation frequency of the measuring tube, the MFC010 can provide a very accurate and reliable Density reading. In order to maximise the excellent performance of the MFC010 the user should perform a density calibration after installation. The MFC010 provides two forms of Density Calibration, the simple "Single Point Calibration" and the more accurate "Two Point Calibration". Using the "Density Averaging" feature the user can reduce noisy readings caused by process installation and noise. **NB.** Density measurement is not available with the OPTIGAS 5000 meters.

Concentration – Using the "Density" and "Temperature" measurements the MFC010 is capable of calculating the concentration of a product in the process medium, from one of a number of pre-defined industry standards, such as "°Brix" and "°Baumé", as well as user defined mixtures using the programmable coefficients. Concentration measurement is a function that comes with a comprehensive manual and a Coefficient calculation software package which will take the users own process data and convert it into compatible coefficients to permit the MFC010 to automatically calculate the concentration of the target process.

Velocity – Using the measured mass flow and density, the velocity of the product is calculated using the "Pipe Diameter" setting. By default this is set to the measuring tube internal diameter to calculate the velocity of the product passing through the sensor, but it can be set to calculate the velocity in a section of the connecting pipe work.

Process Control – Where precise process conditions are required, the "Process Control" function can be used to detect adverse variations in the "Density" or "Temperature" measurements and, as well as indicating the condition, it can take one of a number of predefined actions according to the users requirements.

2. Mechanical Installation

Refer to the installation guidelines and instructions for mounting the sensor in the process pipe work provided in the handbook on the CD supplied with the sensor.

3. Electrical Installation

The MFC010 is provided with four electrical terminal connections.

- V+ The power supply input terminal.
- V- The power supply return path and “Common” for the Modbus interface.
- A The inverting (RS485-) terminal for the Modbus interface.
- B The non-inverting (RS485+) terminal for the Modbus interface.

These terminals can be accessed in the terminal compartment of the sensor.

3.1 Electrical Input Specifications for the MFC010

NB all voltages, unless otherwise stated, are with reference to the “V-“ terminal.

V+ Terminal

Min. Input Voltage	11.4V DC
Max. Input Voltage	12.6V DC
Max. Input Current	200mA DC

A & B *

Min. Input Voltage	-7V DC
Max. Input Voltage	+11.8V DC
Min. Output Voltage	-6V DC
Max. Output Voltage	+6V DC

*The Modbus protocol requires that the communications interface to the MFC010 complies with the limitations of the EIA/TIA-485 (RS485) specification.

For a standard, non hazardous area, sensor the input impedance of the MFC010 is equivalent to 1/8 of a standard RS485 load, i.e. an input impedance of $>96k\Omega$, permitting it to be connected to the Modbus bus in accordance with the Modbus requirements. However, when installed in a Hazardous area the MFC010 requires that suitable barrier devices must be fitted between the MFC010 and the Modbus main bus, see sections 4.1 & 4.2 for details of suggested barrier devices and connection. If the main Modbus Bus is configured for multidrop operation, a Modbus compatible RS485 repeater is required to connect the barrier devices to the bus, see section 4.3 for further details.

3.2 Recommended Cable Specification

The cable used to connect the MFC010 to the Modbus master control system should be an overall screened twisted pair cable, with two twisted pairs of a minimum 20 AWG conductor. The total cable capacitance should not exceed 50nF and the conductor inductance should not exceed 200µH. The external cable insulation should be specified appropriately for the environment into which the device is to be installed. The outside diameter of the cable should be between 6.5 mm and 9.5 mm to ensure proper sealing is achieved when passed through the cable gland entry.

KROHNE can supply suitable cable that can be ordered to the required length, the part numbers are as follows

External Insulation Colour Grey - KROHNE Part No. X5871059989

External Insulation Colour Blue - KROHNE Part No. X5871069989
(For hazardous area installations)

The maximum cable length from the MFC010 to the bus "Master" device is 300m when using the default Modbus transmission speed of 19200 Baud. There are further limitations on the cable length when installing the system into a Hazardous area, refer to section 4.3 on page 17 for details.

3.3 Connection to the MFC010

OPTIMASS meters:

1. Unscrew the fixing screw on the junction box cover.
2. Release the two fixing screws holding the cable grip in place and remove the grip.
3. Strip approx. 50mm/2" of the outer casing of the signal cable.
4. Split the screen away from the cores and fold it back on the outer cable.
5. Fit the cable grip and secure, making sure that the screen is gripped under the grip.
6. Connect the four cores to the terminals marked A,B, 12V, - as shown

NOTE: The spring loaded connections are released by depressing the white lever above each connection

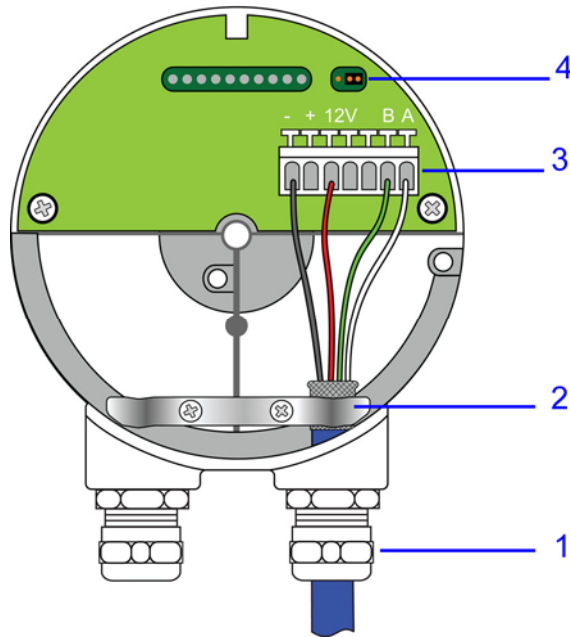

- 1 Cable Gland
- 2 Cable Grip/Earth
- 3 Terminal connections
- 4 Jumper for EOL resistor – off in position as shown, on in other position

Terminal	Input Connection
12V	V+
-	V-
A	A (RS485-)
B	B (RS485+)

OPTIGAS 5000:

The incoming cable must be passed through the cable gland entry on the side of the sensor stem. NB on the OPTIGAS meters the cable gland entry is located on the top of the stem cap. Remove the insulation from the cable as indicated below, ensuring that the screen of the cable is in direct (electrical) contact with the spring washer as indicated. **NB** On the some foil screened cables the outer surface of the foil screen may be coated in plastic, the user should therefore ensure that the screen is making good electrical contact with the gland by folding back the foil and drain wire. The length of the unshielded signal wires inside the terminal compartment must be kept to an absolute minimum as far as is practical.

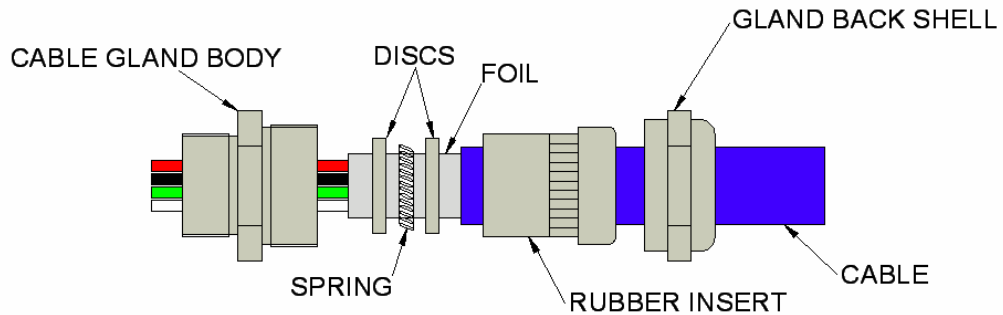

Connect the incoming power and signal wires as indicated in the following table. In order to achieve the stated system noise immunity, the twisted pair conductors should be connected with relation to their function i.e. the V+ and V- signals connected as one pair and the A & B signals connected as the second pair. This will greatly improve the system immunity to common mode noise sources (see also section 3.5, on page 12, for more information on interference and immunity to noise).

Terminal Number	Input Connection
1	V+
2	V-
4	A (RS485-)
5	B (RS485+)
Cable Gland	Cable Screen

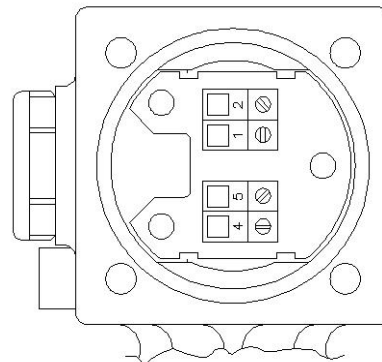

NB. When using foil-screened cable, the integral drain wire should not be relied upon to provide a secure ground connection to the foil screen. The foil screen must be terminated directly to a robust Earth point at both ends of the cable, on the MFC010 using the EMC cable gland provided.

3.4 Connection to the Modbus Bus

The MFC010 is designed to be connected as a Slave device onto the 2-wire bus implementation of the Modbus physical layer definition. In this configuration the receiver and transmitter lines for each device are connected together, Transmitter A to Receiver A and Transmitter B to Receiver B, and operated in Half Duplex mode, where the master transmits a request and only after receiving it does the nominated slave device transmit a reply. When not responding to a direct request from the Master device, the Slave devices remain passive, monitoring the bus and awaiting a suitable request from the Master device. In addition to the A and B signal lines the bus MUST include a "Common" signal line to act as a ground reference point for the A and B signals.

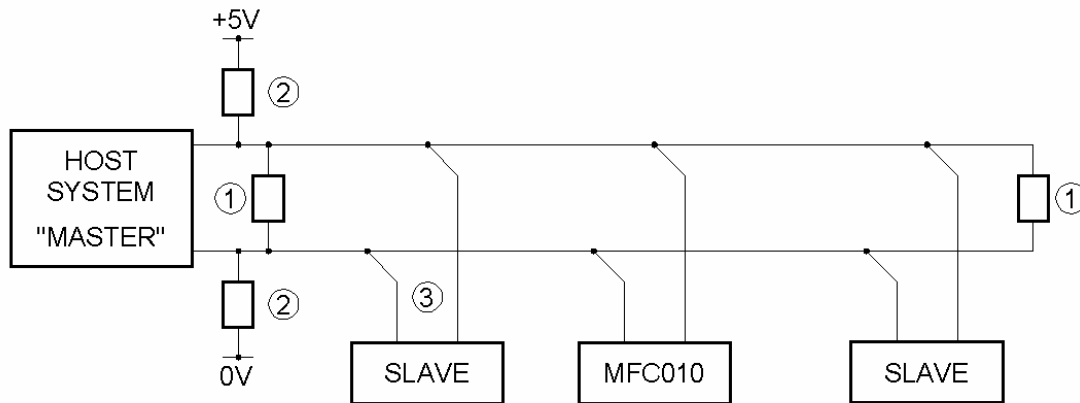

① The master bus must be terminated at its physical end points by suitable termination networks connected between the A (D0) and B (D1) signal lines. When not using bus-biasing resistors, see next paragraph, each termination network may consist of a single 150 Ohm, 0.5W resistor. However, when bus-biasing resistors are required, a more suitable termination network would consist of a 1nF capacitor in series with a 120 Ohm, 0.25W resistor. NB It is common that the Host system "Master" is physically at one end of the bus, so one of the termination resistors is fitted at its terminals, but it should be realised that this is not always the case and care should be taken to ensure that the termination network is at the physical end of the bus. In a point-to-point configuration, when only one Slave device is fitted to the bus, then the terminating networks can simply be situated at the connecting terminals of the master and slave devices.

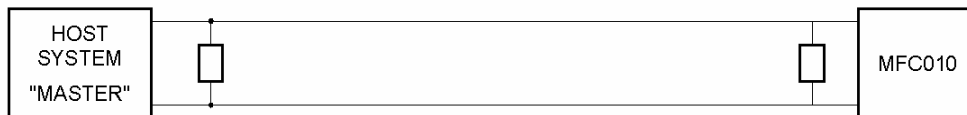

② Some slave devices require that Bus-Biasing resistors are fitted to ensure that the bus is in a defined state when none of the transmitting devices are active. The MFC010 does NOT require Bus-Biasing resistors to be fitted but is compatible with their presence on the bus if one or more of the other slave devices on the bus require them to be fitted, as long as they comply with the Line Polarization requirements of the Modbus specification.

③ In a multidrop bus configuration the slave devices are connected to the main bus cable by branch connections at intervals along the length of the main bus. The branch connections, Derivations as they are termed in the Modbus specification, must be less than 20m in length from the main bus cable to the slave device. Some slave devices permit direct connection to the main bus, known as "Daisy Chaining", in some cases by providing extra terminals and cable access points. However, as indicated in the previous sections, access to the terminal compartment of the MFC010 is limited; therefore it is not practical to directly connect the MFC010 to the main bus. Instead, the installation should utilise a short branch connection. If a greater length of cable is required between the MFC010 device and the main Modbus bus, the user should install a suitable RS485 repeater between the MFC010 and the bus (refer to the diagram below).

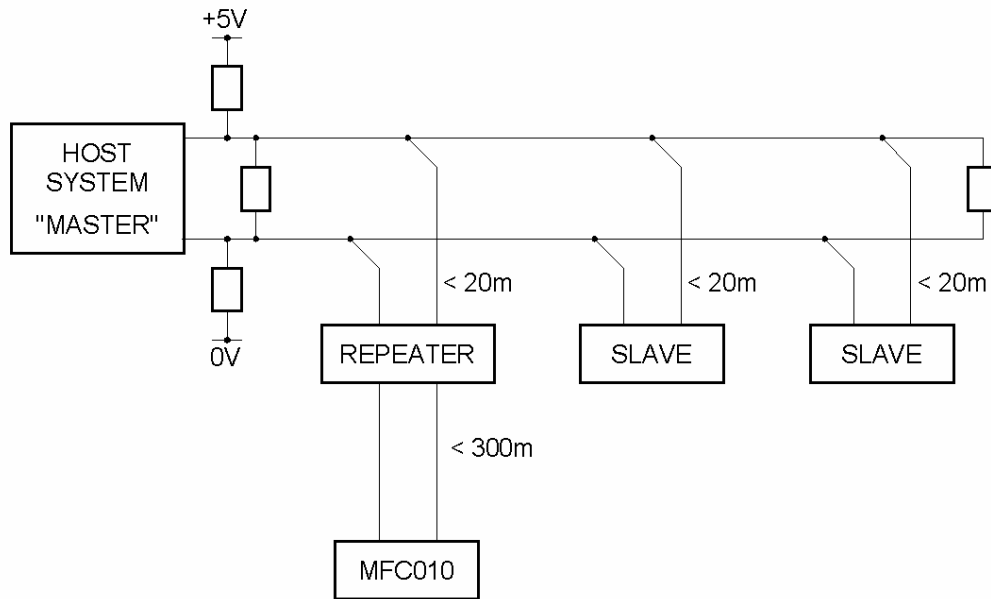

Because the connection to the bus requires exposing the signal wires, the connection to the main bus should be made within a suitable EMI shielded enclosure. This connection should include the “Common” signal connection, the power supply connection (if a suitable one is provided by the bus), and the drain wire when available. Each of the cable screens must be properly terminated to the enclosure by means of appropriate EMC cable glands. For example:

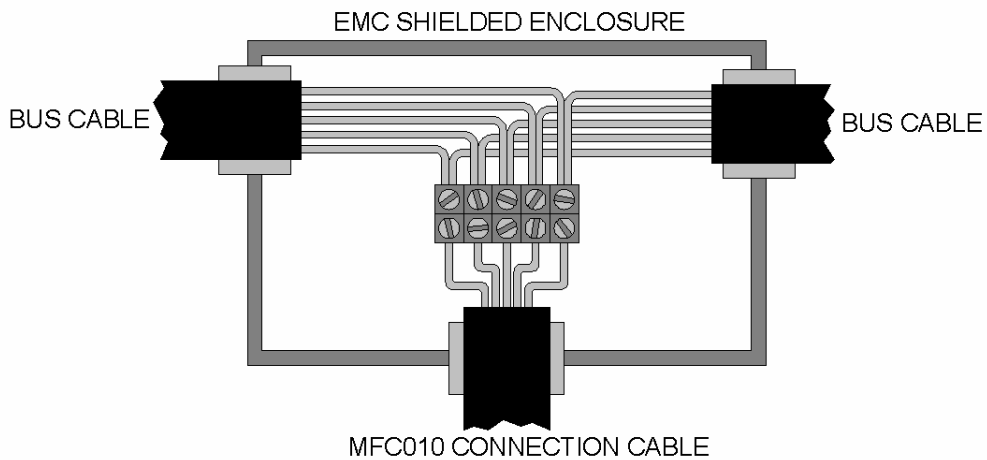

If the Bus does not provide a suitable power supply for the MFC010, a separate suitable power supply connection should be made at this point.

An RS485 Repeater can be used to extend the length of the Bus and the number of slave devices that are attached to the bus (refer to the figure below). However, if the bus is extended in such a fashion, termination and polarization networks should be fitted according to the same rules as used for the main bus (see descriptions above).

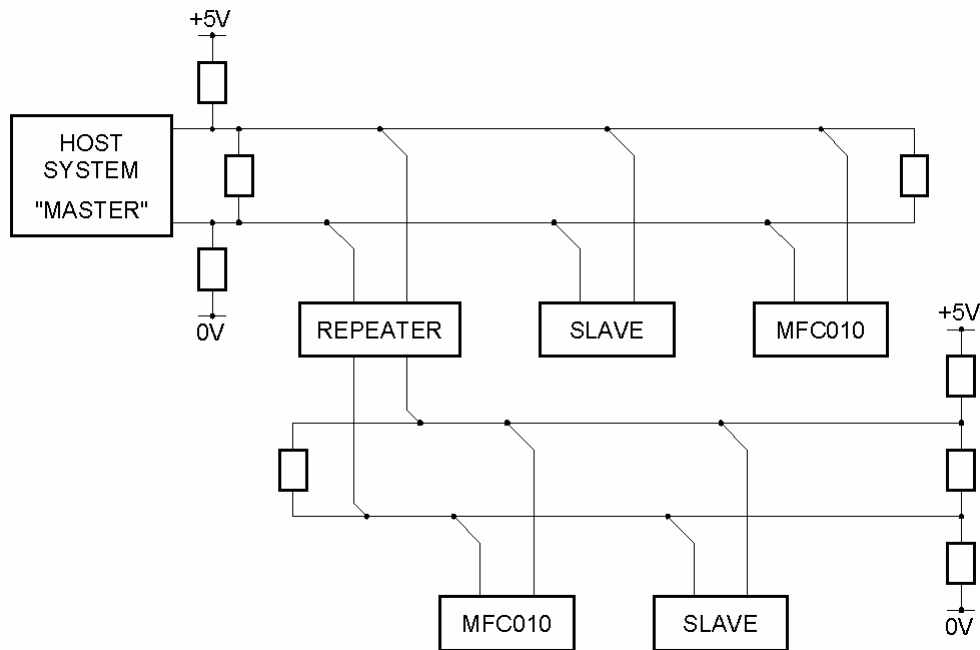

NB For Hazardous Area applications the user should refer to section 4.3, on page 17, for connection details.

NB For multidrop systems, ensure cycle times are properly calculated to ensure bus speeds are adequate for the application.

3.5 Installation Guidelines for Electromagnetic Compatibility

Whilst the MFC010 and its associated sensor has been designed, tested and certified to meet the requirements on international standards of Electromagnetic Compatibility (EMC), it is the users responsibility to ensure that the connection guidelines described in this document are followed. In addition the user should use recognised good practise in the location and cable routing of the MFC010 in relation to its surrounding environment. The user should consider the following suggestions when installing an MFC010 into a system.

1. Every effort should be made to avoid significant lengths (>50mm) of unshielded signal wire when connecting to the system, any terminal connections should be housed in a suitably shielded enclosure.
2. Avoid routing the cable in groups with or alongside other power carrying cables.
3. Avoid locating the MFC010 or routing the connection cable in close proximity to large electrically powered equipment, such as pumps, inverters etc.
4. If necessary, route the connection cable through a suitably earthed metal conduit.

4. Installation in Hazardous Area Applications

Before installation the user MUST ENSURE that the equipment to be installed is the Hazardous area approved equipment.

Copies of the appropriate certificates can be found on the KROHNE website at www.krohne.com.

Before installation the user MUST refer to the hazardous area installation document, supplied with this equipment, and strictly adhere to the relevant installation instructions indicated therein.

When the MFC010 is used in Hazardous area installations, suitable barrier devices MUST be fitted. The Safety Parameters for the MFC010 are as follows. All interface and barrier devices must be appropriately certified to meet these parameters.

V+ & V-	Input Voltage, U_i	16.5V
	Input Current, I_i	340mA
	Input Power, P_i	1.3W
	Input Capacitance, C_i	25nF
	Input Inductance, L_i	10 μ H
A & B	Input Voltage, U_i	11.8V
	Input Current, I_i	40mA
	Input Power, P_i	120mW
	Input Capacitance, C_i	25nF
	Input Inductance, L_i	10 μ H

The output safety parameters of the barrier devices must not exceed the Voltage, Power and Current limits set out above. The output Capacitance parameter for the barrier devices must exceed the sum of the MFC010 input Capacitance, specified above, and the maximum cable Capacitance. The output Inductance parameter for the barrier devices must exceed the sum of the MFC010 input Inductance, specified above, and maximum cable Inductance. To summarise:

$$\begin{array}{llll}
 U_o \text{ Barrier} & < & U_i \text{ MFC010} \\
 I_o \text{ Barrier} & < & I_i \text{ MFC010} \\
 P_o \text{ Barrier} & < & P_i \text{ MFC010} \\
 C_o \text{ Barrier} & > & C_{\text{cable}} + C_i \text{ MFC010} \\
 L_o \text{ Barrier} & > & L_{\text{cable}} + L_i \text{ MFC010}
 \end{array}$$

NB The In-line resistance of the Modbus barrier **MUST NOT EXCEED** 1000 Ohms for each of the A and B Input terminals.

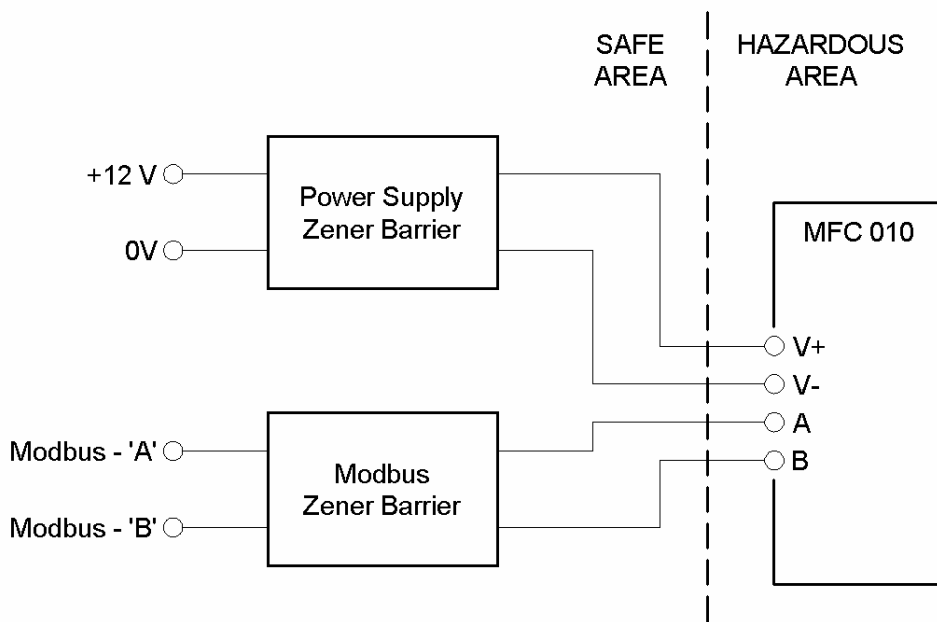

The Zener barrier devices must be installed in an EMI shielded enclosure and the cable screen(s) kept intact right up to the barrier terminals as far as is practical. The cable screen(s) should be terminated to the enclosure, chassis Earth connection, and kept SEPARATE from the intrinsically safe Earth connections of the Barrier devices. The user MUST adhere to the barrier manufacturer's instructions for connecting the intrinsically safe Earth connection to the barrier devices.

4.1 Power Supply Barrier Devices

The following Zener Barrier devices are those that are recommended for use on the V+ & V- power supply input connections to the MFC010.

Manufacturer : Bartec
 Part Number : 17-1834-1000/3715
 Ex Approvals : EEx ia/ib IIC

Connection :

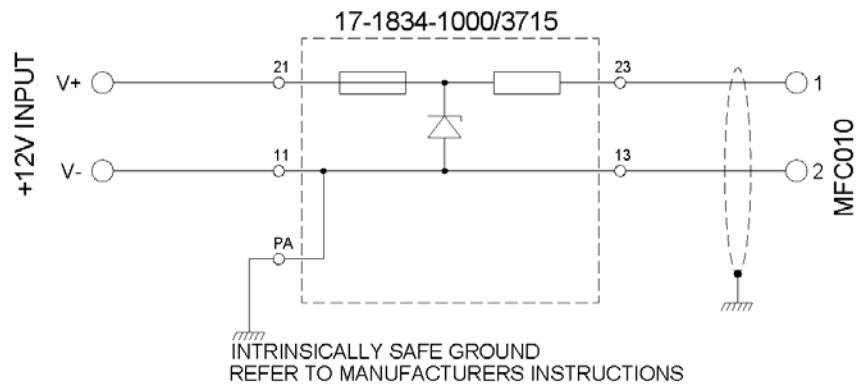

Manufacturer : Pepperl & Fuchs
 Part Number : Z765
 Ex Approvals : EEx ia IIC
 FM and CSA Approved

Connection :

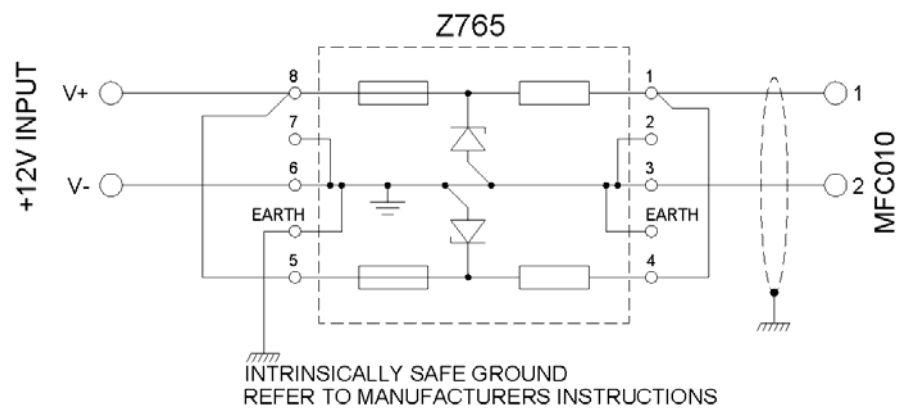

4.2 Modbus Barrier Devices

The following Zener Barrier devices are those that are recommended for use on the A & B Modbus input connections to the MFC010. When specifying alternate devices the user must ensure that the in-line resistance of the Modbus barrier **DOES NOT EXCEED** 1000 Ohms for each of the A and B Input terminals.

Manufacturer : Bartec
 Part Number : 17-1834-4000/0031
 Ex Approvals : EEx ia/ib IIC

Connection :

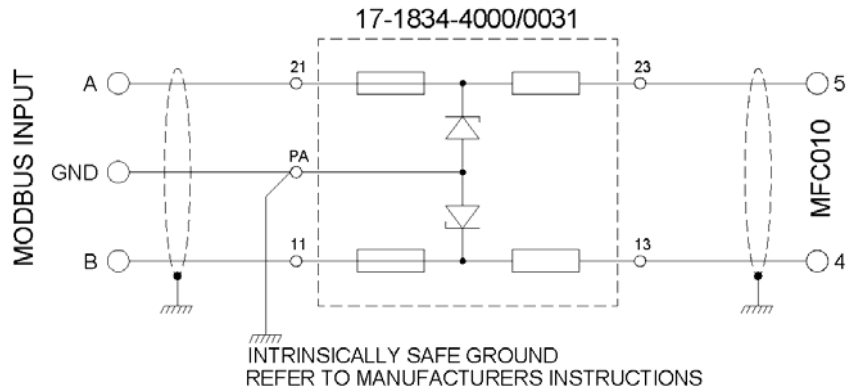

Manufacturer : Pepperl & Fuchs
 Part Number : Z764
 Ex Approvals : EEx ia IIC
 FM and CSA Approved

Connection :

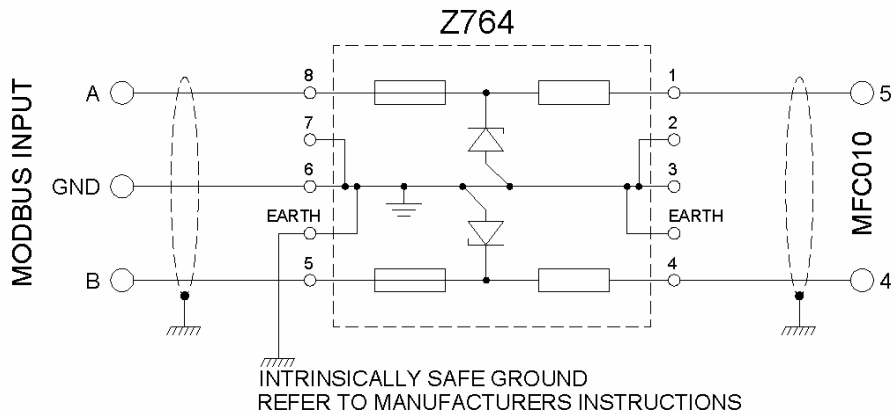

4.3 Connection To The Modbus Bus

When installed in hazardous area application the MFC010 interface is not directly compatible with the Modbus interface standard due to the presence of the required Zener Barrier devices.

In a point-to-point configuration, when the MFC010 is the only device on the bus, the cable length from the barriers to the "Master" host system must not exceed 10m in length. If a greater distance is required, the use of a suitable RS485 repeater is recommended, in which case the repeater connection to the Zener Barrier devices should not exceed 10m in length. The maximum cable length between the Repeater and the "Master" host system is determined by the operating limits of those two devices. The cable length from the Modbus barrier device to the MFC010 must be less than 300m i.e.

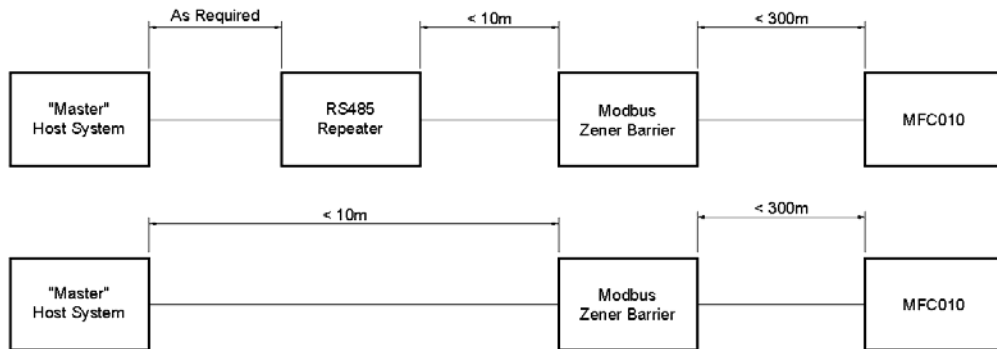

Where the distance from the barrier device to the MFC010 is less than 10m, two barrier devices may be connected in parallel to the "Master" host system, or the repeater if one is being used, refer to the diagram below. The overall cable length from the Host/repeater to the barrier devices must still be less than 10m as described previously. If more than two devices are required to be connected then a dedicated repeater should be used for each.

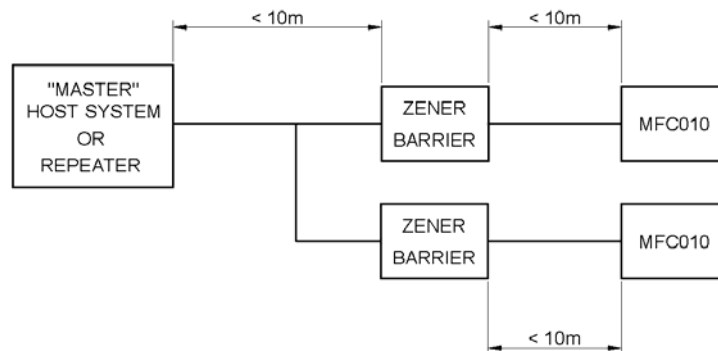

Each MFC010 MUST have its own dedicated barrier interface; they MUST NOT be connected in parallel on the hazardous area side of the system.

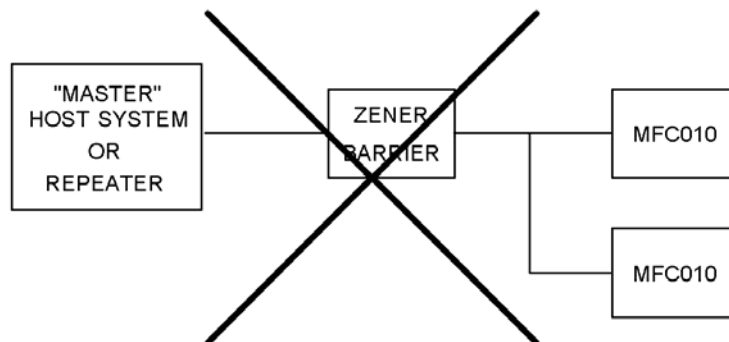

In a multidrop installation, see figure below, the Zener Barrier devices must be connected to the bus using a suitable RS485 repeater, with the connecting cable between the Barrier devices and the repeater not exceeding 10m. The connection of the repeater to the Modbus bus must then follow the rules and restrictions of the Modbus protocol as indicated previously in section 3.4.

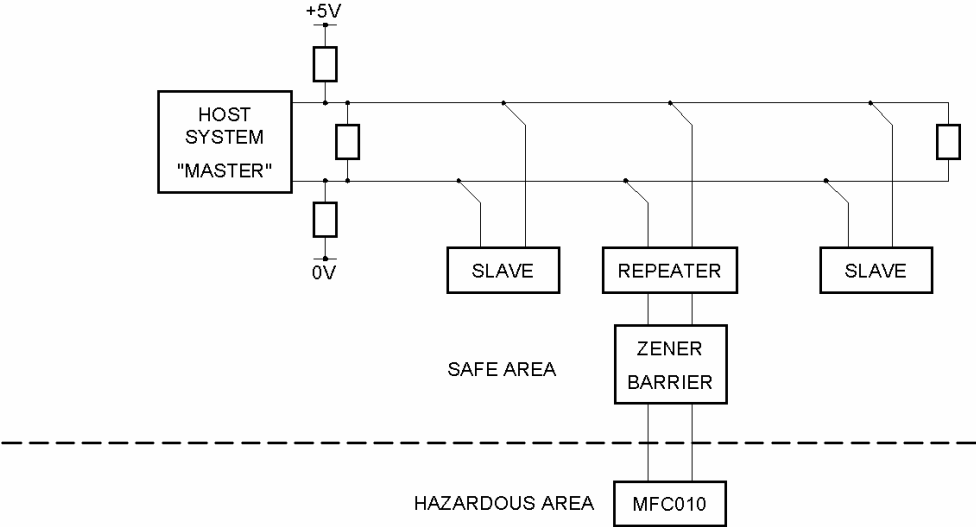

5. Modbus Protocol Interface

The interface to the MFC010 is implemented in the Modbus RTU communications protocol, and is done so in accordance with the specification and requirements of the "Modbus Protocol Reference Guide" (PI-MBUS-300 Rev J). The physical electrical parameters of the Modbus specification are defined by the EIA/TIA-485 (RS485) standard and the "Modbus over Serial Line - Specification and Implementation Guide V1.0" interface definition.

In a serial communications system such as the Modbus protocol, data is transmitted as a series of voltage levels along the connecting data wires. A "bit", or binary digit, value is determined by the logical level (high or low) of the connecting interface over a set time period. The time period for each bit is determined by the transmission speed, known as the baud rate. For a baud rate of 9600, the bit period is $1/9600 = 104.2$ microseconds. The MFC010 supports Baud rates of 1200, 2400, 4800, 9600, 19200, 38400 and 57600 baud (see the Baud rate setting in Holding Register No. 1005). The higher transmission speeds require careful attention to the cable installation in order to function reliably and error free (see Section 3.2 on page 7 for installation details).

5.1 Character Transmission Format

Data is transmitted in sets of 8 bit data blocks, known as "Bytes" or "Characters". Each character is preceded and followed by framing bits that permit the correct detection of the transmitted character. The first "Bit" transmitted will be the "Start" bit, this permits the receiving device to detect that a character is being transmitted. The "Start" bit is then followed by the 8-bit data byte. A "Parity" bit may then follow the 8-bit character. This "Parity" bit is optional (see the Transmission format setting in Holding Register No. 1004), it allows the system to validate the contents of the 8-bit data byte to ensure that no errors have occurred during transmission. Following the "Parity" bit is the "Stop" bit that indicates the end of the transmitted character to the receiving device. If no parity bit is used, two stop bits must be implemented, this ensures a consistent character length of 11 bits is maintained.

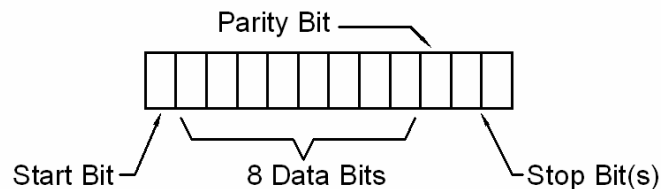

The 8 data bits are annotated from bit 0 (the least significant bit, LSB) to bit 7 (the most significant bit, MSB). The character is transmitted "MSB first", i.e. the first bit after the start bit, is bit 7 of the data byte. See appendix B for more details on binary coding.

5.2 Modbus Telegram Format

The messages between the Modbus master and slave devices are transmitted as groups of characters, as described above, collectively known as telegrams. Each telegram is preceded and followed by a “Quiet” period on the Modbus bus of $3\frac{1}{2}$ character periods. The “Quiet” period following the telegram is used to indicate the end of the telegram.

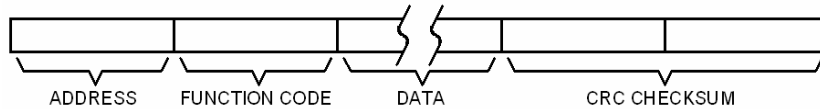

The first character received in the telegram identifies the slave device to which or from which the telegram is being transmitted. This first character is known as the Slave ID or Slave Address. In multidrop configurations (see Section 5.4 below) this address character is used by the master device to individually communicate with one of the instruments on the bus connection. The Slave device returns this value to indicate to the master the source of the response telegram. The Slave Address value for the MFC010 can be set using Holding register No. 1006 (see Section 7.5).

The second character received in the telegram is the function command code requested by the master device. A list of the function codes supported by the MFC010 can be found in Section 6 (See Page 23) along with a description of each.

The last two characters received form a 16-bit checksum value. This checksum value is used to ensure that the data received in the telegram has not been corrupted. The checksum is calculated and appended to the telegram by the transmitting device (Slave or Master) and the receiving device compares the received checksum value against the value it calculates from the received data. If the data has been corrupted in some way during transmission, then the checksum calculated by the receiving device will be different than that which it received with the telegram. The receiving device will then ignore the telegram knowing that the data within is unreliable. See Appendix A for information on the Modbus Checksum calculation.

Between the function code character and the CRC checksum at the end of the telegram is the telegram data. The contents and format of these data characters is dependant upon the function code requested.

5.3 Data Types in Modbus

There are two data types used to transmit information on a Modbus data bus, the “Bit” and the “Register”. The “Bit” represents a single binary state, whether as an output or an input condition. The “Register” is a 16-bit integer transmitted as two 8-bit characters. Using multiple “Registers” the Modbus interface can transmit higher accuracy values such as “Floating Point” and “Double Precision Floating Point” numbers.

“Bit” variables are packed into 8 bit bytes, so each character sent or received can contain up to 8 “Bit” variables. The Master and Slave devices use only as many 8 bit data characters as are required to transmit the information. Any unused bits in the data characters are ignored. The bit that is first indexed by the Master request address is transmitted in the LSB, Bit 0, of the first data character. The next “Bit” value is transmitted in the next bit, Bit 1, of the first data character. This continues until the last bit location, Bit 7, of the first data character is used. The next “Bit” value is then transmitted in the LSB, Bit 0, of the following data character, this continues until all of the requested values have been transmitted. Any unused bit locations in the last data character are filled out with “0”s

For simple single register variables the Most Significant Character of the register is transmitted first, with the Least Significant character following immediately after. However, for variables that require multiple registers, i.e. the “Floating Point” and “Double Precision Floating Point” variables, the transmission order is a little more complicated. i.e.

Single 16 Bit Register Variables, Data Transmission Order

Byte 1, MS Byte	Byte 0, LS Byte
-----------------	-----------------

Long Integer & Floating Point Variables, Data Transmission Order

Byte 1	Byte 0, LS Byte	Byte 3, MS Byte	Byte 2
Requested Register		Requested Register + 1	

Double Precision Floating Point Variables, Data Transmission Order

1	0	3	2	5	4	7	6
Requested Register		Register + 1		Register + 2		Register + 3	

5.4 Multidrop Operation

A “Master” device, such as a PC or PLC, can be used to control and interrogate a number of “Slave” devices, such as an MFC010, connected to the Modbus bus in a “Multidrop” configuration. The “Master” device always initiates the communication interchange with the “Slave” devices, each of which waits for instructions or requests from the “Master” before transmitting data on the bus in response to the instruction. Although the Modbus specification allows for up to 247 “Slave” devices to be physically connected to the bus at any time, the Master device can only request information from one “Slave” device at a time. A unique ID number or “Address” is allocated to each of the “Slave” devices to allow the “Master” to differentiate between them. Although it does not matter in which order the “Slave” devices are interrogated, the “Master” must wait for the response, or for a suitable period after the request, before making a request to any other of the slave devices on the bus.

Under some limited conditions, i.e. when the instruction to the “Slave” device does not require a detailed response, the “Master” device can send a “Broadcast” command, indicated by a “Slave” ID Address of “0”, to all of the slave devices simultaneously.

5.5 Calculating Data Transmission Rates

Careful attention should be made to ensuring that the bus installation can support the amount and rate of data transmission required. Consideration of the limitations of the physical installation, as previously described, should not be ignored. The maximum usable transmission speed, baud rate, will depend entirely upon the installation.

The transmission format also needs to be carefully considered. In the Modbus standard, each transmitted character is 11 bits long, depending upon the setting of the transmission format. At the Modbus default transmission speed of 19200 baud, each character will have a transmission period of 573 microseconds.

For a simple data transfer of one Input value (see section 6.4 on page 26 for details) between the master and slave will require an 8 character (+ 2 x 3½ character “Quiet” periods) telegram in the request from the master, and a 9 character (+ 2 x 3½ character “Quiet” periods) telegram in the response from the slave. If the Slave responds immediately the cycle from the Master sending the request to receiving the response will be at least 31 characters long, or 17.8 milliseconds at 19200 baud. Therefore the maximum rate of data requests that could be made is 56 every second.

In most cases far more data will be required, and in multidrop systems the master device may be requesting data from up to 64 units. In these circumstances the user must ensure that there is sufficient time interval between requests for the measured values to be received without overlapping the Master request telegram with the previous slave reply telegram.

To achieve the required update rates the user may have to consider whether, in a multidrop configuration, the number of devices on a bus must be limited or whether the cable installation will support one of the higher data transmission speeds which are available.

This is especially important where fast response is required (such as batch filling operations).

5.6 Error Messages in Modbus

When the MFC010 detects an error in the request received in a properly formatted telegram, it will respond with an error message. The error message response telegram is formatted as follows.

Address	Function	Error Code	CRC	CRC
---------	----------	------------	-----	-----

The most significant bit of the requested function code is set (add 128, 80_{16}) in the response telegram to indicate that an error has been detected. For example, if an error were detected in a Function 1 request, then the returned function code would be 81_{16} (129).

The single data character in the response telegram will indicate the type of error detected. These are as follows.

1	Illegal Function	The requested function code is not supported by the MFC010 or is not valid due to the current settings of the device.
2	Illegal Data Address	The Register requested is not valid.
3	Illegal Data Value	The requested data (in Write operations only) is invalid for the register being written.
6	Slave Device Busy	The MFC010 is unable to process the requested command because an EEPROM save is in progress.

Errors due to communications faults (CRC errors, Parity errors etc) are logged but no response is returned because the data in the received telegram is deemed unreliable. The Master system can read the error logs by using the diagnostic command (Function 08, see Section 6.8).

6. Modbus Functions Supported by the MFC010

6.1 01 (01₁₆): Read Coil Status

This function permits the user to read the state of a number of consecutive Discrete Outputs, or “Coil”, registers. Within the MFC010 the majority of the Discrete Outputs are used to initiate command functions; when read, response will be “1” whilst command is being processed and “0” when the command is completed (See Section 7.2 on page 39 for details of the individual Status Output registers). The format of the Master request telegram for this function should be as follows.

Request Character	Field	For Example
1	Slave Address	01 ₁₆ Request to Slave ID 1
2	Function	01 ₁₆ “Read Coil Status”
3	Start Address Hi	03 ₁₆ rowspan="2">Start Address = 1002
4	Start Address Lo	E9 ₁₆
5	No of Points Hi	00 ₁₆ No. of Points = 5
6	No of Point Lo	05 ₁₆ (“Coils” 1002 – 1006)
7	CRC Lo	2D ₁₆ rowspan="2">CRC Checksum
8	CRC Hi	B9 ₁₆

The MFC010 will respond to such a request with a telegram formatted as follows.

Response Character	Field	For Example
1	Slave Address	01 ₁₆ Response from Slave ID 1
2	Function	01 ₁₆ “Read Coil Status”
3	Data Bytes in Response	01 ₁₆ 1 byte (5 States requested < 8 Bits)
4	Data Byte 1	15 ₁₆ Data = 0001010 ₂
5	CRC Lo	90 ₁₆ rowspan="2">CRC Checksum
6	CRC Hi	47 ₁₆

The number of data bytes in the response will depend upon the number of Discrete Outputs requested. The appropriate bit in each of the data bytes received will indicate each Discrete Output state requested. Therefore, each data byte in the response will contain a maximum of 8 Discrete Output “Coil” states. For example, if 19 Discrete Outputs are requested, then three data characters will be returned, with the first group of 8 output states encoded in the first data byte, the second group of 8 output states coded in the second data byte, and the last 3 output states coded in the first three bit locations of the last data byte. Bit 0 of the first response data byte will correspond to the “Start Address” Discrete Output register specified by the request telegram. Bit 0 of the second response data byte will correspond to the “Start Address” + 8 Discrete Output register and so on.

In the example above, 5 Discrete Outputs are requested, so only one data byte is required in the response. The response data value shown above indicates that registers 1002, 1004 and 1006 are active, and that registers 1003 and 1005 are inactive.

6.2 02 (02₁₆): Read Discrete Input

This function permits the user to read the state of a number of consecutive Discrete Input registers. (See Section 7.3, on page 41, for details of the individual registers). The format of the Master request telegram for this function should be as follows.

Request Character	Field	For Example	
1	Slave Address	01 ₁₆	Request to Slave ID 1
2	Function	02 ₁₆	“Read Discrete Input”
3	Start Address Hi	03 ₁₆	Start Address = 1001
4	Start Address Lo	E8 ₁₆	
5	No of Points Hi	00 ₁₆	No. of Points = 12 (“Inputs” 1001 – 1011)
6	No of Point Lo	0C ₁₆	
7	CRC Lo	F8 ₁₆	CRC Checksum
8	CRC Hi	7F ₁₆	

The MFC010 will respond to such a request with a telegram formatted as follows.

Response Character	Field	For Example	
1	Slave Address	01 ₁₆	Response from Slave ID 1
2	Function	02 ₁₆	“Read Discrete Input”
3	Data Bytes in Response	02 ₁₆	2 bytes
4	Data Byte 1	CD ₁₆	Data = 11001101 ₂
5	Data Byte 2	09 ₁₆	Data = 00001001 ₂
6	CRC Lo	2D ₁₆	CRC Checksum
7	CRC Hi	2E ₁₆	

The number of data bytes in the response will depend upon the number of Discrete Inputs requested. The appropriate bit in each of the data bytes received will indicate each Discrete Input state requested. Therefore, each data byte in the response will contain a maximum of 8 discrete input states. For example, if 19 Discrete Inputs are requested, then three data characters will be returned, with the first group of 8 input states encoded in the first data byte, the second group of 8 input states coded in the second data byte, and the last 3 input states coded in the first three bit locations of the last data byte. Bit 0 of the first response data byte will correspond to the “Start Address” Discrete Input register specified by the request telegram. Bit 0 of the second response data byte will correspond to the “Start Address” + 8 Discrete Input register and so on.

In the example above, 12 Discrete Inputs are requested, so two data bytes are required in the response.

6.3 03 (03₁₆): Read Holding Registers

This function permits the user to read the value of a number of consecutive Holding registers. (See Section 7.5 on page 49 for details of the individual registers). The format of the Master request telegram for this function should be as follows.

Request Character	Field	For Example	
1	Slave Address	01 ₁₆	Request to Slave ID 1
2	Function	03 ₁₆	"Read Holding Registers"
3	Start Address Hi	03 ₁₆	Start Address = 1023
4	Start Address Lo	FE ₁₆	
5	No of Points Hi	00 ₁₆	No. of Points = 3
6	No of Point Lo	03 ₁₆	(Input Registers 1023 – 1025)
7	CRC Lo	64 ₁₆	CRC Checksum
8	CRC Hi	7F ₁₆	

The MFC010 will respond to such a request with a telegram formatted as follows.

Response Character	Field	For Example	
1	Slave Address	01 ₁₆	Response from Slave ID 1
2	Function	03 ₁₆	"Read Holding Registers"
3	Data Bytes in Response	06 ₁₆	6 bytes (3 x 2 Byte Registers)
4	Data Byte 1	3F ₁₆	Register 1023 = 16201
5	Data Byte 2	49 ₁₆	
6	Data Byte 3	02 ₁₆	Register 1024 = 724
7	Data Byte 4	D4 ₁₆	
8	Data Byte 5	F1 ₁₆	Register 1025 = 61730
9	Data Byte 6	22 ₁₆	
10	CRC Lo	7D ₁₆	CRC Checksum
11	CRC Hi	BD ₁₆	

6.4 04 (04₁₆): Read Input Registers

This function permits the user to read the value of a number of consecutive Input registers. (See Section 7.5 on page 493 for details of the individual registers). The format of the Master request telegram for this function should be as follows.

Request Character	Field	For Example	
1	Slave Address	01 ₁₆	Request to Slave ID 1
2	Function	04 ₁₆	“Read Input Registers”
3	Start Address Hi	0B ₁₆	Start Address = 3001
4	Start Address Lo	B8 ₁₆	
5	No of Points Hi	00 ₁₆	No. of Points = 2 (Input Registers 3001 – 3002)
6	No of Point Lo	02 ₁₆	
7	CRC Lo	F3 ₁₆	CRC Checksum
8	CRC Hi	CA ₁₆	

The MFC010 will respond to such a request with a telegram formatted as follows.

Response Character	Field	For Example	
1	Slave Address	01 ₁₆	Response from Slave ID 1
2	Function	04 ₁₆	“Read Input Registers”
3	Data Bytes in Response	04 ₁₆	4 bytes (2 x 2 Byte Registers)
4	Data Byte 1	94 ₁₆	Register 3001 / 3002 = 75.29
5	Data Byte 2	7B ₁₆	
6	Data Byte 3	42 ₁₆	
7	Data Byte 4	96 ₁₆	
8	CRC Lo	17 ₁₆	CRC Checksum
9	CRC Hi	63 ₁₆	

In the example above the Input register requested contains a floating point number and needs to be accessed as a pair of registers (3001/3002). The resulting 4 bytes in the data response can then be decoded into a floating-point number (See Section 5.3 on page 20 and Appendix C on page 93 for further details on encoding and decoding floating point numbers).

6.5	05 (05₁₆): Force Single Coil
------------	--

This function permits the user to set the state of a single Discrete Output “Coil” register. (See Section 7.2 on page 39 for details of the individual registers). In the MFC010 implementation, these registers are used to initiate commands and functions. Setting the Output state initiates the function, attempting to clear the Output state will result in a data error. The format of the Master request telegram for this function should be as follows.

Request Character	Field	For Example	
1	Slave Address	01 ₁₆	Request to Slave ID 1
2	Function	05 ₁₆	“Force Single Coil”
3	Coil Address Hi	03 ₁₆	Coil Address = 1001
4	Coil Address Lo	E8 ₁₆	
5	Force Data Hi	FF ₁₆	Set Coil “Active”
6	Force Data Lo	00 ₁₆	
7	CRC Lo	0C ₁₆	CRC Checksum
8	CRC Hi	4A ₁₆	

The MFC010 will respond to such a request with a telegram formatted as follows.

Response Character	Field	For Example	
1	Slave Address	01 ₁₆	Response from Slave ID 1
2	Function	05 ₁₆	“Force Single Coil”
3	Coil Address Hi	03 ₁₆	Coil Address = 1001
4	Coil Address Lo	E8 ₁₆	
5	Force Data Hi	FF ₁₆	Set Coil “Active”
6	Force Data Lo	00 ₁₆	
7	CRC Lo	0C ₁₆	CRC Checksum
8	CRC Hi	4A ₁₆	

The MFC010 (slave) response telegram should be an exact duplicate of the master request telegram.

6.6	06 (06₁₆): Preset Single Register
------------	---

This function permits the user to set the value of a single Holding register. For this reason this command cannot be used to write to variables that occupy multiple consecutive registers such as floating point and long integer variables (See Section 7.5 on page 49 for details of the individual registers). The format of the Master request telegram for this function should be as follows.

Request Character	Field	For Example	
1	Slave Address	01 ₁₆	Request to Slave ID 1
2	Function	06 ₁₆	"Preset Single Register"
3	Register Address Hi	03 ₁₆	Register Address = 1020
4	Register Address Lo	FB ₁₆	
5	Preset Data Hi	00 ₁₆	Set Register 1020 = 35
6	Preset Data Lo	23 ₁₆	
7	CRC Lo	B9 ₁₆	CRC Checksum
8	CRC Hi	A6 ₁₆	

The MFC010 will respond to such a request with a telegram formatted as follows.

Response Character	Field	For Example	
1	Slave Address	01 ₁₆	Response from Slave ID 1
2	Function	06 ₁₆	"Preset Single Register"
3	Register Address Hi	03 ₁₆	Register Address = 1020
4	Register Address Lo	FB ₁₆	
5	Preset Data Hi	00 ₁₆	Set Register 1020 = 35
6	Preset Data Lo	23 ₁₆	
7	CRC Lo	B9 ₁₆	CRC Checksum
8	CRC Hi	A6 ₁₆	

The MFC010 (slave) response telegram should be an exact duplicate of the master request

6.7	07 (07₁₆): Read Exception Status
------------	--

When the Master device requests this command function, the MFC010 will respond with a single 8 bit data character summarizing the status of the instrument. The Master query telegram format is.

Request Character	Field	For Example
1	Slave Address	01 ₁₆ Request to Slave ID 1
2	Function	07 ₁₆ "Read Exception Status"
3	CRC Lo	41 ₁₆
4	CRC Hi	E2 ₁₆ CRC Checksum

The MFC010 will respond to such a request with a telegram formatted as follows.

Response Character	Field	For Example
1	Slave Address	01 ₁₆ Response from Slave ID 1
2	Function	07 ₁₆ "Read Exception Status"
3	Status	3D ₁₆ Data = 00111101 ₂
4	CRC Lo	E3 ₁₆
5	CRC Hi	E1 ₁₆ CRC Checksum

The Status character received in the response will be formatted as follows :

Bit 0 (LSB)	System State :	00 ₂ = Measuring, 01 ₂ = Standby,
Bit 1		10 ₂ = Stop, 11 ₂ = Start-up.
Bit 2	EEPROM Save Status :	0 = All Data Saved to EEPROM 1 = Data Write to EEPROM Pending
Bit 3	Process Control Status :	0 = Process Control Inactive (Control Condition Invalid) 1 = Process Control Active (Control Condition Valid)
Bit 4	Zero Calibration Status :	0 = Zero Calibration OK 1 = Zero Calibration Error
Bit 5	Density Calibration Status :	0 = Density Calibration OK 1 = Density Calibration Error
Bit 6	Process Warning Status :	0 = No Process Warning Flag(s) Detected 1 = Process Warning Flag(s) Detected
Bit 7 (MSB)	System Error Status :	0 = No System Error Flag(s) Detected 1 = System Error Condition Flag(s) Detected

6.8 08 (08₁₆): Diagnostics

This command function permits the user to perform one of several diagnostic operations, such as retrieving the error and event logs. For further details on this command function, refer to the Modbus specification.

6.9 11 (0B₁₆): Fetch Comm. Event Counter

This function allows the master device to determine if request telegrams are being properly processed. The Event count returned is a count of the number of request telegrams which have been received and processed without errors occurring. By fetching the Event count before and after a series of messages the master can determine whether the messages were handled normally. When the Master device requests this command function the MFC010 will respond with a two character (16 bit) status value and a two character event count. The Master request telegram should be formatted as follows.

Request Character	Field	For Example	
1	Slave Address	01 ₁₆	Request to Slave ID 1
2	Function	0B ₁₆	"Fetch Comm. Event Counter"
3	CRC Lo	41 ₁₆	CRC Checksum
4	CRC Hi	E7 ₁₆	

The MFC010 will respond to such a request with a telegram formatted as follows.

Response Character	Field	For Example	
1	Slave Address	01 ₁₆	Response from Slave ID 1
2	Function	0B ₁₆	"Fetch Comm. Event Counter"
3	Status Hi	FF ₁₆	Instrument Status
4	Status Lo	FF ₁₆	
5	Count Hi	1E ₁₆	Event Count = 7891
6	Count Lo	D3 ₁₆	
7	CRC Lo	EC ₁₆	CRC Checksum
8	CRC Hi	12 ₁₆	

The status value is either FFFF₁₆, in which case the slave is still processing a command, or 0000₁₆, in which case the slave is ready to receive the next command request.

6.10 16 (10₁₆): Preset Multiple Registers

This function permits the user to set the value of a number of consecutive Holding registers. This command function must be used to write to variables which occupy multiple consecutive registers such as floating point and long integer variables (See Section 7.5 on page 49 for details of the individual registers). Some of the Variables which occupy single (16 bit) registers cannot be set using this command, the Password registers (1001-1003) in particular. Command Function 06 (06₁₆) must be used to set these registers. The format of the Master request telegram for this function should be as follows.

Request Character	Field	For Example	
1	Slave Address	01 ₁₆	Request to Slave ID 1
2	Function	10 ₁₆	"Preset Multiple Registers"
3	Starting Address Hi	03 ₁₆	Starting Register Address = 1020
4	Starting Address Lo	FB ₁₆	
5	No. of Registers Hi	00 ₁₆	Number of Registers = 2
6	No. of Registers Lo	02 ₁₆	
7	Byte Count	04 ₁₆	No of Bytes = 4 (2 x 2)
8	Data Hi	00 ₁₆	Set Register 1020 = 17
9	Data Lo	11 ₁₆	
10	Data Hi	00 ₁₆	Set Register 1021 = 18
11	Data Lo	12 ₁₆	
12	CRC Lo	79 ₁₆	CRC Checksum
13	CRC Hi	A0 ₁₆	

The MFC010 will respond to such a request with a telegram formatted as follows.

Response Character	Field	For Example	
1	Slave Address	01 ₁₆	Response from Slave ID 1
2	Function	10 ₁₆	"Preset Multiple Registers"
3	Starting Address Hi	03 ₁₆	Starting Register Address = 1020
4	Starting Address Lo	FB ₁₆	
5	No. of Registers Hi	00 ₁₆	Number of Registers = 2
6	No. of Registers Lo	02 ₁₆	
7	CRC Lo	30 ₁₆	CRC Checksum
8	CRC Hi	7D ₁₆	

6.11	17 (11₁₆): Report Slave ID
-------------	--

The Report Slave ID command is useful to retrieve all of the identification information from the system with one simple short request. The master request telegram should be 4 bytes long and formatted as follows.

Request Character	Field	For Example
1	Slave Address	01 ₁₆ Request to Slave ID 1
2	Function	11 ₁₆ "Report Slave ID"
4	CRC Lo	C0 ₁₆ rowspan="2">CRC Checksum
5	CRC Hi	2C ₁₆

The MFC010 response telegram will be 57 characters long (including the two CRC checksum bytes appended to the telegram) and is structured as follows.

Response Character	Field	For Example
1	Slave Address	01 ₁₆ Response from Slave ID 1
2	Function	11 ₁₆ "Report Slave ID"
3	Byte Count	34 ₁₆ "No of bytes in Reply " = 52
4	Device ID	00 ₁₆ 00 = MFC010
5	Run Indicator	FF ₁₆ 0 = Off, FF ₁₆ = On
6	Sensor Type (See Holding Register No. 1012)	
7	Sensor Size (See Holding Register No. 1013)	
8	Sensor Material (See Holding Register No. 1014)	
9 – 20	Software Version - 12 Character ASCII String	
21 – 34	Software Number - 14 Character ASCII String	
35 – 46	Software Compilation Date - 12 Character ASCII String	
47 – 49	MFC010 Serial Number – 24 bit Integer (Most Significant Byte First)	
50 – 52	Sensor Serial Number – 24 bit Integer (Most Significant Byte First)	
53 - 55	System Serial Number – 24 bit Integer (Most Significant Byte First)	
56	CRC Lo	CRC Checksum
57	CRC Hi	

7. MFC010 Modbus Data Model

7.1 MFC010 Register Structure

The register structure for the MFC010 begins with register 1001 in all register types (Discrete Output, Discrete Input, Input Register and Holding Register). The different variable types (integer, float, double etc) have been arranged into groups of the same data type spread over the entire permitted register address range.

It is not permissible, within this implementation of the MFC010 Modbus interface, to retrieve registers containing different data types within the same request telegram. Attempts to achieve this will be responded to with an "Illegal Data Address" exception error (See Section 5.6 on page 22).

Large gaps have been left between these groups of data types in order to permit expansion of the MFC010 interface and compatibility with future high performance converters.

Data variables which require more than one register (e.g. a 4 byte "Float" requires two 2 byte registers to transmit it) will occupy the number of consecutive registers needed to hold the variable. For example if a floating point variable is contained in Register 3001, this will also fill register 3002. For this reason any attempt to read 3002 directly will be responded to with an "Illegal Data Address" exception error (See Section 5.6 on page 22). This is the same for both Long Integers (which also require 2 consecutive 2 byte registers to hold 4 bytes) and Double Precision Floating Point Numbers (which require 4 consecutive 2 byte registers to hold the 8 byte format of the Double Float).

In addition, when accessing these multi-register variables, the user must request the correct multiple of registers. i.e. when accessing Floating Point and Long integer variables, the number of registers requested must be a multiple of 2, and when requesting Double Precision floating point variables the number of registers requested must be a multiple of 4. Requesting variables with the incorrect multiple of registers will again result in an "Illegal Data Address" exception error (See Section 5.6 on page 22). For example if a request was made to a group of floating point variable register locations but only 3 registers were requested, then the exception error would be returned.

Some of the following registers are protected by the "Service" password to prevent accidental or unauthorised changes to key configuration values, specifically the sensor calibration settings, these registers are indicated by the following symbol.



For details on the operation and de-activation of the Service Password see section 8.5. Similarly, some registers are protected by a Custody Transfer Password for use when the MFC010 is used in Custody transfer applications, see section 8.9 on page 78. These registers are indicated by the **CT** symbol.

Holding registers marked **RO** are "Read Only".

The following is a summary of the MFC010 register structure, the details of which are explained in the following sections.

Register	Description	
Discrete Output (Binary) States (and Commands)		
0XXXX Registers, Accessed Using Commands 01 and 05		
1001	Save Changes to EEPROM	
1002	Begin Zero Calibration	
1003	Reset Totalisers	CT
1004	Reset Additional Totaliser	
1005	Request STANDBY Mode	CT
1006	Request STOP Mode	CT
1007	Request MEASURE Mode	
1008	Reset Errors	
1009	Reset Warnings	
1010	Discard Previous Write Operations	
1011	Initiate Single Point Density Calibration	CT
1012	Initiate Two Point Density Calibration	CT
1013	Continue Two Point Density Calibration	CT
1014	Reset to Factory Density Calibration	CT

Discrete Input (Binary) States

1XXXX Registers, Accessed Using Command 02

1001	Supervisor Lock Password State
1002	Service Lock Password State
1003	Custody Transfer Lock Password State
1004	Parameters Changed, Awaiting "Save Changes to EEPROM"
1005	System Error Flag
1006	Process Warning Flag
1007	Density Calibration Status
1008	Mass Flow Zero Calibration Status
1009	Process Control Status

Input Registers

3XXXX Registers, Accessed Using Command 04

Single Registers (16 bit Integer Values)

1001	Sensor A Level
1002	Sensor B Level
1003	Drive Level
1004	System State
1005	DCF1
1006	DCF5

Floating Point Values (Accessed in pairs of registers)

3001	Mass Flow
3003	Density
3005	Temperature
3007	Volume Flow
3009	Concentration 1 Flow

Register	Description
3011	Concentration 2 Flow
3013	Concentration 1
3015	Concentration 2
3017	Velocity
3019	Mass Total
3021	Volume Total
3023	Concentration 1 Total
3025	Concentration 2 Total
3027	Additional Total
3029	Tube Frequency
3031	Measuring Tube Strain
3033	Inner Cylinder Strain
3035	DCF2
3037	DCF3
3039	DCF4
3041	DCF6
3043	DCF7
3045	DCF8
3047	Zero Calibration Percent
3049	Maximum Instrument Temperature
3051	Minimum Instrument Temperature
3053	2 Phase Signal

Double Precision Floating Point Values (Accessed in groups of four registers)

5001	Mass Total
5005	Volume Total
5009	Concentration 1 Total
5013	Concentration 2 Total
5017	Additional Total

Long Integer Values (Accessed in pairs of registers)

7001	System Error Flags
7003	Process Warning Flags
7005	Stored System Error Flags
7007	Stored Process Warning Flags

Holding Registers

4XXXX Registers, Accessed Using Commands 03, 06 and 16 (* Command 03 and 06 Only)







Single Registers (16 bit Integer Values)

1001	Supervisor Lock Password*
1002	Service Lock Password*
1003	Custody Transfer Lock Password*
1004	Modbus Communications Format
1005	Modbus Communications Baud rate
1006	Modbus Communications Address
1007	Flow Direction



Register	Description		
1008	Flow Mode	rw	
1009	Internal Process Control Function	rw	
1010	Internal Process Control Condition	rw	
1011	Concentration 1 Function		
1012	Sensor Type	rw	✘
1013	Sensor Size	rw	✘
1014	Sensor Material	rw	✘
1015	Tube Amplitude		✘
1016	Concentration Type		
1017	Concentration 1 Product		
1018	Concentration Coefficient 5		
1019	Density Mode	rw	
1020	Mass Flow Units		
1021	Density Units		
1022	Mass Total Units	rw	
1023	Volume Total Units	rw	
1024	Volume Flow Units		
1025	Temperature Units		
1026	Velocity Units		
1027	Additional Totaliser Source		
1028	Density Calibration Product Type		
1029	Concentration 2 Function		
1030	Concentration 2 Product		
1031	CF25	rw	✘
1032	Year of Manufacture		✘
Floating Point Values (Accessed in pairs of registers)			
3001	CF1	rw	✘
3003	CF2	rw	✘
3005	CF3	rw	✘
3007	CF4	rw	✘
3009	CF5	rw	✘
3011	CF6	rw	✘
3013	CF7	rw	✘
3015	CF8	rw	✘
3017	CF9		RO
3019	CF10		RO
3021	CF11	rw	✘
3023	CF12	rw	✘
3025	CF13	rw	✘
3027	CF14	rw	✘
3029	CF15	rw	✘
3031	CF16	rw	✘
3033	CF17	rw	✘
3035	CF18	rw	✘
3037	CF19	rw	✘

Register	Description		
3039	CF20	CT	✘
3041	Meter Correction	CT	
3043	Pipe Diameter		
3045	Measurement Time Constant		
3047	Low Flow Threshold	CT	
3049	User Flow Offset	CT	
3051	Internal Process Control Maximum Limit		
3053	Internal Process Control Minimum Limit		
3055	Referred Density Reference Temperature		
3057	Fixed Density Value		
3059	Referred Density Slope		
3061	Concentration Coefficient 2		
3063	Concentration Coefficient 3		
3065	Concentration Coefficient 4		
3067	Concentration Coefficient 6		
3069	Concentration Coefficient 7		
3071	Concentration Coefficient 8		
3073	Concentration Coefficient 9		
3075	Concentration Coefficient 10		
3077	Concentration Coefficient 11		
3079	Concentration Coefficient 12		
3081	Concentration 1 Offset		
3083	User Defined Mass Total Units Scaling		
3085	User Defined Volume Total Units Scaling		
3087	User Defined Mass Flow Units Scaling		
3089	User Defined Volume Flow Units Scaling		
3091	User Defined Density Units Scaling		
3093	Calibration Density		
3095	Temperature During Last Zero Calibration	RO	
3097	Maximum Sensor Temperature Specification		✘
3099	Minimum Sensor Temperature Specification		✘
3101	Pressure Suppression Duration	CT	
3103	Pressure Suppression Cut-off	CT	
3105	Density Averaging	CT	
3107	Concentration 2 Offset		
3109	CF21	CT	✘
3111	CF22	CT	✘
3113	CF23	CT	✘
3115	CF24	CT	✘
3117	CF26	CT	✘
3119	CF27	CT	✘
3121	2 Phase Warning Level		

Register	Description		
<i>Long Integer Values (Accessed in pairs of registers)</i>			
7001	MFC010 Serial Number		
7003	System Serial Number		
7005	Meter Serial Number		
7007	Enable Concentration Calculation		

7.2 Discrete Status Output “Coil” Registers

The discrete Status Output, or “Coil”, registers are used by the MFC010 to initiate special functions and operations. When read, the values are meaningless and in most cases are just returned by the MFC010 as 0. Some of the operations require a more detailed explanation; this can be found later in this document in Section 8.

Use Modbus command number 01 to read the state of these registers (see section 6.1 on page 23) and Modbus command number 05 to activate the output register/command (see section 6.5 on page 27).

Register No.	Description
1001	Save Changes to EEPROM - Store the configuration changes made into the non-volatile memory. See Section 8.6 on page 77 for a more detailed explanation of saving and restoring configuration settings.
1002	Begin Zero Flow Calibration - Initiate a calibration of the zero flow offset. See Section 8.1 on page 71 for further details. Reads value “1” when zero calibration in process and “0” when complete.
1003 CT	Reset Totalisers - Resets all Totaliser values.
1004	Reset Additional Totaliser - Reset the Additional Totaliser.
1005 CT	Request STANDBY Mode - Place the instrument into “Standby” mode, where the meter oscillation continues but the Mass flow reading is set to Zero. Valid Temperature and Strain measurements continue to be made during the “Standby” mode. Reads “1” when set
1006 CT	Request STOP Mode - Place the instrument into “Stop” mode, where the meter oscillation stops and all mass flow measurement stops. Valid Temperature and Strain measurements continue to be made during the “Stop” mode. Reads “1” when set
1007	Request MEASURE mode - Place the instrument into “Measure” mode, all measurement and totalising restarts. Reads “1” when set
NOTE: For above 3 registers, only 1 of the coils will be set at any one time. Writing to any 1 of the 3 coils will clear the other 2.	
1008	Reset Errors - Clears the Stored System Error Flags (See Input Register No 7005). Will not reset Custody sensitive errors when Custody Transfer lock is active, see section 8.9 on page 78 for details.
1009	Reset Warnings - Clears the Stored Process Warning Flags (See Input Register No 7007). Will not reset Custody sensitive warnings when Custody Transfer lock is active, see section 8.9 on page 78 for details.

Register No.	Description
1010	<p>Discard Previous Write Operations</p> <p>– Discard all of the configuration changes made since the last write to EEPROM operation (see Coil Register 1001 above). See Section 8.6 on page 77 for a more detailed explanation of saving and restoring configuration settings.</p>
1011	<p>Initiate Single Point Density Calibration</p> <p>CT – Initiate a single point calibration of the density measurement system according to the settings of the Calibration Density Type (See Holding Register 1028) and the Calibration Density Value (See Holding Register No 3093). See Section 8.2 on page 72 for further details.</p>
1012	<p>Initiate Two Point Density Calibration</p> <p>CT – Perform a calibration on the first of a two point density calibration according to the settings of the Calibration Density Type (See Holding Register 1028) and the Calibration Density Value (See Holding Register No 3093). See Section 8.2 on page 72 for further details.</p>
1013	<p>Continue Two Point Density Calibration</p> <p>CT – Perform a calibration on the second of a two point density calibration according to the settings of the Calibration Density Type (See Holding Register 1028) and the Calibration Density Value (See Holding Register No 3093). This will only be permitted if the first point has been calibrated previously (See Output Register No. 1012). See Section 8.2 on page 72 for further details.</p>
1014	<p>Reset to Factory Density Calibration</p> <p>CT – Resets the instrument Density calibration to the settings determined at the point of manufacture during initial instrument calibration. See Section 8.2 on page 72 for further details.</p>
<p>NOTE: For registers 1010 to 1014, the value of the coil reads “1” when the process is in progress, and “0” when complete.</p>	

7.3 Discrete Input (Binary) Status Registers

The Discrete Input Status registers are used to indicate to the control system the current state of the meter. From these values the user can access more detailed information in the other register groups. Many of these states can also be accessed using the “Read Exception Status” command (Command No. 7).

Register No.	Description
1001	<p>Supervisor Lock Password State</p> <p>- The current state of the Supervisor Password protection. For details on activation, de-activation and operation of the Supervisor password refer to Section 8.5 on page 76 for further details.</p> <p>Range : 0 = Password Protection is Inactive 1 = Password Protection is Active</p>
1002	<p>Service Lock Password State</p> <p>- The current state of the Service Password protection. For details on activation, de-activation and operation of the Service password refer to Section 8.5 on page 76 for further details.</p> <p>Range : 0 = Password Protection is Inactive 1 = Password Protection is Active</p>
1003	<p>Custody Transfer Lock Password State</p> <p>- The current state of the Custody Transfer Lock Password protection. For details on activation, de-activation and operation of the Custody Transfer password refer to Section 8.9 on page 78 for further information.</p> <p>Range : 0 = Password Protection is Inactive 1 = Password Protection is Active</p>
1004	<p>Parameter Changed – Awaiting “Save Changes to EEPROM”</p> <p>– This state indicates when configuration changes have been made but not yet saved to the non-Volatile memory (EEPROM). See Section 8.6 on page 77 for a more detailed explanation of saving and restoring configuration settings.</p> <p>Range : 0 = No new data to save 1 = Data has been written but not stored in EEPROM</p>
1005	<p>System Error Flag</p> <p>– This state indicates when the system has detected one or more error conditions that may affect the operation of the meter. The individual System Error flags are accessed from Input Register No 7001. (See Section 9 for more details on Errors and Warnings)</p> <p>Range : 0 = No system error flags detected 1 = One or more system error conditions are present</p>
1006	<p>Process Warning Flag</p> <p>– This state indicates when the system has detected one or more process conditions that may affect the operation of the meter. The individual Process warning flags are accessed from Input Register No 7005. (See section 9 for more details on Errors and Warnings).</p> <p>Range : 0 = No process warning flags detected 1 = One or more process warning conditions are present</p>

Register No.	Description
1007	<p>Density Calibration Status</p> <p>– This state indicates when the system has detected an error during the density calibration. This will only be active for the latest attempt at a density calibration. If this bit indicates that the latest density calibration failed, then the previous density calibration will still be being used. See Section 8.2 on page 72 for further details on Density calibration.</p> <p>Range : 0 = The last Density Calibration was successful 1 = An error was detected during the last Density Calibration</p>
1008	<p>Mass Flow Zero Calibration Status</p> <p>– This state indicates when the system has detected an error during the mass flow zero calibration. This will only be active for the latest attempt at a calibration. If this bit indicates that the latest zero calibration failed, then the previous zero calibration will still be being used. See Section 8.1 on page 71 for further details on Mass Flow Zero Calibration.</p> <p>Range : 0 = The last Mass Flow Zero Calibration was successful 1 = An error was detected during the last Zero Calibration.</p>
1009	<p>Process Control Status</p> <p>– This state indicates when the Internal process control mechanism is active. See section 8.8 on page 78 for more details on the Internal Process control system</p> <p>Range : 0 = Internal Process Control In-active 1 = Internal Process Control Active</p>

7.4 Input Registers

The input registers contain the measurement values and diagnostic data that the MFC010 produces. All of these registers are read only.

Register No.	Description
1001	<p>Sensor A Level</p> <p>- The measured input level for Sensor A as a percentage of the maximum possible input.</p> <p>Format : Unsigned Integer</p> <p>Range : 0% to 100%</p>
1002	<p>Sensor B Level</p> <p>- The measured input level for Sensor B as a percentage of the maximum possible input.</p> <p>Format : Unsigned Integer</p> <p>Range : 0% to 100%</p>
1003	<p>Drive Level</p> <p>- The output power to the Drive coil as a percentage of the maximum possible output.</p> <p>Format : Unsigned Integer</p> <p>Range : 0% to 100%</p>
1004	<p>System State</p> <p>- The current operating condition of the sensor system. This can be changed using the "Request System State" commands (see Coil Register No's 1005 – 1007).</p> <p>Format : Unsigned Integer</p> <p>Range : 1 = Stop 2 = Start-up 3 = Measuring 4 = Not Used 5 = Standby 6 = Zero Calibration</p>
1005	<p>Density Calibration Coefficient DCF1</p> <p>- The fluid type defined for the calibration of Density Point #1</p> <p>Format : Unsigned Integer</p> <p>Range : 0 = Empty 1 = Pure Water (998.2 kg/m³ @ 20°C) 2 = Town Water (999.7 kg/m³ @ 20°C) 3 = Other</p>
1006	<p>Density Calibration Coefficient DCF2</p> <p>- The fluid type defined for the calibration of Density Point #2</p> <p>Format : Unsigned Integer</p> <p>Range : 0 = Empty 1 = Pure Water (998.2 kg/m³ @ 20°C) 2 = Town Water (997.7 kg/m³ @ 20°C) 3 = Other</p>

Register No.	Description
3001 / 3002	<p>Mass Flow</p> <p>- The measured mass flow rate after filtering. Proportional to the Phase shift detected between the sensors. The value transmitted is scaled according to the setting of the "Mass Flow Units" (see Holding Register No.1020)</p> <p>Format : Floating Point</p> <p>Range : Dependant on the sensor type and selected units</p>
3003 / 3004	<p>Density</p> <p>- The measured density after filtering. Inversely proportional to the oscillation frequency of the measuring tube. The value transmitted is scaled according to the setting of the "Density Units" (see Holding Register No.1021). This value may be fixed or referred according to the setting of the "Density Mode" (see Holding Register No.1019)</p> <p>Format : Floating Point</p> <p>Range : 0.05 kg/m³ to 3000 kg/m³</p>
3005 / 3006	<p>Temperature</p> <p>- The measured temperature of the measuring tube. The value is scaled according to the setting of the "Temperature Units" (see Holding Register No.1025)</p> <p>Format : Floating Point</p> <p>Range : -250 °C to + 500 °C</p>
3007 / 3008	<p>Volume Flow</p> <p>- The volume flow rate, determined from the Mass flow and Density measurements. The value transmitted is scaled according to the setting of the "Volume Flow Units" (see Holding Register No.1024)</p> <p>Format : Floating Point</p> <p>Range : Dependant on the sensor type and selected units</p>
3009 / 3010	<p>Concentration 1 Flow</p> <p>- The flowrate of the defined concentration component. The value transmitted is scaled according to the setting of the "Mass Flow Units" (see Holding Register No.1020) or "Volume Flow Units" (see Holding Register No. 1024)</p> <p>Format : Floating Point</p> <p>Range : Dependant on the sensor type and selected units</p>
3011 / 3012	<p>Concentration 2 Flow</p> <p>- The flowrate of the defined concentration component. The value transmitted is scaled according to the setting of the "Mass Flow Units" (see Holding Register No.1020) or "Volume Flow Units" (see Holding Register No. 1024)</p> <p>Format : Floating Point</p> <p>Range : Dependant on the sensor type and selected units</p>
3013 / 3014	<p>Concentration 1</p> <p>- The proportion of the selected product in the solution. The value transmitted is scaled according to the setting of the "Concentration 1 Function" (see Holding Register No.1011). When using "% Mass" or "% Volume" the selected product may be either the solute or the solvent according to the setting of "Concentration 1 Product" (see Holding Register No.1017).</p> <p>Format : Floating Point</p> <p>Range : Dependant on the selected units</p>

Register No.	Description
3015 / 3016	<p>Concentration 2</p> <p>- The proportion of the selected product in the solution. The value transmitted is scaled according to the setting of the "Concentration 2 Function" (see Holding Register No.1029). When using "% Mass" or "% Volume" the selected product may be either the solute or the solvent according to the setting of "Concentration 2 Product" (see Holding Register No.1030).</p> <p>Format : Floating Point Range : 0.0% to 100.0%</p>
3017 / 3018	<p>Velocity</p> <p>- The velocity at which the medium is passing through the sensor, determined by the Volume Flow and the Pipe Diameter (see Holding Register No.3043). The value transmitted is scaled according to the setting of the "Velocity Units" (see Holding Register No.1026)</p> <p>Format : Floating Point Range : Dependant on the sensor type and selected units</p>
3019 / 3020	<p>Mass Total</p> <p>- The accumulation of mass flow over time. This totaliser can be reset using the "Reset Totalisers" command (see Coil Register No.1003). The value transmitted is scaled according to the setting of the "Mass Total Units" (see Holding Register No.1022). NB Input register 5001 contains a reading with higher resolution, double floating point format, for this variable.</p> <p>Format : Floating Point Range : -1×10^{12} to $+1 \times 10^{12}$ kg</p>
3021 / 3022	<p>Volume Total</p> <p>- The accumulation of volume flow over time. This totaliser can be reset using the "Reset Totalisers" command (see Coil Register No.1003). The value transmitted is scaled according to the setting of the "Volume Total Units" (see Holding Register No.1023)). NB Input register 5005 contains a reading with higher resolution, double floating point format, for this variable.</p> <p>Format : Floating Point Range : -1×10^9 to $+1 \times 10^9$ m³</p>
3023/ 3024	<p>Concentration 1 Total</p> <p>- The accumulation of mass of the concentration product over time. This totaliser can be reset using the "Reset Totalisers" command (see Coil Register No.1003). The value transmitted is scaled according to the setting of the "Mass Total Units" (see Holding Register No.1022) or "Volume Flow Units (see Holding Register 1023). NB Input register 5009 contains a reading with higher resolution, double floating point format, for this variable.</p> <p>Format : Floating Point Range : -1×10^{12} to $+1 \times 10^{12}$ kg or -1×10^9 to $+1 \times 10^9$ m³</p>
3025 / 3026	<p>Concentration 2 Total</p> <p>- The accumulation of mass of the concentration product over time. This totaliser can be reset using the "Reset Totalisers" command (see Coil Register No.1003). The value transmitted is scaled according to the setting of the "Mass Total Units" (see Holding Register No.1022) or "Volume Flow Units (see Holding Register 1023). NB Input register 5013 contains a reading with higher resolution, double floating point format, for this variable.</p> <p>Format : Floating Point Range : -1×10^{12} to $+1 \times 10^{12}$ kg or -1×10^9 to $+1 \times 10^9$ m³</p>

Register No.	Description
3027 / 3028	<p>Additional Total</p> <p>- The additional totaliser can be selected to be a sub-totaliser of one of the other four main totalisers, allowing batch operation and reset without affecting the main totaliser values. Use Holding register No 1027 to select which of the four main totalisers is the source totaliser. This totaliser can be reset using the "Reset Totalisers" command (see Coil Register No.1003) or the "Reset Additional Totaliser" command (see Coil Register No 1004). The value transmitted is scaled according to the setting of the units associated with the source totaliser. NB Input register 5017 contains a reading with higher resolution, double floating point format, for this variable.</p> <p>Format : Floating Point</p> <p>Range : -1×10^{12} to $+1 \times 10^{12}$ kg or -1×10^9 to $+1 \times 10^9$ m³</p>
3029 / 3030	<p>Tube Frequency</p> <p>- The measured oscillation frequency of the measuring tube</p> <p>Format : Floating Point</p> <p>Range : 50Hz to 2000 Hz</p>
3031 / 3032	<p>Measuring Tube Strain</p> <p>- The measured resistance of the measuring tube strain gauge.</p> <p>Format : Floating Point</p> <p>Range : 0 Ω to 1000 Ω</p>
3033 / 3034	<p>Inner Cylinder Strain</p> <p>- The measured resistance of the inner cylinder strain gauge.</p> <p>Format : Floating Point</p> <p>Range : 0 Ω to 1000 Ω</p>
3035 / 3036	<p>Density Calibration Coefficient DCF2</p> <p>- The density value for the density calibration point #1</p> <p>Format : Floating Point</p> <p>Range : -1000 kg/m³ to 3000 kg/m³</p>
3037 / 3038	<p>Density Calibration Coefficient DCF3</p> <p>- The Density Flow Compensation value calculated for the density calibration point #1</p> <p>Format : Floating Point</p> <p>Range : 0.01 to 100</p>
3039 / 3040	<p>Density Calibration Coefficient DCF4</p> <p>- The Temperature Correction value calculated for the density calibration point #1</p> <p>Format : Floating Point</p> <p>Range : 0.01 to 10 000 000</p>
3041 / 3042	<p>Density Calibration Coefficient DCF6</p> <p>- The density value for the density calibration point #2</p> <p>Format : Floating Point</p> <p>Range : -1000 kg/m³ to 3000 kg/m³</p>
3043 / 3044	<p>Density Calibration Coefficient DCF7</p> <p>- The Density Flow Compensation value calculated for the density calibration point #2</p> <p>Format : Floating Point</p> <p>Range : 0.01 to 100</p>
3045 / 3046	<p>Density Calibration Coefficient DCF8</p> <p>- The Temperature Correction value calculated for the density calibration point #2</p> <p>Format : Floating Point</p> <p>Range : 0.01 to 10 000 000</p>

Register No.	Description
3047 / 3048	<p>Zero Calibration Percent</p> <p>- The Zero Calibration value represented as a percentage of nominal flow (determined by the sensor type)</p> <p>Format : Floating Point</p> <p>Range : -10% to +10%</p>
3049 / 3050	<p>Maximum Recorded Instrument Temperature</p> <p>- The maximum process temperature that the sensor has measured. The value is scaled according to the setting of the "Temperature Units" (see Holding Register No.1025)</p> <p>Format : Floating Point</p> <p>Range : +20°C to + 500 °C</p>
3051 / 3052	<p>Minimum Recorded Instrument Temperature</p> <p>- The minimum process temperature that the sensor has measured. The value is scaled according to the setting of the "Temperature Units" (see Holding Register No.1025)</p> <p>Format : Floating Point</p> <p>Range : -250 °C to + 20°C</p>
3053 / 3054	<p>2 Phase Signal</p> <p>- Indication of the 2 phase signal level of the unit. This value is application & process dependent and it can be used to determine the set point for the 2-phase flow alarm function (see Holding Register No.3021)</p> <p>Range : 0.0 to 1000.0</p>
5001 - 5004	<p>Mass Total</p> <p>- The accumulation of mass flow over time. This totaliser can be reset using the "Reset Totalisers" command (see Coil Register No.1003). The value transmitted is scaled according to the setting of the "Mass Total Units" (see Holding Register No.1022)</p> <p>Format : Double Precision Floating Point</p> <p>Range : - 1 x 10¹² to +1 x 10¹² kg</p>
5005 - 5008	<p>Volume Total</p> <p>- The accumulation of volume flow over time. This totaliser can be reset using the "Reset Totalisers" command (see Coil Register No.1003). The value transmitted is scaled according to the setting of the "Volume Total Units" (see Holding Register No.1023)</p> <p>Format : Double Precision Floating Point</p> <p>Range : - 1 x 10⁹ to +1 x 10⁹ m³</p>
5009 - 5012	<p>Concentration 1 Total</p> <p>- The accumulation of mass of the concentration product over time. This totaliser can be reset using the "Reset Totalisers" command (see Coil Register No.1003). The value transmitted is scaled according to the setting of the "Mass Total Units" (see Holding Register No.1022) or "Volume Flow Units" (see Holding Register 1023). NB Input register 5009 contains a reading with higher resolution, double floating point format, for this variable.</p> <p>Format : Double Precision Floating Point</p> <p>Range : -1 x 10¹² to +1 x 10¹² kg or -1 x 10⁹ to +1 x 10⁹ m³</p>

Register No.	Description
5013 - 5016	<p>Concentration 2 Total</p> <p>- The accumulation of mass of the concentration product over time. This totaliser can be reset using the "Reset Totalisers" command (see Coil Register No.1003). The value transmitted is scaled according to the setting of the "Mass Total Units" (see Holding Register No.1022) or "Volume Flow Units (see Holding Register 1023). NB Input register 5009 contains a reading with higher resolution, double floating point format, for this variable.</p> <p>Format : Double Precision Floating Point Range : -1×10^{12} to $+1 \times 10^{12}$ kg or -1×10^9 to $+1 \times 10^9$ m³</p>
5017 – 5020	<p>Additional Total</p> <p>- The additional totaliser can be selected to be a sub-totaliser of one of the other four main totalisers, allowing batch operation and reset without affecting the main totaliser values. Use Holding register No 1027 to select which of the four main totalisers is the source totaliser. This totaliser can be reset using the "Reset Totalisers" command (see Coil Register No.1003) or the "Reset Additional Totaliser" command (see Coil Register No 1004). The value transmitted is scaled according to the setting of the units associated with the source totaliser.</p> <p>Format : Double Precision Floating Point Range : -1×10^{12} to $+1 \times 10^{12}$ kg or -1×10^9 to $+1 \times 10^9$ m³</p>
7001/ 7002	<p>Active System Errors</p> <p>- A group of 32 flags that indicate when system errors or malfunctions are present. See section 9 for detailed explanations of the meaning of each flag. When the cause of the error is removed the flag will be cleared. A record of error events is kept in the Stored System Errors (see Input Register No 7005 below) .</p> <p>Format : Unsigned Long</p>
7003 / 7004	<p>Active Process Warnings</p> <p>- A group of 32 flags that indicate when adverse process conditions are affecting the operation or accuracy of the meter. See section 9 for detailed explanations of the meaning of each flag. When the cause of the warning condition disappears the flag will be cleared. A record of process warning events is kept in the Stored Process Warnings (see Input Register No 7007 below).</p> <p>Format : Unsigned Long</p>
7005 / 7006	<p>Stored System Errors</p> <p>- This value is a record of flags set in the System Errors register (See Input Register 7001 above). Use the "Reset Errors" command to clear the flags in this register. (See Output Status Coil Register 1008) Refer to section 9 for more details.</p> <p>Format : Unsigned Long</p>
7007 / 7008	<p>Stored Process Warnings</p> <p>- This value is a record of flags set in the Process Warnings register (See Input Register 7003 above). Use the "Reset Warnings" command to clear the flags in this register. (See Output Status Coil Register 1009) Refer to section 9 for more details.</p> <p>Format : Unsigned Long</p>

7.5 Holding Registers

The Holding Registers contain the configuration information for the MFC010. This configuration can be read, written to and stored in non-volatile memory. Each variable listed below has a valid range which can be written, and a set default value for when the "Reset Defaults" command (Output status Coil No. 1009) is activated.

With the exception of the output units scaling registers, changes to the registers listed below must be confirmed by using the "Save Changes to EEPROM" Output State register (see section 7.2 on page 39) before they are applied to the active measurement system (see section 8.6 on page 77 for further information on saving and restoring the configuration settings).

Register No.	Description
1001	<p>Supervisor Lock Password</p> <p>- See section 8.5 for details. This register CANNOT be written using command 16. An "Illegal Function" error response will be returned if it is attempted.</p> <p>Format : Unsigned Integer</p> <p>Range : 0 to 65535</p> <p>Default Value : 0</p>
1002	<p>Service Lock Password</p> <p>- See section 8.5 for details. This register CANNOT be written using command 16. An "Illegal Function" error response will be returned if it is attempted.</p> <p>Format : Unsigned Integer</p> <p>Range : 0 to 65535</p> <p>Default Value : NA</p>
1003	<p>Custody Transfer Lock Password</p> <p>- See section 8.9 for details. This register CANNOT be written using command 16. An "Illegal Function" error response will be returned if it is attempted.</p> <p>Format : Unsigned Integer</p> <p>Range : 0 to 65535</p> <p>Default Value : 0</p>
1004	<p>Modbus Transmission Format</p> <p>- The value held in this register determines the character transmission format of the Modbus telegrams (see section 5.1, on page 19 for details).</p> <p>Format : Unsigned Integer</p> <p>Range : 1 = Even Parity , 8 Data Bits, 1 Stop Bit 2 = Even Parity , 8 Data Bits, 2 Stop Bits 3 = Odd Parity , 8 Data Bits, 1 Stop Bit 4 = Odd Parity , 8 Data Bits, 2 Stop Bits 5 = No Parity , 8 Data Bits, 1 Stop Bit 6 = No Parity , 8 Data Bits, 2 Stop Bits</p> <p>Default Value : 1</p>

Register No.	Description
1005	<p>Modbus Baud Rate</p> <p>- The value held in this register determines the transmission rate of the Modbus interface.</p> <p>Format : Unsigned Integer</p> <p>Range : 1 = 1200 baud 2 = 2400 baud 3 = 4800 baud 4 = 9600 baud 5 = 19200 baud 6 = 38400 baud 7 = 57600 baud</p> <p>Default Value : 5</p>
1006	<p>Modbus Address</p> <p>- This is the ID address that is required at the start of a telegram to indicate that the received message is intended for this meter. (see section 5.2 on page 20).</p> <p>Format : Unsigned Integer</p> <p>Range : 1 to 247</p> <p>Default Value : 1</p>
1007	<p>CT</p> <p>Flow Direction</p> <p>- The setting of this register determines which flow direction is indicated as positive in terms of the Mass Flow and other directionally related measurements. "Positive" flow correlates with the flow direction label fixed to the front of the MFC010 electronics. "Negative" flow inverts the direction indicated by the mass flow readings to be opposite to that indicated by the flow direction label.</p> <p>Format : Unsigned Integer</p> <p>Range : 1 = Positive 2 = Negative</p> <p>Default Value : 1</p>
1008	<p>CT</p> <p>Flow Mode</p> <p>- The setting of this register may restrict the measurement to one direction, fixing the measurement value to 0 when the medium is flowing in the opposite direction.</p> <p>Format : Unsigned Integer</p> <p>Range : 1 = Positive Flow Only 2 = Negative Flow Only 3 = Positive and Negative Flow</p> <p>Default Value : 3</p>
1009	<p>CT</p> <p>Process Control Function</p> <p>- The value stored in this register determines the action taken by the Internal Process Control system when the control condition is active. See section 8.8 on page 78 for further details.</p> <p>Format : Unsigned Integer</p> <p>Range : 1 = Off 2 = Force Flow reading to 0 3 = Force Flow reading to zero and reset totalisers</p> <p>Default Value : 1</p>

Register No.	Description
1010	<p>CT Process Control Condition</p> <p>- The value stored in this register determines the source measurement that is used to activate the Internal Process Control System. See section 8.8 on page 78 for further details.</p> <p>Format : Unsigned Integer</p> <p>Range : 0 = Density 1 = Temperature</p> <p>Default Value : 1</p>
1011	<p>Concentration 1 Function</p> <p>- Determines the type of measurement calculation that the meter performs for Concentration 1. Can only be activated by means of the Concentration Password register No.7007. See section 8.4 on page 76 for details.</p> <p>Format : Unsigned Integer</p> <p>Range : 0 = De-activated (Option NOT Installed) 1 = Off 2 = °Brix 3 = % Mass (General Concentration) 4 = °Baumé 144.3 5 = °Baumé 145.0 6 = % NaOH 7 = °Plato 8 = % Volume (General Concentration) 9 = °API</p> <p>Default Value : 0</p>
1012	<p>X CT Sensor Type</p> <p>- The setting of the Sensor type determines the available sizes, materials and operating parameters of the sensor to which the MFC10 is attached. Changing this value will default the Sensor Size (Register No. 1013) and depending on option chosen the Material (Register No. 1014). <u>WARNING</u> : Changing this value will reset the calibration coefficients.</p> <p>Format : Unsigned Integer</p> <p>Range : 0 = OPTIMASS 7000 1 = OPTIMASS 3000 2 = OPTIGAS 5000 3 = OPTIMASS 8000 4 = OPTIMASS 9000 5 = OPTIMASS 1000</p> <p>Default Value : 0</p>

Register No.	Description
1015	<p>✂ Tube Amplitude</p> <p>- The sensor input amplitude to which the measuring tube oscillation control system must aim to achieve. The optimum setting for this value depends upon the sensor type and size.</p> <p>Format : Unsigned Integer</p> <p>Range : 1% to 98%</p> <p>Default Value: Dependent on Sensor Type and Size.</p>
1016	<p>Concentration Type</p> <p>- The extrapolation method used by the General concentration measurement calculation sub-system. (See Section 8.4 on page 76 for more details)</p> <p>Format : Unsigned Integer</p> <p>Range : 0 = Linear 1 = Non-Linear</p> <p>Default Value : 0</p>
1017	<p>Concentration 1 Product</p> <p>- Determines the method by which the concentration value is represented when a mixture two products, A & B, are being measured. (See Section 8.4 on page 76 for more details)</p> <p>Format : Unsigned Integer</p> <p>Range : 0 = % of Product A 1 = % of Product B</p> <p>Default Value : 0</p>
1018	<p>Concentration Coefficient #5</p> <p>- Definition of the carrier (Product B) when performing the General Concentration calculation. (See section 8.4 on page 76 for details)</p> <p>Format : Unsigned Integer</p> <p>Range: 0 = Pure Water (998.2 kg/m³ @ 20°C) 1 = Town Water (999.7 kg/m³ @ 20°C) 2 = Other.</p> <p>Default Value : 0</p>
1019	<p>CT Density Mode</p> <p>- The mode by which the density value is generated. See section 8.3 on page 75 for details.</p> <p>Format : Unsigned Integer</p> <p>Range: 0 = Actual (Measured Density) 1 = Fixed (Entered at register No. 3057) 2 = Referred.</p> <p>Default Value : 0</p>

Register No. Description

1020

Mass Flow Units

- The units setting in this register determine the scaling factor of the Mass Flow reading and some other related values (see the input and holding register definitions for details)

Format : Unsigned Integer

Range :

0	= User Defined Units (see Section 8.7 on page 77)
17	= g / second
18	= g / minute
19	= g / hour
20	= g / day
33	= kg / second
34	= kg / minute
35	= kg / hour
36	= kg / day
49	= metric Tonnes / second
50	= metric Tonnes / minute
51	= metric Tonnes / hour
52	= metric Tonnes / day
65	= oz / second
66	= oz / minute
67	= oz / hour
68	= oz / day
81	= lb / second
82	= lb / minute
83	= lb / hour
84	= lb / day

Default Value : 33

1021 Density Units

- The units setting in this register determine the scaling factor of the Density reading and some other related values (see the input and holding register definitions for details)

Format : Unsigned Integer

Range :	0	= User Defined Units (see Section 8.7 on page 77)
	17	= g / cm ³
	18	= g / dm ³
	19	= g / litre
	20	= g / m ³
	21	= g / in ³
	22	= g / ft ³
	23	= g / Gallon (US)
	24	= g / Gallon (Imperial)
	33	= kg / cm ³
	34	= kg / dm ³
	35	= kg / litre
	36	= kg / m ³
	37	= kg / in ³
	38	= kg / ft ³
	39	= kg / Gallon (US)
	40	= kg / Gallon (Imperial)
	49	= metric Tonnes / cm ³
	50	= metric Tonnes / dm ³
	51	= metric Tonnes / litre
	52	= metric Tonnes / m ³
	53	= metric Tonnes / in ³
	54	= metric Tonnes / ft ³
	55	= metric Tonnes / Gallon (US)
	56	= metric Tonnes / Gallon (Imperial)
	65	= oz / cm ³
	66	= oz / dm ³
	67	= oz / litre
	68	= oz / m ³
	69	= oz / in ³
	70	= oz / ft ³
	71	= oz / Gallon (US)
	72	= oz / Gallon (Imperial)
	81	= lb / cm ³
	82	= lb / dm ³
	83	= lb / litre
	84	= lb / m ³
	85	= lb / in ³
	86	= lb / ft ³
	87	= lb / Gallon (US)
	88	= lb / Gallon (Imperial)
	97	= SG

Default Value : 36

Register No. Description

1022

Mass Total Units

CT

- The units setting in this register determine the scaling factor of the Mass Total reading and some other related values (see the input and holding register definitions for details)

Format : Unsigned Integer

Range : 0 = User Defined Units (see Section 8.7 on page 77)
 16 = g
 32 = kg
 48 = metric Tonnes
 64 = oz
 80 = lb

Default Value : 32

1023

Volume Total Units

CT

- The units setting in this register determine the scaling factor of the Volume Total reading and some other related values (see the input and holding register definitions for details)

Format : Unsigned Integer

Range : 0 = User Defined Units (see Section 8.7 on page 77)
 16 = cm³
 32 = dm³
 48 = litre
 64 = m³
 80 = in³
 96 = ft³
 112 = Gallon (US)
 128 = Gallon (Imperial)

Default Value : 64

1024

Volume Flow Units

- The units setting in this register determine the scaling factor of the Volume Flow reading and some other related values (see the input and holding register definitions for details)

Format : Unsigned Integer

Range :	0	= User Defined Units (see Section 8.7 on page 77)
	17	= cm ³ / second
	18	= cm ³ / minute
	19	= cm ³ / hour
	20	= cm ³ / day
	33	= dm ³ / second
	34	= dm ³ / minute
	35	= dm ³ / hour
	36	= dm ³ / day
	49	= litre / second
	50	= litre / minute
	51	= litre / hour
	52	= litre / day
	65	= m ³ / second
	66	= m ³ / minute
	67	= m ³ / hour
	68	= m ³ / day
	81	= in ³ / second
	82	= in ³ / minute
	83	= in ³ / hour
	84	= in ³ / day
	97	= ft ³ / second
	98	= ft ³ / minute
	99	= ft ³ / hour
	100	= ft ³ / day
	113	= Gallon (US) / second
	114	= Gallon (US) / minute
	115	= Gallon (US) / hour
	116	= Gallon (US) / day
	129	= Gallon (Imperial) / second
	130	= Gallon (Imperial) / minute
	131	= Gallon (Imperial) / hour
	132	= Gallon (Imperial) / day

Default Value : 65

1025

Temperature Units

- The units setting in this register determine the scaling factor of the Temperature reading and some other related values (see the input and holding register definitions for details)













Format : Unsigned Integer















Range :	16	= Degrees Celsius (°C)
	32	= Degrees Fahrenheit (°F)
	48	= Kelvin (K)







Default Value : 16

Register No.	Description
1026	<p>Velocity Units</p> <p>- The units setting in this register determine the scaling factor of the Velocity reading (see the input and holding register definitions for details)</p> <p>Format : Unsigned Integer</p> <p>Range : 16 = m / second 32 = ft / second</p> <p>Default Value : 16</p>
1027	<p>Additional Totaliser Source</p> <p>- The additional totaliser acts as a batch counter recording a sub-total of one of the four main totalisers. The setting of this register determines which of the four main totalisers is the source for the Additional Totaliser. The Additional Totaliser can be reset individually from the main totalisers using Output Status Register 1004. The Additional Totaliser is also reset when the main totalisers are reset using Output Status register 1003.</p> <p>Format : Unsigned Integer</p> <p>Range : 0 = Disabled 1 = Mass Total 2 = Volume Total 3 = Concentration 1 Total 4 = Concentration 2 Total</p> <p>Default Value : 0</p>
1028	<p>Density Calibration Product Type</p> <p>- The fluid type defined for the Density calibration commands (See Output Status Register Nos. 1011-1013). See Section 8.2 on page 72 for further details about the density calibration procedure.</p> <p>Format : Unsigned Integer</p> <p>Range : 0 = Empty 1 = Pure Water (998.2 kg/m³ @ 20°C) 2 = Town Water (999.7 kg/m³ @ 20°C) 3 = Other</p> <p>Default Value : 0</p>
1029	<p>Concentration 2 Function</p> <p>- Determines the type of measurement calculation that the meter performs for Concentration 2. Can only be activated by means of the Concentration Password register No.7007. See section 8.4 on page 76 for details.</p> <p>Format : Unsigned Integer</p> <p>Range : 0 = De-activated (Option NOT Installed) 1 = Off 2 = °Brix 3 = % Mass (General Concentration) 4 = °Baumé 144.3 5 = °Baumé 145.0 6 = % NaOH 7 = °Plato 8 = % Volume (General Concentration) 9 = °API</p> <p>Default Value : 0</p>

Register No.	Description
1030	<p>Concentration 2 Product</p> <p>- Determines the method by which the concentration value is represented when a mixture two products, A & B, are being measured. (See Section 8.4 on page 76 for more details)</p> <p>Format : Unsigned Integer</p> <p>Range : 0 = % of Product A 1 = % of Product B</p> <p>Default Value : 0</p>
1031	<p>Calibration Coefficient CF25</p> <p>- One of the coefficients used to accurately calculate the values measured by the sensor, defined during the manufacturing process.</p> <p>Format : Integer</p> <p>Range: 0 to 1</p> <p>Default value: 0</p>
1032	<p>Year of Manufacture</p> <p>- Year that the mass flowmeter was manufactured. A two digit format is used, starting at the year 2000</p> <p>Format: Integer</p> <p>Range: 0 to 99</p> <p>Default value: 0</p>
3001 / 3002	<p>Calibration Coefficient CF1</p> <p>- One of the coefficients used to accurately calculate the values measured by the sensor, defined during the manufacturing process.</p> <p>Format : Floating Point</p> <p>Range : -40 to +200</p> <p>Default Value : 20</p>
3003 / 3004	<p>Calibration Coefficient CF2</p> <p>- One of the coefficients used to accurately calculate the values measured by the sensor, defined during the manufacturing process.</p> <p>Format : Floating Point</p> <p>Range : 100 to 1000</p> <p>Default Value : 750</p>
3005 / 3006	<p>Calibration Coefficient CF3</p> <p>- One of the coefficients used to accurately calculate the values measured by the sensor, defined during the manufacturing process.</p> <p>Format : Floating Point</p> <p>Range : 100 to 1000</p> <p>Default Value : 300</p>

Register No.	Description
3007 / 3008	<p>Calibration Coefficient CF4</p> <p>- One of the coefficients used to accurately calculate the values measured by the sensor, defined during the manufacturing process.</p> <p>Format : Floating Point</p> <p>Range : -100,000 to + 100,000</p> <p>Default Value : 0</p>
	<p></p> <p></p>
3009 / 3010	<p>Calibration Coefficient CF5</p> <p>- One of the coefficients used to accurately calculate the values measured by the sensor, defined during the manufacturing process.</p> <p>Format : Floating Point</p> <p>Range : 0.0001 to 90,000,000</p> <p>Default Value : Dependant on Sensor Settings (See Appendix D)</p>
	<p></p> <p></p>
3011 / 3012	<p>Calibration Coefficient CF6</p> <p>- One of the coefficients used to accurately calculate the values measured by the sensor, defined during the manufacturing process.</p> <p>Format : Floating Point</p> <p>Range : -10,000,000 to +10,000,000</p> <p>Default Value : 0</p>
	<p></p> <p></p>
3013 / 3014	<p>Calibration Coefficient CF7</p> <p>- One of the coefficients used to accurately calculate the values measured by the sensor, defined during the manufacturing process.</p> <p>Format : Floating Point</p> <p>Range : -10,000,000 to +10,000,000</p> <p>Default Value : 0</p>
	<p></p> <p></p>
3015 / 3016	<p>Calibration Coefficient CF8</p> <p>- One of the coefficients used to accurately calculate the values measured by the sensor, defined during the manufacturing process.</p> <p>Format : Floating Point</p> <p>Range : -10,000,000 to +10,000,000</p> <p>Default Value : 0</p>
	<p></p> <p></p>
3017 / 3018	<p>Calibration Coefficient CF9</p> <p>- One of the coefficients used to accurately calculate the values measured by the sensor, defined during the manufacturing process.</p> <p>Format : Floating Point</p> <p>Range : -10,000 to +10,000</p> <p>Default Value : 0</p>
	<p></p>
3019 / 3020	<p>Calibration Coefficient CF10</p> <p>- One of the coefficients used to accurately calculate the values measured by the sensor, defined during the manufacturing process.</p> <p>Format : Floating Point</p> <p>Range : 1 to 100,000</p> <p>Default Value : 1000</p>
	<p></p>

Register No.	Description
3021 / 3022	<p>Calibration Coefficient CF11</p> <p>- One of the coefficients used to accurately calculate the values measured by the sensor, defined during the manufacturing process.</p> <p> </p> <p>Format : Floating Point Range : -10,000 to +10,000 Default Value : 0</p>
3023 / 3024	<p>Calibration Coefficient CF12</p> <p>- One of the coefficients used to accurately calculate the values measured by the sensor, defined during the manufacturing process.</p> <p> </p> <p>Format : Floating Point Range : -1,000,000 to +1,000,000 Default Value : 0</p>
3025 / 3026	<p>Calibration Coefficient CF13</p> <p>- One of the coefficients used to accurately calculate the values measured by the sensor, defined during the manufacturing process.</p> <p> </p> <p>Format : Floating Point Range : -1,000,000 to +1,000,000 Default Value : 0</p>
3027 / 3028	<p>Calibration Coefficient CF14</p> <p>- One of the coefficients used to accurately calculate the values measured by the sensor, defined during the manufacturing process.</p> <p> </p> <p>Format : Floating Point Range : -1,000,000 to +1,000,000 Default Value : 0</p>
3029 / 3030	<p>Calibration Coefficient CF15</p> <p>- One of the coefficients used to accurately calculate the values measured by the sensor, defined during the manufacturing process.</p> <p> </p> <p>Format : Floating Point Range : -10,000,000 to +10,000,000 Default Value : 0</p>
3031 / 3032	<p>Calibration Coefficient CF16</p> <p>- One of the coefficients used to accurately calculate the values measured by the sensor, defined during the manufacturing process.</p> <p> </p> <p>Format : Floating Point Range : -10,000,000 to +10,000,000 Default Value : 0</p>
3033 / 3034	<p>Calibration Coefficient CF17</p> <p>- One of the coefficients used to accurately calculate the values measured by the sensor, defined during the manufacturing process.</p> <p> </p> <p>Format : Floating Point Range : -1,000,000 to +1,000,000 Default Value : 0</p>





Register No.	Description
3035 / 3036	<p>Calibration Coefficient CF18</p> <p>- One of the coefficients used to accurately calculate the values measured by the sensor, defined during the manufacturing process.</p> <p>Format : Floating Point</p> <p>Range : -1,000,000 to +1,000,000</p> <p>Default Value : 0</p>
	<p></p> <p></p>
3037 / 3038	<p>Calibration Coefficient CF19</p> <p>- One of the coefficients used to accurately calculate the values measured by the sensor, defined during the manufacturing process.</p> <p>Format : Floating Point</p> <p>Range : -10,000,000 to +10,000,000</p> <p>Default Value : 0</p>
	<p></p> <p></p>
3039 / 3040	<p>Calibration Coefficient CF20</p> <p>- One of the coefficients used to accurately calculate the values measured by the sensor, defined during the manufacturing process.</p> <p>Format : Floating Point</p> <p>Range : -1,000,000 to +1,000,000</p> <p>Default Value : 0</p>
	<p></p> <p></p>
3041 / 3042	<p>Meter Correction Factor</p> <p>- A user defined correction factor for adjusting the flow rate reading in situ to compensate for local process variations.</p> <p>Format : Floating Point</p> <p>Range : -100% to +100%</p> <p>Default Value : 0</p>
	<p></p>
3043 / 3044	<p>Pipe Diameter</p> <p>- This setting is used in conjunction with the volume flow rate to determine the velocity of the flow through the pipe. By default this is the internal diameter of the measuring tube of the sensor being used. It can be changed to determine the velocity of flow through a preceding piece of pipe work by entering the internal diameter of that pipe work. This value is scaled in millimetres.</p> <p>Format : Floating Point</p> <p>Range : 1 mm to 500 mm</p> <p>Default Value : Depends Upon Sensor Size (See Appendix D).</p>
3045 / 3046	<p>Measurement Time Constant</p> <p>- The filtering period used to remove noise from the Mass Flow reading.</p> <p>Format : Floating Point</p> <p>Range : 0.2 to 20 seconds</p> <p>Default Value : 4 seconds</p>











Register No.	Description
3047 / 3048	<p>Low Flow Threshold</p> <p>- The flow rate (as a percentage of nominal flow) below which the Mass Flow reading is automatically set to 0.</p> <p>CT</p> <p>Format : Floating Point</p> <p>Range : 0% to 10%</p> <p>Default Value : 0.5%</p>
3049 / 3050	<p>User Flow Offset</p> <p>- A fixed offset that the user can employ to test the associated systems. This value is scaled according to the Value of the Mass Flow Units (see Holding Register No.1020) . It is reset when a zero calibration is performed (Output Status Register No. 1002).</p> <p>CT</p> <p>Format : Floating Point</p> <p>Range : -11.945 kg/sec to +11.945 kg/sec.</p> <p>Default Value : 0 kg/sec</p>
3051 / 3052	<p>Process Control Maximum Limit</p> <p>- This value determines the level above which the control function will become active. The scaling and range of this value is dependant upon the setting of the control condition (see Holding Register No 1010) . See Section 8.8 on page 78 for more details.</p> <p>Format : Floating Point</p> <p>Range : Dependant on the Control Condition and Scaling Units</p> <p>Default Value : 2000 kg/m³ or +100.0°C</p>
3053 / 3054	<p>Process Control Minimum Limit</p> <p>- This value determines the level below which the control function will become active. The scaling and range of this value is dependant upon the setting of the control condition (see Holding Register No 1010) . See Section 8.8 on page 78 for more details.</p> <p>Format : Floating Point</p> <p>Range : Dependant on the Control Condition and Scaling Units</p> <p>Default Value : 500 kg/m³ or 0.0°C</p>
3055 / 3056	<p>Referred Density Reference Temperature</p> <p>- The reference temperature to which density reading is referred when the Density Mode (see Holding Register 1019) is set to "Referred". This value is scaled by the setting of the Temperature Units (see holding register No. 1025) . Refer to Section 8.3 on page 75 for further details on the use of the Referred Density Mode.</p> <p>Format : Floating Point</p> <p>Range : -200 °C to + 500 °C</p> <p>Default Value : +20 °C</p>











Register No.	Description
3057/ 3058	<p>Fixed Density Value</p> <p>- The fixed value of the density that is used by the compensation and concentration calculations when the Density Mode (see Holding Register 1019) is set to "Fixed". This value is scaled by the setting of the Density Units (see holding register No. 1021) . Refer to Section 8.3 on page 75 for further details on the use of the Fixed Density Mode.</p> <p>Format : Floating Point Range : 0.08 kg/m³ to 3000 kg/m³ Default Value : 998.2 kg/m³</p>
3059 / 3060	<p>Referred Density Slope</p> <p>- The slope used to extrapolate the density from the measured temperature to the referred temperature when the Density Mode (see Holding Register 1019) is set to "Referred". This value is scaled by the setting of the Density Units (see holding register No. 1021) and the Temperature Units (see holding register No. 1025). Refer to Section 8.3 on page 75 for further details on the use of the Referred Density Mode.</p> <p>Format : Floating Point Range : 0 kg/m³/°C to 65 kg/m³/°C Default Value : 0 kg/m³/°C</p>
3061 / 3062	<p>Concentration Coefficient #2</p> <p>- One of the coefficients used to extrapolate general concentration values from the Density and Temperature readings. See Section 8.4 on page 76 for more details.</p> <p>Format : Floating Point Range : -90,000,000 to + 90,000,000 Default Value : 0</p>
3063 / 3064	<p>Concentration Coefficient #3</p> <p>- One of the coefficients used to extrapolate general concentration values from the Density and Temperature readings. See Section 8.4 on page 76 for more details.</p> <p>Format : Floating Point Range : -90,000,000 to + 90,000,000 Default Value : 0</p>
3065 / 3066	<p>Concentration Coefficient #4</p> <p>- One of the coefficients used to extrapolate general concentration values from the Density and Temperature readings. See Section 8.4 on page 76 for more details.</p> <p>Format : Floating Point Range : -90,000,000 to + 90,000,000 Default Value : 0</p>

Register No.	Description
3067 / 3068	<p>Concentration Coefficient #6</p> <p>- One of the coefficients used to extrapolate general concentration values from the Density and Temperature readings. See Section 8.4 on page 76 for more details.</p> <p>Format : Floating Point</p> <p>Range : -90,000,000 to + 90,000,000</p> <p>Default Value : 0</p>
3069 / 3070	<p>Concentration Coefficient #7</p> <p>- One of the coefficients used to extrapolate general concentration values from the Density and Temperature readings. See Section 8.4 on page 76 for more details.</p> <p>Format : Floating Point</p> <p>Range : -90,000,000 to + 90,000,000</p> <p>Default Value : 0</p>
3071 / 3072	<p>Concentration Coefficient #8</p> <p>- One of the coefficients used to extrapolate general concentration values from the Density and Temperature readings. See Section 8.4 on page 76 for more details.</p> <p>Format : Floating Point</p> <p>Range : -90,000,000 to + 90,000,000</p> <p>Default Value : 0</p>
3073 / 3074	<p>Concentration Coefficient #9</p> <p>- One of the coefficients used to extrapolate general concentration values from the Density and Temperature readings. See Section 8.4 on page 76 for more details.</p> <p>Format : Floating Point</p> <p>Range : -90,000,000 to + 90,000,000</p> <p>Default Value : 0</p>
3075 / 3076	<p>Concentration Coefficient #10</p> <p>- One of the coefficients used to extrapolate general concentration values from the Density and Temperature readings. See Section 8.4 on page 76 for more details.</p> <p>Format : Floating Point</p> <p>Range : -90,000,000 to + 90,000,000</p> <p>Default Value : 0</p>
3077 / 3078	<p>Concentration Coefficient #11</p> <p>- One of the coefficients used to extrapolate general concentration values from the Density and Temperature readings. See Section 8.4 on page 76 for more details.</p> <p>Format : Floating Point</p> <p>Range : -90,000,000 to + 90,000,000</p> <p>Default Value : 0</p>

Register No.	Description
3079 / 3080	<p>Concentration Coefficient #12</p> <ul style="list-style-type: none"> - One of the coefficients used to extrapolate general concentration values from the Density and Temperature readings. See Section 8.4 on page 76 for more details. <p>Format : Floating Point Range : -90,000,000 to + 90,000,000 Default Value : 0</p>
3081 / 3082	<p>Concentration 1 Offset</p> <ul style="list-style-type: none"> - A fixed offset that the user can apply any of the Concentration 1 calculations made by the MFC010. See Section 8.4 on page 76 for more details. <p>Format : Floating Point Range : -10% to +10% Default Value : 0 %</p>
3083 / 3084	<p>User Defined Mass Total Units Scaling</p> <ul style="list-style-type: none"> - The scaling factor used for the user defined Mass Total units (see Holding Register No. 1022) . See Section 8.7 on page 77 for more details. <p>Format : Floating Point Range : 0.00000001 to 1,000 Default Value : 1</p>
3085 / 3086	<p>User Defined Volume Total Units Scaling</p> <ul style="list-style-type: none"> - The scaling factor used for the user defined Volume Total units (see Holding Register No. 1023) . See Section 8.7 on page 77 for more details. <p>Format : Floating Point Range : 0.00000001 to 1,000 Default Value : 1</p>
3087 / 3088	<p>User Defined Mass Flow Units Scaling</p> <ul style="list-style-type: none"> - The scaling factor used for the user defined Mass Flow units (see Holding Register No. 1020) . See Section 8.7 on page 77 for more details. <p>Format : Floating Point Range : 0.00000001 to 1,000 Default Value : 1</p>
3089 / 3090	<p>User Defined Volume Flow Units Scaling</p> <ul style="list-style-type: none"> - The scaling factor used for the user defined Volume Flow units (see Holding Register No. 1024) . See Section 8.7 on page 77 for more details. <p>Format : Floating Point Range : 0.00000001 to 1,000 Default Value : 1</p>

Register No.	Description
3091 / 3092	<p>User Defined Density Units Scaling</p> <ul style="list-style-type: none"> - The scaling factor used for the user defined Density units (see Holding Register No. 1021) . See Section 8.7 on page 77 for more details. <p>Format : Floating Point Range : 0.00000001 to 1,000 Default Value : 1</p>
3093 / 3094	<p>Calibration Density</p> <ul style="list-style-type: none"> - The Density value used by the calibration process when "Other" is selected as the calibration type. This value is scaled according to the setting of the Density Units (see Holding Register No. 1021). See Section 8.2 on page 72 for more details. <p>Format : Floating Point Range : 0 kg/m³ to 3000 kg/m³ Default Value : 0 kg/m³</p>
3095 / 3096	<p> Temperature at Last Zero Calibration</p> <ul style="list-style-type: none"> - A stored value of the temperature reading during the last zero Mass flow calibration. The value is scaled according to the setting of the "Temperature Units" (see Holding Register No.1025) <p>Format : Floating Point Range : -200 °C to + 500 °C</p>
3097 / 3098	<p> Sensor Maximum Temperature Specification</p> <ul style="list-style-type: none"> - The maximum temperature rating for the Sensor. The value is scaled according to the setting of the "Temperature Units" (see Holding Register No.1025) <p>Format : Floating Point Range : 0 °C to + 500 °C Default Value : Dependant on Sensor Settings (See Appendix D)</p>
3099 / 3100	<p> Sensor Minimum Temperature Specification</p> <ul style="list-style-type: none"> - The minimum temperature rating for the Sensor. The value is scaled according to the setting of the "Temperature Units" (see Holding Register No.1025) <p>Format : Floating Point Range : -200 °C to + 50 °C Default Value : Dependant on Sensor Settings (See Appendix D)</p>
3101 / 3102	<p> Pressure Suppression Time</p> <ul style="list-style-type: none"> - The period of application of the Pressure Suppression, during which the Pressure Suppression Cut-off is applied (see holding register 3103). See section 8.10 on page 79 for further details of Pressure Suppression. <p>Format : Floating Point Range : 0.0 to 20.0 Seconds Default Value : 0.0 Seconds</p>

Register No.	Description
3103 / 3104	<p>Pressure Suppression Cut-off</p> <p> - When Pressure Suppression is active, the Cut-off value that is applied in addition to the Low Flow Threshold (see Holding Register No. 3047). See section 8.10 on page 79 for further details of Pressure Suppression.</p> <p>Format : Floating Point Range : 0.0% to 10.0% Default Value : 0.0 %</p>
3105 / 3106	<p>Density Averaging</p> <p> - The filter period of the Density reading.</p> <p>Format : Floating Point Range : 1.0 to 20.0 Seconds Default Value : 10.0 Seconds</p>
3107 / 3108	<p>Concentration 2 Offset</p> <p>- A fixed offset that the user can apply any of the Concentration 2 calculations made by the MFC010. See Section 8.4 on page 76 for more details.</p> <p>Format : Floating Point Range : -10% to +10% Default Value : 0 %</p>
3109 / 3110	<p>Calibration Coefficient #21</p> <p> - One of the coefficients used to accurately calculate the values measured by the sensor, defined during the manufacturing process.</p> <p> Format : Floating Point Range : 0.0 to 10 Default Value : 0</p>
3111 / 3112	<p>Calibration Coefficient #22</p> <p> - One of the coefficients used to accurately calculate the values measured by the sensor, defined during the manufacturing process.</p> <p> Format : Floating Point Range : 0.0 to 10 Default Value : 0</p>
3113 / 3114	<p>Calibration Coefficient #23</p> <p> - One of the coefficients used to accurately calculate the values measured by the sensor, defined during the manufacturing process.</p> <p> Format : Floating Point Range : 0.0 to 10 Default Value : 0</p>
3115 / 3116	<p>Calibration Coefficient #24</p> <p> - One of the coefficients used to accurately calculate the values measured by the sensor, defined during the manufacturing process.</p> <p> Format : Floating Point Range : 0.0 to 10 Default Value : 0</p>

Register No.	Description
3117 / 3118	<p>Calibration Coefficient #26</p> <ul style="list-style-type: none"> - One of the coefficients used to accurately calculate the values measured by the sensor, defined during the manufacturing process. <p>   </p> <p>Format : Floating Point Range : 0.0 to 10 Default Value : 0</p>
3119 / 3120	<p>Calibration Coefficient #27</p> <ul style="list-style-type: none"> - One of the coefficients used to accurately calculate the values measured by the sensor, defined during the manufacturing process. <p>   </p> <p>Format : Floating Point Range : 0.0 to 10 Default Value : 0</p>
3121 / 3122	<p>2 Phase Warning level</p> <ul style="list-style-type: none"> - Defines the acceptable level of 2 phase signal. Set to zero to disable function <p>Format : Floating Point Range : 0.0 to 1000.0 Default Value : 0</p>
7001 / 7002	<p>MFC010 Serial Number</p> <ul style="list-style-type: none"> - The unique serial number of the MFC010. This is assigned during manufacture and is used to track the history of the device <p>   </p> <p>Format : Unsigned Long Integer Range : 0 to 16777215 Default Value : 0</p>
7003 / 7004	<p>System Serial Number</p> <ul style="list-style-type: none"> - The unique serial number of the MFC010 + Sensor. This is assigned during manufacture and is used to track the history of the device <p>   </p> <p>Format : Unsigned Long Integer Range : 0 to 16777215 Default Value : 0</p>
7005 / 7006	<p>Sensor Serial Number</p> <ul style="list-style-type: none"> - The unique serial number of the sensor. This is assigned during manufacture and is used to track the history of the device <p>   </p> <p>Format : Unsigned Long Integer Range : 0 to 16777215 Default Value : 0</p>
7007 / 7008	<p>Enable Concentration Measurement</p> <ul style="list-style-type: none"> - Writing the correct password to this register group will enable the concentration measurement options. See section 8.4 on page 76 for details <p>Format : Unsigned Long Integer Range : 0 to 16777215 Default Value : 0</p>

8.1 Mass Flow Zero Calibration

All KROHNE mass flow meters are supplied with an accurate calibration that is performed at the factory prior to despatch. However, due to process and installation variations that cannot be accounted for by factory calibration, it is always good practice to perform regular zero calibrations on the sensor to ensure the accuracy of the results. The simple process for performing the zero calibration is laid out below.

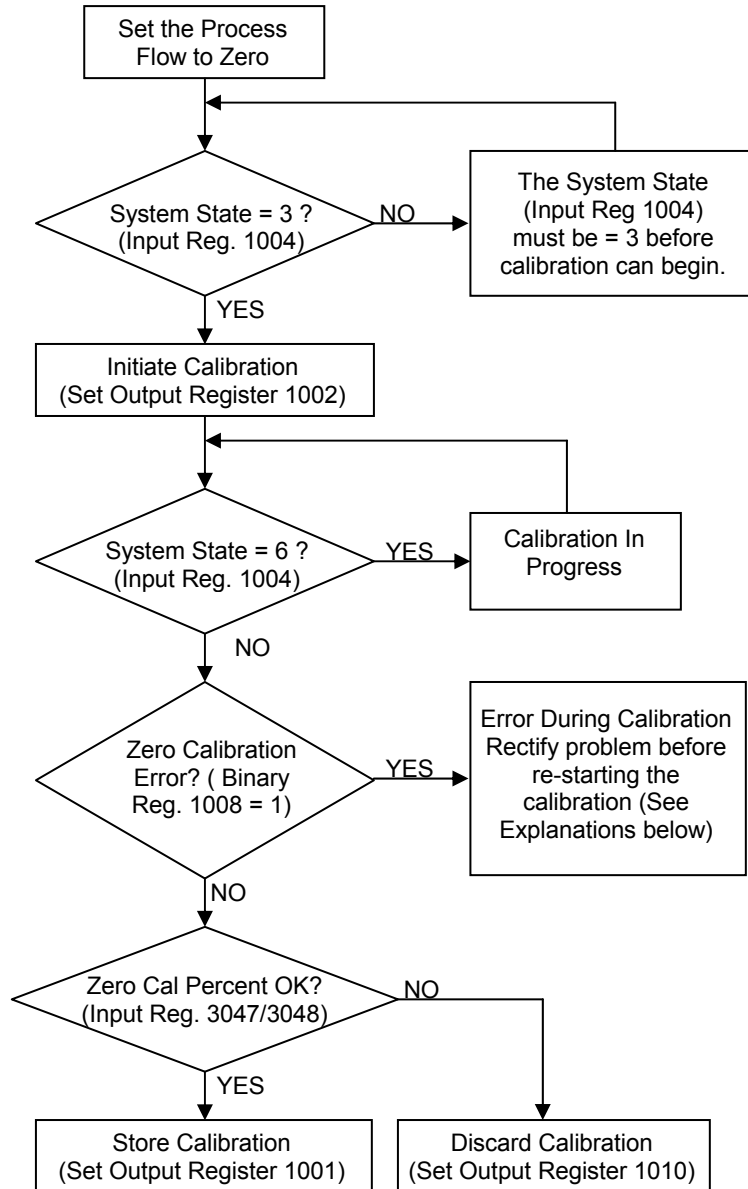

The new calibration must be stored in memory (set Output Register 1001) before it will be used in the Mass Flow measurement result. The Zero calibration value can be monitored during the calibration process by reading the “Zero Calibration Percent” Input Register (Input register No. 3047/3048). This will provide a floating-point value that represents the zero as a percentage of the nominal flow of the sensor. During calibration the register will return the actively measured zero. When not calibrating, this register will indicate the stored calibration value.

The “Zero Calibration Status Flag”, held in Binary Input register no. 1008, indicates when the system has detected an error during the calibration process and has subsequently abandoned the calibration operation. There are two reasons for this to occur. The first will occur when the flow rate during calibration exceeds $\pm 10\%$ of the sensors nominal flow. The second will occur when the system is not in “Measurement” mode, during the calibration period. At the instant the system mode changes from “Measurement” the Zero Calibration process will be terminated, this is also the case if the system is not in “Measurement” mode when the calibration is initiated.

8.2 Density Calibration

Although an accurate calibration of density is performed during the manufacturing process, this factory calibration is performed on Air and Water and as such covers a large range of possible measurement due to the wide-ranging applications into which the Optimass sensors are installed. It is always advisable, if possible, for the user/installer to perform a density calibration on the actual process fluid, preferably at the two extremes of the process density. This will provide a much greater degree of accuracy for the target application process.

The User can choose to perform either a “One point” or “Two point” calibration. The “Two point” calibration is best to be used when there are two clearly defined process densities, the single point is more appropriate when there is one, or a less clearly defined or narrow range of process densities. The procedure for the “One point” and “Two point” calibrations is very much the same, the “Two point” calibration merely being a case of repeating the “Single point” calibration, though the user should note that the output status registers used to initiate the “One point” and “Two point” calibrations are different (see section 7.2).

The User can choose to use one of three preset product types (see Holding Register No 1028) for which the system will use internally programmed polynomials to determine the correct density at the measured process temperature. Alternatively the user can select the fourth product type, “Other”, and enter a density value into the calibration density holding register (see Holding Register No 3093). During the calibration process the system will measure the tube parameters for the selected process density and temperature and store them for use in the measurement algorithms.

Should it be necessary the user can elect to restore the original factory calibration values by selecting output register number 1014. The user must then save the restored configuration to the non-volatile memory by selecting output register number 1001.

When a “One point” calibration is performed for the first time, the MFC010 will replace the factory calibrated “Empty” value with the new user calibration value. Subsequently, the MFC010 will use the newly calibrated value to replace the calibration value that is the closest to it.

NB. The OPTIGAS 5000 meter does not measure density, so any attempt to perform a density calibration will be rejected and will result in an error condition in the density status.

The procedure for performing a single point density calibration is as follows.

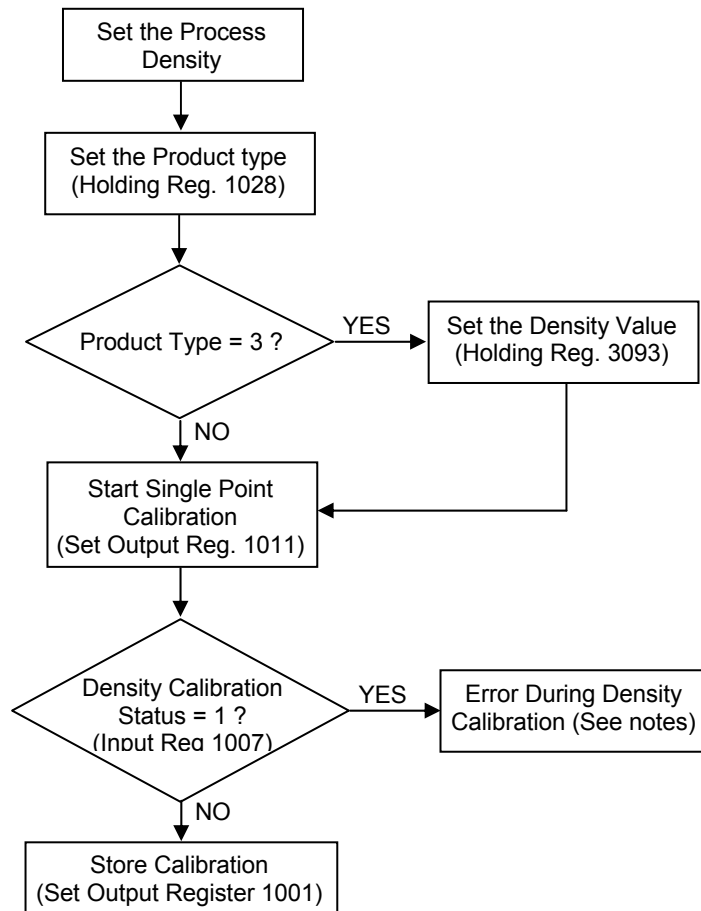

An error flag is set in the “Density Calibration” input status register when the measured tube frequency does not correlate with the value/product type of the calibration density entered by the user (e.g. if the user requests a calibration of the “Air” type when the tube is full of process fluid.)

The procedure for performing a two point density calibration is as follows.

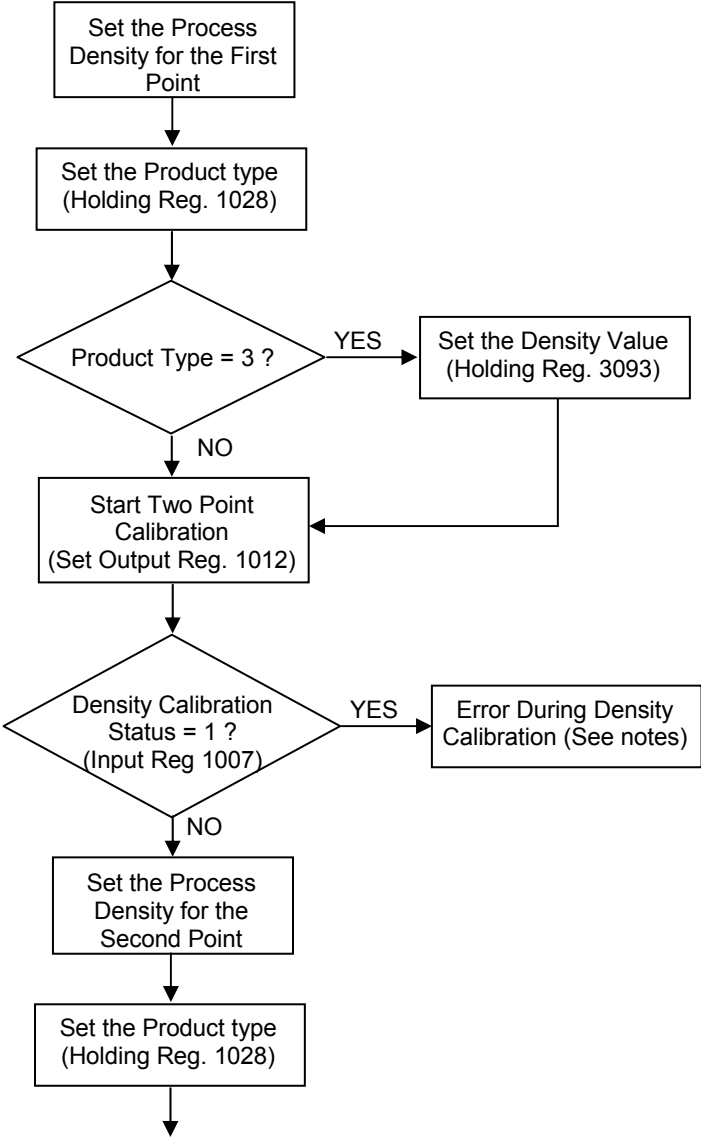

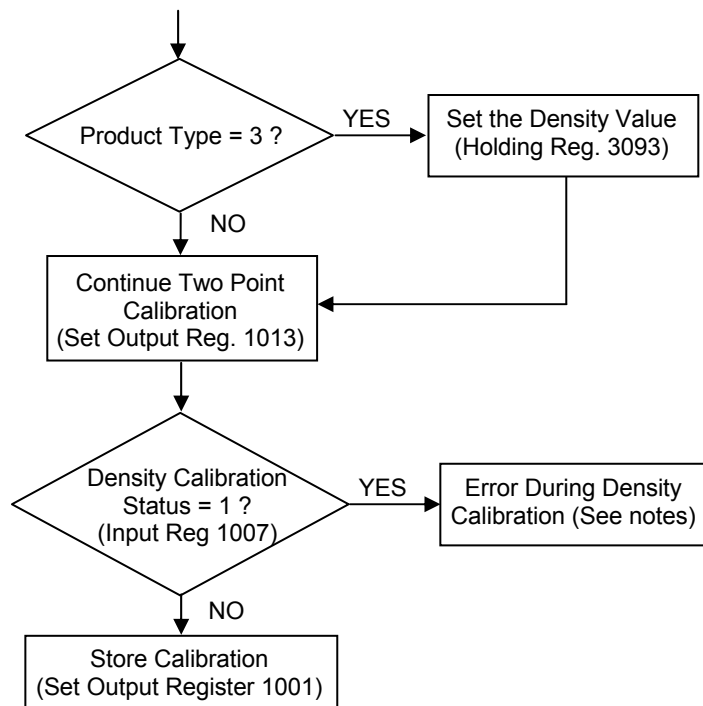

8.3 Fixed and Referred Density Operation

In addition to the directly measured Density, the MFC010 provides the user with two further modes of Density determination. These can be selected by setting the appropriate Density Mode value in Holding register no. 1019 (see section 7.5 on page 49). NB. The system will always use the actual measured density in the determination of the mass flow reading, regardless of the Density Mode setting.

The Fixed Density is used when direct density measurement is not required, to calculate the Volume and other density related measurement values. It can also be used to test Density related features such as the Internal Process control Mechanism (see section 8.8 on page 78). When the Density Mode is set to "Fixed" the value of the density is determined by the contents of the Fixed density register, accessed as Holding register no. 3057/ 3058 (see section 7.5 on page 49). This value is scaled according to the setting of the Density units, accessible as Holding Register no. 1021 (see section 7.5 on page 49).

In Referred Density mode, the MFC010 will extrapolate the measured density to a reference temperature based on a defined slope relationship. The reference temperature is set in Holding register no. 3055/3056 and is scaled to the Temperature units, which are set in Holding register No. 1025. The reference slope is defined in Holding register 3059/3060 and is scaled by Density Units/Temperature Units, e.g. g/cm³/°C.

For example, given a density of 1.233 g/cm³ is measured by the sensor at a process temperature of 37.8°C, if the density is referred back to 20°C using a slope of 0.025 g/cm³/°C then the displayed density will be $(37.8 - 20) \times 0.025 + 1.233 = 1.678 \text{ g/cm}^3$. i.e. a measured Density of 1.233 g/cm³ at 37.8°C is equated to a density of 1.678 g/cm³ at 20°C.

8.4 Concentration Measurement

Using the density and temperature measurement data the MFC010 is able to calculate the concentration of a number of standard and user defined process mixtures. This extra facility must be purchased in addition to the standard MFC010 software functionality. Consult the Optimass support team for details.

When the concentration features are enabled, the user will be provided with a complete manual that covers all of the aspects of concentration measurement in the Optimass series of sensors. This concentration manual was written in relation to the MFC050 converter but can equally be applied to the MFC010 as the functionality is the same. Along with the concentration manual the user will be provided with a software application that will automatically calculate the required coefficients from process data supplied by the user.

To enable the concentration measurement the user must write the unique sensor specific password value to Holding register number 7007/7008. (the value is a long integer and so must be written as two registers). The correct password value will be supplied by KROHNE upon purchase of the Concentration option. The lockout operation of the Concentration password is the same as described for the Supervisor passwords described below.

8.5 Using the System Protection Passwords

The MFC010 is protected by a series of features to prevent accidental or inadvertent alteration of the configuration and calibration settings. The "Supervisor" password, when activated, blocks all write operations to the Holding registers. The "Service" password, when activated, will block all write operations to any Holding register that directly affects the measurement values, principally the calibration coefficients. Registers that are protected by the "Service Password" are indicated in the Holding Register definitions with the ✕ symbol, refer to Section 7.5.

The "Service" password is always active when power is first applied to the MFC010. It can be disabled for 2 minutes by writing the correct code to the "Service" password register, Holding register No 1002. The status of the "Service" password can be determined by examining the condition of Input Binary status register number 1002. If the password register is written to before the 2 minute period of de-activation expires, then the 2 minute count will be restarted. The "Service" password is a fixed 16 bit code which may be obtained if necessary from the Optimass product support team, refer to your supplier for details. The "Service" password cannot be read from the Holding register, the MFC010 will return a "0" value when the "Service" password register is read.

The Supervisor password is by default de-activated. It can be activated by writing an appropriate 16 bit value to the "Supervisor" password register, Holding register NO 1001. The status of the "Supervisor" password can be determined by examining the condition of Input Binary status register number 1001. To de-activate the "Supervisor" password simply write the chosen password back to the "Supervisor" password register. The password protection will become effective as soon as the password is written, but the user must remember to perform a "Save to EEPROM" to ensure that the password condition is reloaded when the unit is next switched on. When activated the "Supervisor" password register will return an encoded version of the password value when read. If the password is forgotten or otherwise incorrectly recorded, the system can be unlocked by sending the encoded value to the Optimass product support team who will provide the correct password value, refer to your supplier for details.

Writing an incorrect value to a password register on three consecutive occasions will result in a 10 minute "lockout" of that register, i.e. subsequent writes to that register, whether with the correct password or not, will be rejected with an "Illegal Function" error response. See Section 5.6 on page 22 for details of the error response telegram formats.

8.6 Saving and Restoring Configuration settings

The contents of the holding registers (see section 7.5 on page 49) are stored in non-volatile EEPROM memory such that when power is applied to the MFC010 the previous configuration settings will be reloaded. When changing the settings of the holding registers the user must command the MFC010 to save the changes (using Output State Register No 1001, See section 7.2 on page 39 for details), before they are saved to the non-volatile memory. The altered values must be saved before they will affect the measurement values.

The Units settings and User defined unit scaling values are the exception to this rule, they will affect the transmitted value as soon they are changed. The changes must still be stored in the non-volatile EEPROM memory if they are to be restored on the next occasion that the MFC010 is switched on.

When changes have been made to the configuration but not stored in the non-volatile EEPROM memory the system will indicate this fact by setting the "Parameters Changed" flag, which can be interrogated by using command 7 (see section 6.7 on page 29) or accessing Input State register No. 1004 (see section 7.3 on page 41). This flag will be reset once the command to store the settings is acted upon.

The user can elect to discard the settings that have been written to the MFC010 if they have not been saved to the non-volatile EEPROM memory, in which case the previously stored settings will be reloaded from the non-volatile EEPROM memory. This is in effect the same as switching the MFC010 off and back on again. To discard the settings use Output State register No .1010 (see section 7.2 on page 39 for details).

8.7 Implementing User Defined Units

In order to provide a degree of flexibility for the Modbus interface when using the MFC010, a facility has been included to allow the operator to scale the transmitted values to an operator defined unit if the required units are not included in the list of standard units for each variable (see Holding Registers 1020 – 1026). To use the User Defined units simply set the units register for the required variable to "0" then write the required scaling factor to the appropriate register from Holding Register No 3083 to 3091. The scaling factor will rescale the transmitted value from the internal MFC010 units (see below) to the user defined scale. NB Be careful as this will change the scaling of all related variables that use the same units.

Internal Units :	Mass Total	g,	grammes
	Mass Flow	g/s,	grammes per second
	Density	g/cm ³ ,	grammes per centimetre cubed
	Volume Total	cm ³ ,	centimetres cubed
	Volume Flow	cm ³ /s,	centimetres cubed per second

For example, if the user wished to receive the transmitted Volume Total in "cubic yards" then the value stored in Holding register No 3085 should be 1.30795×10^{-6} (i.e. $1\text{yd}^3 = 764554.9 \text{cm}^3$, so $1\text{cm}^3 = 1.30795 \times 10^{-6} \text{yd}^3$).

8.8 Using the Internal Process Control Mechanism

The internal process control system permits the user to limit the measurement when the process conditions are outside of the prescribed limits as defined in the Internal Process Control settings.

The process conditions under which the control mechanism is employed are defined in the holding registers (see section 7.5 on page 49). Holding register No.1010 determines the source of the controlling variable, i.e. the process temperature or the process density. The contents of Holding registers 3051 and 3053 determine the minimum and maximum limits of the controlling variable, outside of which the process control mechanism will be applied.

When applied, the process control mechanism will perform one of three functions, defined by the setting of Holding register no 1009.

Holding Register 1009 = 1 : The Internal Process control mechanism is disabled

Holding Register 1009 = 2 : The Flow readings are forced to zero

Holding Register 1009 = 3 : The Flow readings are forced to zero and all of the totalisers are reset.

When the Internal Process control mechanism is active, i.e. the defined process condition is beyond the set limits, the "Process control active" bit in the Exception Status message (see section 6.7 on page 29) will be set. This status bit is also accessible in Discrete Input register no. 1009 (see section 7.3 on page 41).

8.9 Custody Transfer Applications

To provide added security for use in Custody transfer applications the MFC010 has been designed to include a Custody Transfer Password. This password will prevent any changes to those configuration variables (Holding registers) that have any effect on the measurement result. The Custody password is activated by writing a 16-bit password value of the user's choice to the Custody transfer password register (Holding Register No. 1003). When the Custody Transfer protection is activated it will be indicated in the Binary Input register Number 1003. Those configuration variables that are write protected by the Custody Transfer Password are indicated with the symbol **CT** in the Register definitions. The Custody transfer protection also extends to the resetting of certain Error flags, see section 9 for details.

Writing an incorrect value to a password register on three consecutive occasions will result in a 10 minute "lockout" of that register, i.e. subsequent writes to that register, whether with the correct password or not, will be rejected with an "Illegal Function" error response. See Section 5.6 on page 22 for details of the error response telegram formats.

8.10 Pressure Suppression

The Pressure Suppression feature has been included to permit the user to eliminate any influences on the measurement result of sudden termination of flow, such as when a valve is shut. When this occurs the propagation of pressure waves along the pipe work and through the meter may produce an “Over-shoot” or “ringing” effect, where the flow rate will oscillate backwards and forwards until it settles to a stable zero flow condition, as is indicated in the diagram below.

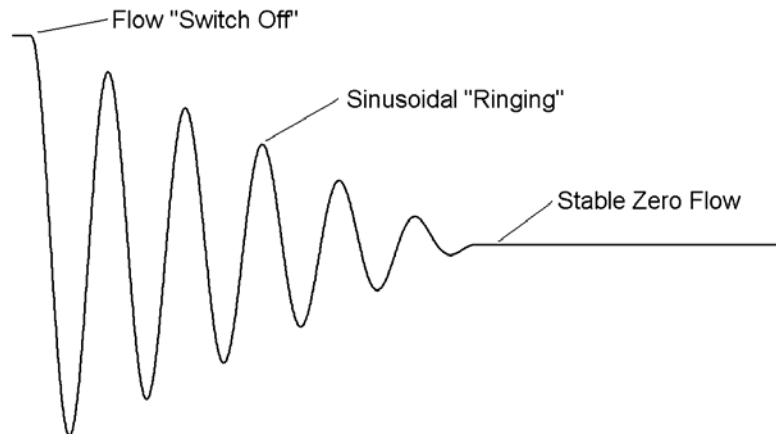

The amplitude and duration of the “Ringing” in proportion to the flow rate in the diagram above has been greatly exaggerated to provide a clear indication of what may occur. It appears at first glance that the positive and negative variations would cancel each other in any totaliser result, however, as the result is decaying the negative peaks will always be slightly larger than the positive peaks and will therefore accumulate a negative error in any totaliser result. This will of course become a positive error when the flow is in the opposite (negative) direction.

In most cases the amplitude of the ringing will be below the “Low Flow Threshold” (see Holding Register No 3047) and will therefore not influence the result. However, in some cases the amplitude of the ringing will be above the Low Flow Threshold and will still contribute to an error in the totaliser values (see figure below).

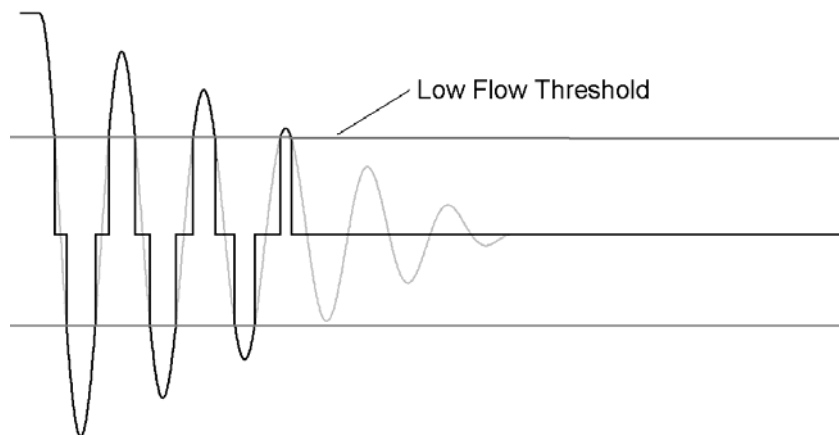

The Pressure Suppression function eliminates the effect of this over-shoot by increasing the “Low flow Threshold” for a short period of time. The pressure suppression function will be triggered when the flow rate first falls below the low flow threshold. For a set period of time, defined in Holding Register No 3101, the Pressure suppression threshold, defined in Holding Register No. 3103, will be added to the level of the Low flow threshold, as defined in Holding Register No. 3047. See figure below.

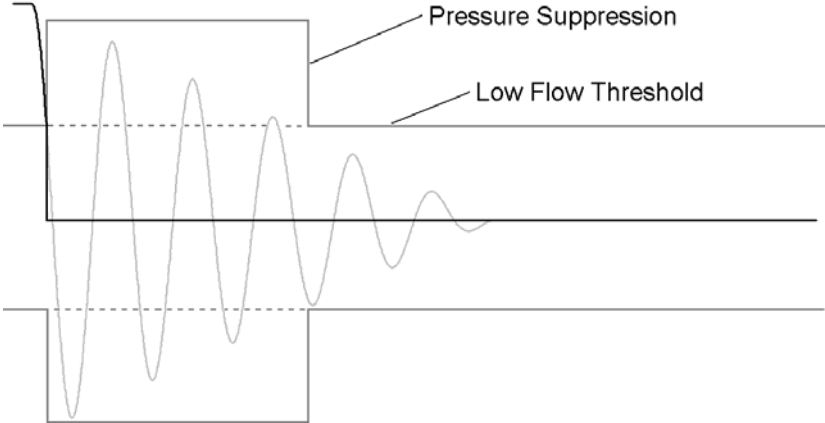

The amplitude, frequency and decay rate of the ringing effect will depend upon the flow rate prior to the Flow “Switch Off”, the rate at which the “Switch Off” occurs and the damping characteristics of the pipe work installation. For this reason, setting the parameters of the Pressure Suppression function is an empirical process that the installer must go through to optimise the operation to the target installation.

9. Error and Warning Messages

The error and warning flags generated by the MFC010 can be retrieved from Input register numbers 7001 to 7008. The Error and warning flags are split into two pairs of 32 bit long integer values (each filling two registers locations).

Some of the following Error and Warning flags are protected from being reset in Custody transfer applications when the custody transfer password is activated, these are indicated below by the **CT** symbol.





9.1 System Errors

The System Error flags, held as a long integer value in input registers 7001/7002, are an indication of faults or malfunctions that are present at that moment in the sensor or Front End electronics systems. Input registers 7005/7006 hold a stored history of which these error flags have been set since the last "Reset" command, which can be used to monitor and record the occurrence transient error conditions. (See Output Coil Number 1008 on page 39 for details of how to reset the stored Error Flags).

Bit	Error Flag Designation	
0	<i>Name :</i>	ROM Error
CT	<i>Cause :</i>	Internal integrity checking by the MFC010 processor has detected a corruption of the main program code memory. Such an error could lead to a serious malfunction of the MFC010.
	<i>Action :</i>	Switch off the MFC010 immediately, do not re-use this unit until the problem is resolved. Call a service support engineer.
1	<i>Name :</i>	RAM Error
CT	<i>Cause :</i>	Internal integrity checking by the MFC010 processor has detected a corruption of the main program data memory. Such an error could lead to a serious malfunction of the MFC010.
	<i>Action :</i>	Switch off the MFC010 immediately, do not re-use this unit until the problem is resolved. Call a service support engineer.
2	<i>Name :</i>	EEPROM Write Error
CT	<i>Cause :</i>	The MFC010 processor is having problems saving configuration data to the onboard non-volatile memory.
	<i>Action :</i>	The unit can continue to be used until a service support engineer is able to attend, as long as no further configuration changes are required. See Section 8.6 on page 77 for details of saving the configuration to the non-volatile memory.
3	<i>Name :</i>	EEPROM Data Corrupted
CT	<i>Cause :</i>	The configuration settings stored in the non-volatile EEPROM memory have been corrupted, the default values have been restored to prevent a unit malfunction due to invalid settings.
	<i>Action :</i>	Re-check all of the configuration settings and if necessary reset to previous values. If this error is repeated persistently, call a service support engineer.

Bit	Error Flag Designation
4	<p><i>Name :</i> PCB Temperature</p> <p>CT <i>Cause :</i> The temperature detected on the main circuit board of the MFC010 is exceeding the maximum limit specified for the electronic components fitted to it.</p> <p><i>Action :</i> This error may be due to a component malfunction on the main MFC010 circuit board, incorrect wiring or excessive process temperatures.</p> <p>Check that the process temperature is within the specified limits of the sensor being used. The temperature history, held in Input register No. 1004 (see section 7.4 on page 43 for details), will indicate the maximum process temperature that has been measured.</p> <p>Check that the system is correctly connected, excessive power input to the MFC010 could lead to increased heat build up and subsequent component failure.</p> <p>If none of the other causes above can be attributed to be the source of the error, call a service support engineer for further guidance.</p>
5	<p><i>Name :</i> Internal Voltage Levels</p> <p>CT <i>Cause :</i> The Voltage levels within the main measurement circuits are outside of normal operating limits.</p> <p><i>Action :</i> No field maintenance can be performed to rectify this problem, the MFC010 should be replaced immediately. Call a service support engineer.</p>
6	<p><i>Name :</i> Temperature Sensor Short Circuit</p> <p>CT <i>Cause :</i> The measurement system has detected an electrical short circuit between its temperature input terminals, therefore temperature measurement is not possible. The system will default to a static temperature reading of -200°C when this error occurs, however, internally it will use the calibration reference temperature for measurement calculation to prevent sudden massive variation in the mass flow or density measurements.</p> <p><i>Action :</i> Check for short circuits between the Temperature sensor connections on the back plane circuit board and between the temperature sensor connection and the sensor case. Call a service support engineer for further advice.</p>
7	<p><i>Name :</i> Temperature Sensor Open Circuit</p> <p>CT <i>Cause :</i> The measurement system has detected an electrical open circuit between its temperature input terminals, therefore temperature measurement is not possible. The system will default to a static temperature reading of +500°C when this error occurs, however, internally it will use the calibration reference temperature for measurement calculation to prevent sudden massive variation in the mass flow or density measurements.</p> <p><i>Action :</i> Call a service support engineer</p>
8	<p><i>Name :</i> MT Strain Gauge Short Circuit</p> <p>CT <i>Cause :</i> The measurement system has detected an electrical short circuit between its measuring tube strain gauge input terminals, therefore strain measurement is not possible. The system will default to a static strain reading of 0Ω when this error occurs, however, internally it will use the calibration reference strain for measurement calculation to prevent sudden massive variation in the mass flow or density measurements.</p> <p><i>Action :</i> Call a service support engineer</p>



Bit	Error Flag Designation
9	Name : MT Strain Gauge Open Circuit
CT	Cause : The measurement system has detected an electrical open circuit between its measuring tube strain gauge input terminals, therefore strain measurement is not possible. The system will default to a static strain reading of 1000Ω when this error occurs, however, internally it will use the calibration reference strain for measurement calculation to prevent sudden massive variation in the mass flow or density measurements.
	Action : Call a service support engineer
10	Name : IC Strain Gauge Short Circuit
CT	Cause : The measurement system has detected an electrical short circuit between its inner cylinder strain gauge input terminals, therefore strain measurement is not possible. The system will default to a static strain reading of 0Ω when this error occurs, however, internally it will use the calibration reference strain for measurement calculation to prevent sudden massive variation in the mass flow or density measurements.
	Action : Call service support engineer
11	Name : IC Strain Gauge Open Circuit
CT	Cause : The measurement system has detected an electrical open circuit between its inner cylinder strain gauge input terminals, therefore strain measurement is not possible. The system will default to a static strain reading of 1000Ω when this error occurs, however, internally it will use the calibration reference strain for measurement calculation to prevent sudden massive variation in the mass flow or density measurements.
	Action : Call service support engineer
12	Name : Sensor A
CT	Cause : The measured level of Sensor A is below 5% of the required value. This error can occur for short periods following rapid changes of product density, such as when the tube changes to or from an empty state or when excessive Air bubbles are present in the product.
	Action : If this Error is persistently reported during normal operation call your service support engineer for further advice.
13	Name : Sensor B
CT	Cause : The measured level of Sensor B is below 5% of the required value. This error can occur for short periods following rapid changes of product density, such as when the tube changes to or from an empty state or when excessive Air bubbles are present in the product.
	Action : If this Error is persistently reported during normal operation call your service support engineer for further advice.
14	Name : Ratio A/B
CT	Cause : The ratio of the two sensor signals is too large, i.e. one of the motion sensors is giving a reading significantly below the other sufficient to cause an error in the mass flow calculations. This may be caused by or the cause of instability in the tube oscillation control system.
	Action : Call service support engineer
15	Name : DC A
CT	Cause : The DC component of the motion Sensor A signal is too large.
	Action : Call service support engineer.
16	Name : DC B
CT	Cause : The DC component of the motion Sensor B signal is too large.
	Action : Call service support engineer.

Bit	Error Flag Designation	
17	<i>Name :</i>	Drive System Open Circuit
	<i>Cause :</i>	The tube oscillation control system has detected an open circuit in the connection the to tube drive coil.
	<i>Action :</i>	Call service support engineer.
18	<i>Name :</i>	Drive System Short Circuit
	<i>Cause :</i>	The tube oscillation control system has detected an short circuit in the connection to the tube drive coil.
	<i>Action :</i>	Call service support engineer.
19	<i>Name :</i>	Front End Amplifier Failure
	<i>Cause :</i>	The measurement system has detected a failure in the motion sensor interface circuit.
	<i>Action :</i>	Switch off the unit immediately to prevent damage to the sensor. This cannot be repaired in the field, the Front End electronics must be replaced. Call a service support engineer.
20	<i>Name :</i>	Harmonic Distortion of Sensor A
	<i>Cause :</i>	Not Currently Implemented
	<i>Action :</i>	Call service support engineer
21	<i>Name :</i>	Harmonic Distortion of Sensor B
	<i>Cause :</i>	Not Currently Implemented
	<i>Action :</i>	Call service support engineer
22	<i>Name :</i>	Watchdog Reset Event
	<i>Cause :</i>	Not Currently Implemented
	<i>Action :</i>	Call service support engineer
23	<i>Name :</i>	<i>Reserved for Future Use</i>
24	<i>Name :</i>	<i>Reserved for Future Use</i>
25	<i>Name :</i>	<i>Reserved for Future Use</i>
26	<i>Name :</i>	<i>Reserved for Future Use</i>
27	<i>Name :</i>	<i>Reserved for Future Use</i>
28	<i>Name :</i>	<i>Reserved for Future Use</i>
29	<i>Name :</i>	<i>Reserved for Future Use</i>
30	<i>Name :</i>	<i>Reserved for Future Use</i>
31	<i>Name :</i>	<i>Reserved for Future Use</i>

9.2 Process Warnings

The Process Warning flags, held as a long integer value in input registers 7003/7004, are an indication of process conditions that are present at that moment that may adversely affect the measurement operation or accuracy of the mass flow sensor, such as exceeding the specified operating limits of the sensor. Input registers 7007/7008 hold a stored history of which these warning flags have been set since the last "Reset" command, which can be used to monitor and record the occurrence of transient process warning conditions. (See Output Coil Number 1009 on page 39 for details of how to reset the stored Error Flags).

Bit	Warning Flag Designation	
0	<i>Name :</i>	Mass Flow Over-range
CT	<i>Cause :</i>	The measured mass flow is beyond the maximum allowable limit for this sensor
1	<i>Name :</i>	Process Temperature Outside Limits
CT	<i>Cause :</i>	The measured tube temperature has been outside of the permissible operating limits of the sensor.
2	<i>Name :</i>	Process Density Over-range
CT	<i>Cause :</i>	The product density is beyond the allowable limits of the system to enable accurate measurement
3	<i>Name :</i>	Mass Totaliser Over-flow
CT	<i>Cause :</i>	The Mass total value has overflowed, i.e. the mass total variable has previously reached its maximum permissible value and therefore has been forced to return to zero after the following increment.
4	<i>Name :</i>	Volume Totaliser Over-flow
CT	<i>Cause :</i>	The Volume total value has overflowed, i.e. the Volume total variable has previously reached its maximum permissible value and therefore has been forced to return to zero after the following increment.
5	<i>Name :</i>	Additional Totaliser Over-flow
	<i>Cause :</i>	The Additional total value has overflowed, i.e. the Additional total variable has previously reached its maximum permissible value and therefore has been forced to return to zero after the following increment.
6	<i>Name :</i>	Concentration By Mass Totaliser Over-flow
	<i>Cause :</i>	The Concentration Total - By Mass value has overflowed, i.e. the Concentration Mass total variable has previously reached its maximum permissible value and therefore has been forced to return to zero after the following increment.
7	<i>Name :</i>	Concentration By Volume Totaliser Over-flow
	<i>Cause :</i>	The Concentration Total – By Volume value has overflowed, i.e. the Concentration Volume total variable has previously reached its maximum permissible value and therefore has been forced to return to zero after the following increment.

Bit	Warning Flag Designation
8	<i>Name :</i> Zero Flow Calibration Above Limits <i>Cause :</i> The Mass flow rate during the previous Mass flow zero calibration attempt was above 10% of the nominal flow or this sensor.
9	<i>Name :</i> Zero Flow Calibration Failed <i>Cause :</i> The previous Mass flow zero calibration failed. Refer to section 8.1 on page 71 for further details.
10	<i>Name :</i> Temperature Drift  <i>Cause :</i> The measured temperature has exceeded $\pm 30^{\circ}\text{C}$ from the temperature reference taken during the last Mass Flow zero calibration. For use in Custody transfer applications.
11	<i>Name :</i> Power Fail  <i>Cause :</i> This flag is set when the system is started to indicate that the power supply has been interrupted.
12	<i>Name :</i> Sampling  <i>Cause :</i> The tube oscillation control system has had difficulty locking onto the tube drive frequency, which may have resulted in inaccurate measurement values.
13	<i>Name :</i> 2 Phase Signal Above Limit <i>Cause :</i> 2 phase signal is above the threshold limit set
14	<i>Name :</i> Tube Asymmetry <i>Cause :</i> Not Currently Implemented
15	<i>Name :</i> External Vibration <i>Cause :</i> Not Currently Implemented
16	<i>Name :</i> Pulsating Flow <i>Cause :</i> Not Currently Implemented
17	<i>Name :</i> Partially Empty System <i>Cause :</i> Not Currently Implemented
18	<i>Name :</i> <i>Reserved for Future Use</i>
19	<i>Name :</i> <i>Reserved for Future Use</i>
20	<i>Name :</i> <i>Reserved for Future Use</i>
21	<i>Name :</i> <i>Reserved for Future Use</i>
22	<i>Name :</i> <i>Reserved for Future Use</i>
23	<i>Name :</i> <i>Reserved for Future Use</i>
24	<i>Name :</i> <i>Reserved for Future Use</i>
25	<i>Name :</i> <i>Reserved for Future Use</i>

Bit	Warning Flag Designation
26	Name : <i>Reserved for Future Use</i>
27	Name : <i>Reserved for Future Use</i>
28	Name : <i>Reserved for Future Use</i>
29	Name : <i>Reserved for Future Use</i>
30	Name : <i>Reserved for Future Use</i>
31	Name : <i>Reserved for Future Use</i>

10. Trouble Shooting

The following are some examples of common problems caused by incorrect installation or operation of the MFC010. Check these before contacting service support.

10.1 “No Response to Modbus Requests”

There are a number of possibilities as to why no response would be received from the MFC010. Here is a list of some of the more obvious things to check.

- a) Check is that there is an appropriate voltage input on the V+ and V- terminals of the MFC010. (See section 3.1 on page 6 for the power input parameters).
- b) Ensure that there is continuity between the A and B input terminals and their associated terminals at the master control device. Check that A and B are connected correctly as indicated in section 3.3. Ensure that there is a proper “Common” connection between the master device and the MFC010. When used in Hazardous areas the in-line resistance and capacitance of any barrier devices may prevent communication if not specified and installed properly (Refer to section 4 for further details).
- c) The MFC010 will ignore messages that are not addressed to it, or any message that contains fundamental formatting errors. So, check that the Address ID that is being requested is correct, the default value is 1. Check that the transmission rate (default = 19200 Baud) and format (default = 8 data bits, Even parity and 1 stop bit) are correct. (See section 5 on page 19 for the transmission format details).

10.2 “Communication Errors”

Intermittent communication errors can have a number of causes, almost all of which can be attributed to the quality of the connection between the Master device and the MFC010, such as

- a) Low quality connections at the terminals of the MFC010 or Master Device, ensure that good contact is being made and that the connections are not frayed or corroded.
- b) Cable lengths and/or cable capacitance are too great for the data rates being used.
- c) Powerful sources of electromagnetic interference in close proximity to the path of the cable route, refer to the installation guidelines in section 3.5 on page 12.
- d) It is common to use converter devices to connect the Modbus RS485 output of the MFC010 to the serial RS232 port or USB port of a host PC using off-the-shelf protocol converters. Many of these, especially USB based converters will have problems operating the Modbus Interface as it is a timing critical protocol. Where possible, a dedicated RS485 interface PC card should be used.

10.3 “The MFC010 is responding with an Illegal Modbus Function Message”

There can be two reasons why this error response will be returned by the MFC010 in answer to a request.

- a) The Function being requested is not valid for the MFC010, check the list of valid Modbus functions in section 6 on page 23.
- b) An attempt is being made to write to a password protected holding register. The password must be de-activated before an attempt to write to the register is made. All registers are protected by the Supervisor password when it is active. Those registers that are protected by the Service or Custody Transfer passwords are indicated in the relevant sections of this document, see section 7.1 on page 33 for a summary. See section 8.5 on page 76 and section 8.9 on page 78 for further details on the operation of the passwords.

10.4 “The MFC010 is responding with an Illegal Data Message”

When the MFC010 responds with an “Illegal data message”, it is because the value being written to a holding register in the MFC010 is beyond the permitted limits for that register, the limits for each holding register are indicated in section 7.5.

10.5 “The MFC010 is responding with an Illegal Address Message”

There are four reasons why the MFC010 will return an “Illegal Address” error message when the Master device makes a request.

- a) The register address being requested is not supported by the MFC010, check the requested register against the register summary in section 7.1.
- b) Although the Start address is valid, when accessing multiple registers the number of registers requested may extend beyond the end of the valid address range for that group of variables. Check the number of variables requested and ensure that the last register address is valid.
- c) The number of registers requested is not correct for the data type being requested. For example, if registers containing floating point variables are requested then the number of requested registers must be a multiple of 2 as the floating point variables are held in two consecutive registers. For Double precision floating point variables the number of registers requested must be a multiple of 4.
- d) From “c” above, the system will respond with an “Invalid Address” error when an attempt is made to access the associated registers of a multi-register variable, for example when access to the second register of a floating point variable is attempted. i.e. if an attempt is made to access Input register 3002, which contains the second half of the variable accessed by Input register 3001.

Appendix A : Modbus CRC Checksum Calculation

The Procedure for calculating the CRC checksum for a Modbus Telegram is as follows (copyright Modbus-IDA).

1. Load a 16-bit register with $FFFF_{16}$. This is the CRC register
2. Exclusive OR the first byte of the telegram with the low-order byte of the CRC, placing the result in the CRC register
3. Shift the CRC register one bit to the right (toward the LSB), zero-filling the MSB. Extract and examine the LSB.
4. If the LSB of the CRC result was 0 : Repeat Step 3 (another shift)
If the LSB of the CRC result was 1 : Exclusive OR the CRC register with the polynomial value $A001_{16}$ ($1010\ 0000\ 0000\ 0001_2$).
5. Repeat steps 3 and 4 until 8 shifts have been performed. When this is done, a complete 8-bit byte will have been processed.
6. Repeat steps 2 through 5 for the next 8 bit character of the message. Continue doing this until all of the characters in the message have been processed.
7. The final resulting value held in the CRC register is the CRC Checksum value.

The result is a 16 bit "Unsigned Integer". The Least Significant byte of the checksum result is placed in the first of the telegram CRC characters, the Most significant byte is placed in the second of the telegram CRC characters, the overall last character in the telegram. See Section 3.1 for the telegram format details. Refer to the Modbus Protocol Reference Guide for more details on calculating the telegram CRC value.

The following routine, written in the 'C' programming language, demonstrates the method for calculating the checksum.

```

unsigned short Calculate_Checksum (unsigned char uc_Telegram_Length, unsigned short *Buffer_Pointer )
{
    // Declare Local Variables
    unsigned char uc_Byte_Loop;
    unsigned char uc_Bit_Loop;
    unsigned short us_Temporary_Checksum;
    // Initialise the checksum value
    unsigned short us_Checksum = 0xFFFF;

    // Loop through each byte of the telegram Buffer
    for (uc_Byte_Loop = 0; uc_Byte_Loop < uc_Telegram_Length; uc_Byte_Loop++)
    {
        // XOR the newly indexed buffer location with the current value of the checksum
        us_Checksum ^= *(Buffer_Pointer + uc_Byte_Loop) & 0x00FF;
        // Perform an 8 bit rotation and Polynomial addition on the checksum
        for(uc_Bit_Loop = 0; uc_Bit_Loop < 8; uc_Bit_Loop++)
        {
            // Store the current value of the checksum in a temporary local variable
            us_Temporary_Checksum = us_Checksum;
            // Right shift the Checksum by one bit
            us_Checksum >>= 1;
            // Was the first bit of the checksum set?
            if (us_Temporary_Checksum & 0x0001)
            {
                // If so, XOR the Checksum with the Polynomial value
                us_Checksum ^= 0xA001;
            }
        }
    }
    // Return the calculated checksum result
    return us_Checksum;
}

```

Appendix B : Hexadecimal and Binary Notation

The Binary (Base 2) and Hexadecimal (Base 16) mathematical notations are more commonly used in computer systems because they can be used to more easily represent the digital values involved. Within this document Binary numbers are indicated by a subscript “2” appended the number, e.g. 10101_2 , and Hexadecimal numbers are indicated by a subscript “16” appended to the number, e.g. $E45F_{16}$.

Where decimal numbers are represented using the digits 0 to 9, binary numbers are represented using the digits 0 to 1, and hexadecimal numbers are represented using the digits 0 to 9 and A to F. i.e.

Decimal	Binary ₂	Hexadecimal ₁₆
0	0000	0
1	0001	1
2	0010	2
3	0011	3
4	0100	4
5	0101	5
6	0110	6
7	0111	7
8	1000	8
9	1001	9
10	1010	A
11	1011	B
12	1100	C
13	1101	D
14	1110	E
15	1111	F

As with decimal numbers, the most significant, MS, digit of a Binary or Hexadecimal number is on the left of the number and the least significant, LS, digit is on the right. e.g. for the decimal number 34567, the MS digit is 3 and the LS Digit is 7.

The standard data representation within computer systems is the “Byte” which consists of 8 binary digits, or “bits”. Each byte, being 8 bits long can easily be represented as two Hexadecimal digits.

e.g. F_{16} Hexadecimal = $1111\ 1111_2$ Binary = 255 Decimal
 $3A_{16}$ Hexadecimal = $0011\ 1010_2$ Binary = 58 Decimal

The “Bits” of a byte are indexed from the LS bit, which is bit 0 up to the MS bit which is bit 7. Each bit represents a value of 2^{index} , such that bit 7 represents $2^7 = 128$, and bit 3 represents $2^3 = 8$ and so on. So an 8 bit binary value of 00110010_2 is equal to a decimal value of $2^1 + 2^4 + 2^5 = 2 + 16 + 32 = 50$. With all of the bits of an 8 bit binary value set, the result will be $2^8 - 1 = 255$ ($2^0 + 2^1 + 2^2 + 2^3 + 2^4 + 2^5 + 2^6 + 2^7 = 1 + 2 + 4 + 8 + 16 + 32 + 64 + 128 = 255$).

When representing numbers within a computer system, multiple bytes are used to form values up to 16, 32 and 64 bits long. This allows the computer system to represent whole numbers up to $2^{64} - 1$. For the representation of larger numbers and fractions, the computer system will use “Floating Point” representations, see Appendix C for further details.

When transmitting and receiving data in a serial format as with the Modbus protocol it is important to understand in which order the register values are transmitted. The Modbus registers are 16 bits long and can therefore represent integer values up to $2^{16} - 1 = 65535$. The registers are transmitted as two bytes, also known as characters, with the most significant byte being transmitted before the least significant byte. The least significant byte contains the 8 least significant bits, i.e. bits 0 to 7, while the most significant byte contains the 8 most significant bits, i.e. bits 8 to 15 in a 16 bit value. Each byte is transmitted in order from its most significant bit down to its least significant bit.

Appendix C : Decoding Floating Point Numbers

Floating point numbers in computer systems are used to represent values over a larger range than is practical with standard integers. The representation of the value is achieved by splitting it into three parts, the sign “S” (±), the Exponent “E” and the Mantissa or Fraction “M”.

Single Precision Floating Point Numbers (“Floats”)

Single precision floating-point values are coded in a group of 4 bytes (32 bits, as shown below). This enables the computer to represent values over a range of $\pm 3.4 \times 10^{\pm 38}$, with an accuracy of 7 decimal digits.

S	E	E	E	E	E	E	E	E	M	M	M	M	M	M	M	M	M	M	M	M	M	M	M	M	M	M	M	M	M	M	M	M	M
Byte 3 (MSB)								Byte 2								Byte 1								Byte 0 (LSB)									

To encode a value into a floating-point representation, use the following process.

Step 1 : If Value < 0 (i.e. negative) S = 1, otherwise S = 0

Step 2 : Set E = 127

Step 3 : If Value < 2, skip to step 6

Step 4 : Divide the Value by 2, add 1 to E

Step 5 : Go back to step 3

Step 6 : If Value > 1, skip to step 9

Step 7 : Multiply the Value by 2, subtract 1 from E

Step 8 : Go back to step 6

Step 9 : $M = (\text{Value} - 1) * 2^{23}$

For Example :

Value = 206171.125

Step 1 : Value > 0, so S = 0

Step 2 : E = 127

Step 3 – Step 6, Divide value by 2, 17 times, $E = 127 + 17 = 144 = 90_{16}$
 $\text{Value} = 206171.125 / 2^{17} = 1.5729609$

Step 9 : $M = (1.5729609 - 1) * 2^{23} = 4806344 = 4956C8_{16}$

Therefore the result is 0100 1000 0100 1001 0101 0110 1100 1000 = 484956C8₁₆

To decode a floating point representation use the following formula.

$$\text{Floating Point Value} = -1^S \times 2^{(E-127)} \times [1 + \{ M / 2^{23} \}]$$

Working backwards from the previous example :

Floating point Number 484956C8₁₆ = 0100 1000 0100 1001 0101 0110 1100 1000₂

So..... S = 0
 E = 100 1000 0 = 90₁₆ = 144

Appendix D : Sensor Sizes and Associated Default Register Settings

The available ranges and default settings of a number of the Holding registers (see section 7.5) depend upon the sensor settings stored in Holding registers 1012, 1013 and 1014. The following table provides a summary of these inter-related values. Whenever any of the three sensor settings are changed, the associated defaults will be loaded. The Size setting will be set to its default value if the Sensor type is changed, the Material setting will only be changed if the new sensor type does not support the current Material setting.

NB. CAUTION, Changing the Sensor settings will overwrite the factory calibration coefficients CF1 to CF27 and the operational configuration.

Sensor			Defaults					
Type	Size	Material	CF5	Pipe Diameter	Tube Amplitude	Maximum Temperature	Minimum Temperature	
1012	1013	1014	3009	3043	1015	3097	3099	
7000	06	Titanium	5500	5.53 mm	80%	+150 °C	- 40 °C	
		Hastelloy	5000	6.00 mm	80%	+100 °C	0 °C	
		Stainless Steel	15000	5.53 mm	80%	+100 °C	0 °C	
	10	Titanium	15000	8.56 mm	80%	+150 °C	- 40 °C	
		Hastelloy	37000	8.46 mm	80%	+100 °C	0 °C	
		Stainless Steel	28000	8.40 mm	80%	+100 °C	0 °C	
	15	Titanium	75000	14.80 mm	80%	+150 °C	- 40 °C	
		Hastelloy	150000	14.96 mm	80%	+100 °C	0 °C	
		Stainless Steel	120000	14.96 mm	80%	+100 °C	0 °C	
	25	Titanium	160000	23.98 mm	80%	+150 °C	- 40 °C	
		Hastelloy	330000	24.28 mm	80%	+100 °C	0 °C	
		Stainless Steel	290000	24.28 mm	80%	+100 °C	0 °C	
	40	Titanium	330000	36.28 mm	80%	+150 °C	- 40 °C	
		Hastelloy	640000	36.68 mm	80%	+100 °C	0 °C	
		Stainless Steel	600000	36.68 mm	80%	+100 °C	0 °C	
	50	Titanium	550000	48.32 mm	60%	+150 °C	- 40 °C	
		Hastelloy	1000000	48.80 mm	60%	+100 °C	0 °C	
		Stainless Steel	800000	46.26 mm	60%	+100 °C	0 °C	
	80	Titanium	1300000	68.80 mm	60%	+150 °C	- 40 °C	
		Hastelloy	2000000	70.23 mm	60%	+100 °C	0 °C	
		Stainless Steel	1700000	70.23 mm	60%	+100 °C	0 °C	
	3000	01	Hastelloy	17	1.20 mm	55%	+150 °C	- 40 °C
			Stainless Steel	17	1.20 mm	55%	+150 °C	- 40 °C
		03	Hastelloy	100	2.58 mm	55%	+150 °C	- 40 °C
			Stainless Steel	100	2.58 mm	55%	+150 °C	- 40 °C
		04	Hastelloy	300	3.94 mm	55%	+150 °C	- 40 °C
			Stainless Steel	300	3.94 mm	55%	+150 °C	- 40 °C
5000	15	Stainless Steel	8500	15.00 mm	80%	+93 °C	- 40 °C	
	25	Stainless Steel	14200	25.00 mm	80%	+93 °C	- 40 °C	

8000	15	Titanium	12000	10.7 mm	80%	+200 °C	- 10 °C	
		Hastelloy	12000	10.7 mm	80%	+230 °C	- 180 °C	
		Stainless Steel	12000	10.7 mm	80%	+230 °C	- 180 °C	
	25	Titanium	43500	18.9 mm	80%	+200 °C	- 10 °C	
		Hastelloy	43500	18.9 mm	80%	+230 °C	- 180 °C	
		Stainless Steel	43500	18.9 mm	80%	+230 °C	- 180 °C	
	40	Titanium	200000	31.2 mm	80%	+200 °C	- 10 °C	
		Hastelloy	200000	31.2 mm	80%	+230 °C	- 180 °C	
		Stainless Steel	200000	31.2 mm	80%	+230 °C	- 180 °C	
	80	Titanium	300000	52.6 mm	80%	+200 °C	- 10 °C	
		Hastelloy	300000	52.6 mm	80%	+230 °C	- 180 °C	
		Stainless Steel	300000	52.6 mm	80%	+230 °C	- 180 °C	
100	Titanium	650000	77.9 mm	80%	+200 °C	- 10 °C		
	Hastelloy	650000	77.9 mm	80%	+230 °C	- 180 °C		
	Stainless Steel	650000	77.9 mm	80%	+230 °C	- 180 °C		
9000	15	Hastelloy	12000	10.7 mm	80%	+350 °C	-0 °C	
		Stainless Steel	12000	10.7 mm	80%	+350 °C	-0 °C	
	25	Hastelloy	43500	18.9 mm	80%	+350 °C	-0 °C	
		Stainless Steel	43500	18.9 mm	80%	+350 °C	-0 °C	
	40	Hastelloy	200000	31.2 mm	80%	+350 °C	-0 °C	
		Stainless Steel	200000	31.2 mm	80%	+350 °C	-0 °C	
	80	Hastelloy	300000	52.6 mm	80%	+350 °C	-0 °C	
		Stainless Steel	300000	52.6 mm	80%	+350 °C	-0 °C	
	100	Hastelloy	650000	77.9 mm	80%	+350 °C	-0 °C	
		Stainless Steel	650000	77.9 mm	80%	+350 °C	-0 °C	
	1000	15	Stainless Steel	78600	12.3mm	80%	+130 °C	- 40 °C
		25	Stainless Steel	202000	21.16mm	80%	+130 °C	- 40 °C
40		Stainless Steel	456000	34.34mm	80%	+130 °C	- 40 °C	
50		Stainless Steel	1140000	51.87mm	80%	+130 °C	- 40 °C	

Application Note

Connection of Power supplies in MFC010 Applications

The MFC010 is a self contained Mass flow measurement converter which requires an external 12V DC input supply. In many applications, a dedicated off the shelf power supply will be used. In these cases careful note should be made to the EMC compliance of the power supply chosen. Many off the shelf power supplies are certified to Class B compliance, where temporary degradation of performance is permitted when Electromagnetic Interference is present. However, degradation in the performance of the power supply may have an undue influence on the operation or performance of the MFC010.

To maintain MFC010 operation within specification it is advised to comply with the following suggestions when installing EMC Class B certified power supplies.

- i) ALWAYS install the power supply in a properly Earthed METAL enclosure
- ii) Connect suitable Y Class suppression capacitors (such as the Vishay WKP or WKO type) from each power supply input terminal to a robust Earth connection.
- iii) Connect a suitable Y Class suppression capacitor (such as the Vishay WKP or WKO type) between the 12V output terminals of the power supply.
- iv) Fit a suitable ferrite (such as a 74271132 from Würth Elektronik) to the cable immediately after the power supply output terminals.

All of the capacitors should be fitted in as close proximity to the Power supply terminals as is possible, ideally at the terminals themselves.

The two types of power supply available from KROHNE, 85-265VAC input and 20-72 VDC input, are supplied with the recommended suppression capacitors. The MFC010 has been tested and certified for EMC compliance using these power supplies in association with the supplied capacitors. The following pages indicate the actual terminals of each power supply to which these capacitors should be fitted.

Power supplies that conform to Class A operation should not require further EMC suppression components, but should be housed in a suitable enclosure. Care must always be taken when installing such complex electrical systems as poor installation can lead to degraded system performance, regardless of how well designed and certified the individual components are.

LOS4301-2 : 85V - 265V AC Input

When using the LOS4301-2 power supply, it is recommended to use three 470pF/400VAC (Vishay Part No. WKP471MCPEFOK) capacitors. These are included with the power supply when it is ordered from KROHNE. The capacitors should be connected as follows.

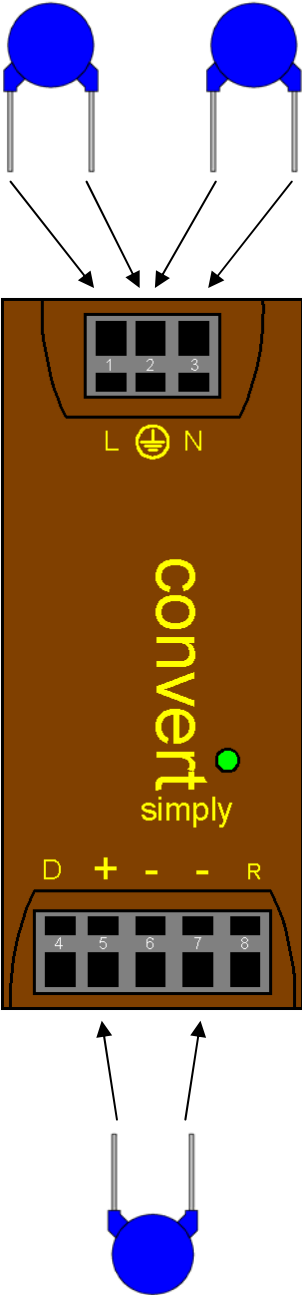

SCD30 S12 - DN : 20 - 72V DC Input

When using the SCD30 S12-DN power supply, it is recommended to use three 3.3nF/400VAC (Vishay Part No. WKO332MCPCJOK) capacitors. These are included with the power supply when it is ordered from KROHNE. The capacitors should be connected as follows.

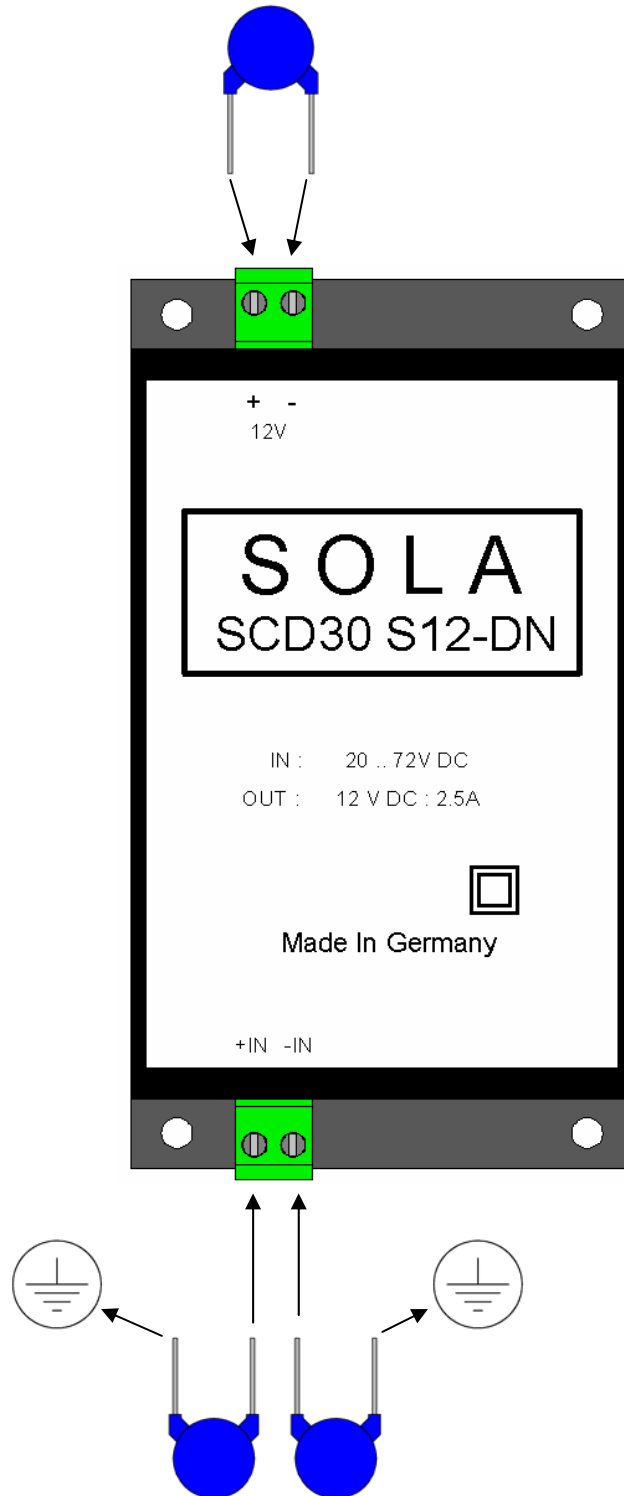

MFC010 Toolbox is a configuration, diagnostics and evaluation tool for the Krohne OPTIMASS and OPTIGAS flow sensors fitted with the MFC010 Sensor Electronics. The complete Graphical User Interface provides measurement display, diagnostics information and real time data logging. Use MFC010 Toolbox to quickly and easily configure your OPTIMASS and OPTIGAS flow sensors for any OEM application and save your register setup to a file for downloading to several units.

MFC010 Toolbox software is provided with every order including the MFC010 Sensor Electronics.

MFC010 Toolbox also requires:

- An OPTIMASS or OPTIGAS flow sensor with the MFC010 Sensor Electronics (software version: 2.11 or above);
- The .NET Framework version 2.0 (can be downloaded during installation);
- A compatible Serial Port or USB to Serial Port Adaptor;
- An RS232 to RS485 Converter;
- An approved Power Supply and required Barrier modules.

Please refer to the help files when connecting the meter to your PC for the first time & for detailed instructions on using MFC010 Toolbox.

Features of the MFC010 Toolbox include:

- Easy connection using AutoConnect feature (suitable for point-to-point communication only)
- Easy configuration of all necessary operating parameters using text boxes and drop-down menus
- Loading/Saving the configuration data from/to a file
- Data Logger tool allowing the user to record and view measurement data for real time trend analysis & gain a better understanding of their process and diagnose application problems
- Modbus Terminal window provides a telegram editor where users can construct and send Modbus telegrams for test purposes

Notes Page:

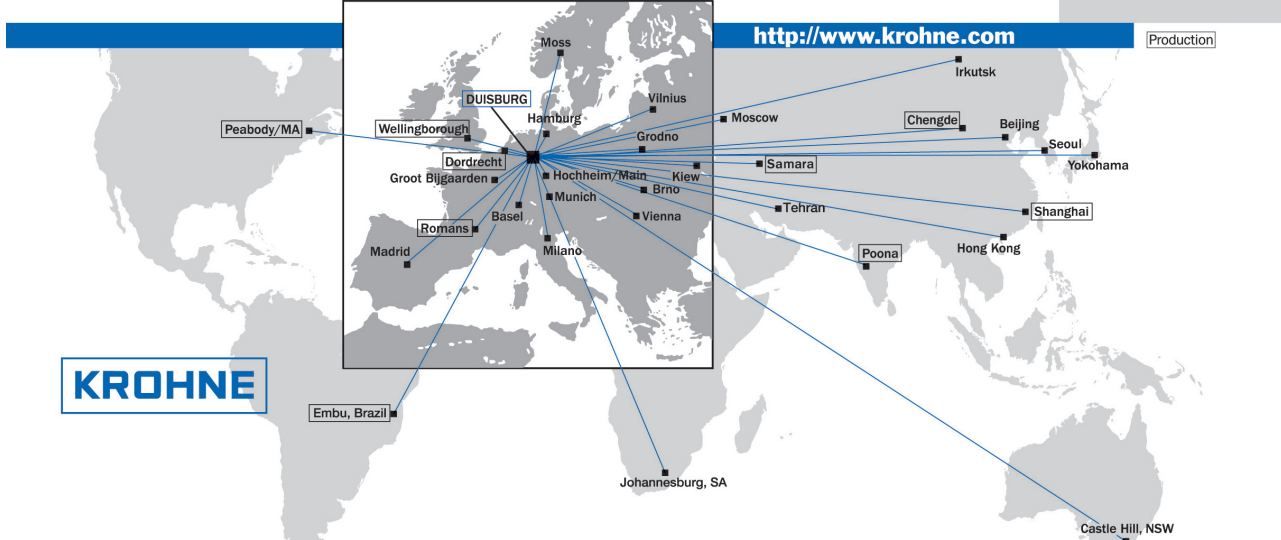

KROHNE

<http://www.krohne.com>

Production

Australia

KROHNE Australia Pty Ltd
Quantum Business Park
10/287 Victoria Rd
Rydalmere NSW 2116
TEL: +61 2 8846 1700
FAX: +61 2 8846 1755
e-mail: krohne@krohne.com.au

Austria

KROHNE Austria Ges.m.b.H.
Modecenterstraße 14
A-1030 Wien
TEL: +43(0)1/203 45 32
FAX: +43(0)1/203 47 78
e-mail: info@krohne.at

Belgium

KROHNE Belgium N.V.
Brusselstraat 320
B-1702 Groot Bijgaarden
TEL: +32(0)2-4 66 00 10
FAX: +32(0)2-4 66 08 00
e-mail: krohne@krohne.be

Brazil

KROHNE Conaut
Controles Automaticos Ltda.
Estrada Louis Pasteur, 230 C.P. 56
06835 - 080 EMBU - SP
TEL: +55(0)11-4785-2700
FAX: +55(0)11-4785-2768
e-mail: conaut@conaut.com.br

China

KROHNE Measurement Instruments
(Shanghai) Co. Ltd.
9th Floor, Xujiahui International Building
1033 Zhaojabang Road
Shanghai 200030
P.R. China
TEL: +86 21 6487 9611
FAX: +86 21 6438 7110
e-mail: info@krohne-asia.com

CIS

Kanex KROHNE Engineering AG
Business-Centre Planeta, Office 403
Manistskaja-Street 3
109147 Moscow/Russia
TEL: +7(0)095-9117 165
FAX: +7(0)095-9117 231
e-mail: krohne@dol.ru

Czech Republic

KROHNE CZ, spol. s r.o.
Soběšická 156
63800 Brno
TEL: +420 545 532 111
FAX: +420 545 220 093
e-mail: bmo@krohne.cz

France

KROHNE S.A.S.
Les Ours
BP 98
F-26103 ROMANS Cedex
TEL: +33(0)4-75 05 44 00
FAX: +33(0)4-75 05 00 48
e-mail: info@krohne.fr

Germany

KROHNE Messtechnik
GmbH & Co. KG
Ludwig-Krohne-Str.
D-47058 Duisburg
TEL: +49(0)203-301-0
FAX: +49(0)203-301-10 389
e-mail: info@krohne.de

India

KROHNE Marshall Ltd.
A-34/35, M.I.D.C.
Industrial Area, H-Block,
Pimpri Poona 411018
TEL: +91(0)202-7442020
FAX: +91(0)202-7442020
e-mail: pcu@vsnl.net

Iran

KROHNE Liaison Office
North Soltreivandi Ave.
26, Samad St., Apt. #9
Tehran 15539
TEL: +98-21-874-5973
FAX: +98-21-850-1268
e-mail: krohne@krohneiran.com

Italy

KROHNE Italia Srl.
Via V. Monti 75
I-20145 Milano
TEL: +39(0)2-4 30 06 61
FAX: +39(0)2-43 00 66 66
e-mail: info@krohne.it

Korea

KROHNE Korea
Room 508 Miwon Bldg
43 Yoido-Dong
Youngdeungpo-Ku
Seoul, Korea
TEL: 00-82-2-780-1743
FAX: 00-82-2-780-1749
e-mail: krohnekorea@krohnekorea.com

Netherlands

KROHNE Altometer
Kerkeplaat 12
NL-3313 LC Dordrecht
TEL: +31(0)78-6306300
FAX: +31(0)78-6306390
e-mail: postmaster@krohne-altometer.nl

Netherlands

KROHNE Nederland B.V.
Kerkeplaat 14
NL-3313 LC Dordrecht
TEL: +31(0)78-6306200
FAX: +31(0)78-6306405
Service Direkt: +31(0)78-6306222
e-mail: info@krohne.nl

Norway

KROHNE Norway A.S.
Ekholtheien 114
NO-1526 Moss
P.O. Box 2178, NO-1521 Moss
TEL: +47(0)69-264860
FAX: +47(0)69-267333
e-mail: postmaster@krohne.no
Internet: www.krohne.no

Singapore

Tokyo Keiso - KROHNE Singapore Pte. Ltd.
14, International Business Park,
Jurong East
Chiyoda Building #01-01/02
Singapore 609922
Singapore
TEL: +65-65-67-4548
FAX: +65-65-67-9874

South Africa

KROHNE Pty. Ltd.
163 New Road
Halfway House Ext. 13
Midrand
TEL: +27(0)11-315-2685
FAX: +27(0)11-805-0531
e-mail: midrand@krohne.co.za

Spain

I.I. KROHNE Iberia, S.r.L.
Poligono Industrial Nilo
Calle Brasil, n.º. 5
E-28806 Alcalá de Henares-Madrid
TEL: +34(0)91-8 83 21 52
FAX: +34(0)91-8 83 48 54
e-mail: krohne@krohne.es

Switzerland

KROHNE AG
Uferstr. 90
CH-4019 Basel
TEL: +41(0)61-638 30 30
FAX: +41(0)61-638 30 40
e-mail: info@krohne.ch

United Kingdom

KROHNE Ltd.
Rutherford Drive
Park Farm Industrial Estate
Wellingborough,
Northants NN9 6AE, UK
TEL: +44(0)19 33-408 500
FAX: +44(0)19 33-408 501
e-mail: info@krohne.co.uk

USA

KROHNE Inc.
7 Dearborn Road
Peabody, MA 01960
TEL: +1-978 535-6060
FAX: +1-978 535-1720
e-mail: info@krohne.com

Other Representatives

- | | |
|-------------|--------------|
| Algeria | Kuwait |
| Argentina | Libya |
| Belarus | Lithuania |
| Belgium | Malaysia |
| Canada | Morocco |
| Chile | Mauritius |
| Colombia | Mexico |
| Croatia | New Zealand |
| Denmark | Peru |
| Ecuador | Poland |
| Egypt | Portugal |
| Finland | Romania |
| Gabon | Saudi Arabia |
| Ghana | Senegal |
| Greece | Slovakia |
| Hong Kong | Slovenia |
| Hungary | Sweden |
| Indonesia | Taiwan |
| Ivory Coast | Thailand |
| Iran | Turkey |
| Ireland | Tunisia |
| Israel | Venezuela |
| Japan | Yugoslavia |
| Jordan | |

Other Countries

KROHNE Messtechnik
GmbH & Co. KG
Ludwig-Krohne-Str.
D-47058 Duisburg
TEL: +49(0)203-301-0
FAX: +49(0)203-301-389
e-mail: export@krohne.de

Subject to change without notice

Krohne reserves the right to make changes without prior notice

7.02527.23.00

© KROHNE 07/2007