

Fundamentals of Ultrasonic- flow measurement for industrial applications

Dipl.-Ing. Friedrich Hofmann

KROHNE Messtechnik GmbH & Co. KG
Duisburg, 2000

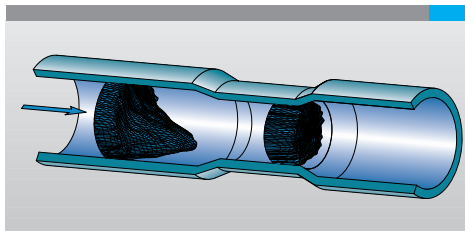

Contents

Page

1 Summary	3
2 Acoustic properties of liquids and gases	4
3 Ultrasonic Doppler flowmeters	5
The principle	5
Advantages of the ultrasonic Doppler flowmeter	6
Drawbacks and limitations of the ultrasonic Doppler flowmeter	6
Application fields for ultrasonic Doppler flow measurement	6
4 Ultrasonic flowmeters operating by the transit-time differential method, measuring principle	7
Basically quite simple	7
Measuring principle	7
5 Types of ultrasonic flowmeters operating by the transit-time differential method	11
Clamp-on flowmeters	11
In-line ultrasonic flowmeters for liquids, by the transit-time differential method	13
In-line ultrasonic flowmeters for gases, by the transit-time differential method	17
6 Weldable sensor assemblies	20
7 Ultrasonic volumetric meter ALTOSONIC V for custody transfer	21
Terms of reference	21
5 measuring paths in the ALTOSONIC V	22
Approvals, tests	24
Ultrasonic volumetric meter for custody transfer in a multi-product pipeline	24
8 Practice-proven: ultrasonic flow measurement technology	25
9 Ultrasonic flowmeters by the transit-time differential method, current limits of application	28
10 List of illustrations	29

Summary

Ultrasonic flowmeters have been used in industry for over 20 years for the volumetric flowmetering of liquids, gases and - more recently - steam. Basically, the distinction is made between two methods:

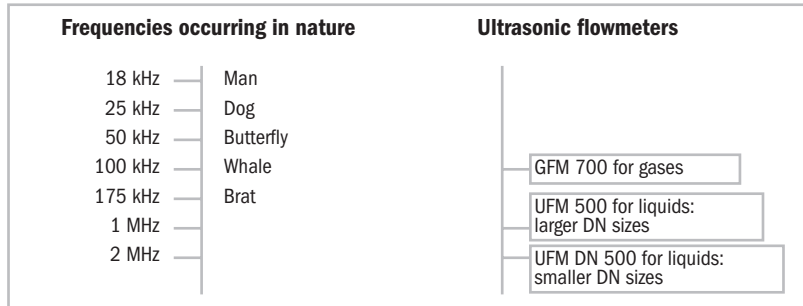

Fig. 1:
Sound frequencies
in nature and in
ultrasonic flow
measurement

The Doppler process

In order to work, this method needs reflectors in the process product. Due to malfunctioning, incorrect application and, as a result, a feeling of uncertainty, it gave ultrasonic flow measurement a bad name in the 1970s. It is now used only in a few special applications.

The transit-time differential method

This method has been working successfully in industrial applications for more than 20 years. It is accurate and reliable. Besides measuring the volumetric flow rate, the method provides information on the type of liquid product based on the sound velocity that is measured in parallel.

Ultrasonic flow measurement by the transit-time differential method is now one of the most universally applied flowmetering processes. It is used for measuring cryogenic gases from -200°C, and hot liquids, gases and steam up to 500°C and above, and pressures up to 1500 bar, also for custody transfer applications for liquids other than water. Special versions are approved for custody transfer for volumetric gas meters (from domestic up to large-size meters), as volumetric measuring units for measurement of thermal energy and even for liquids, other than water, with accuracy specifications below 0.2% of the measured value.

In addition, special versions are available as volumetric measuring units for domestic calorimetric meters or as domestic gas meters. These are not discussed here.

Acoustic properties of liquids and gases

Ultrasound is sound with frequencies above the limit audible to man (typically 18 kHz). Fig. 1 shows sound frequencies occurring in nature and those used for ultrasonic flowmetering. Sound waves propagate at the velocity of sound c . Fig. 2 shows the velocities of sound in various materials.

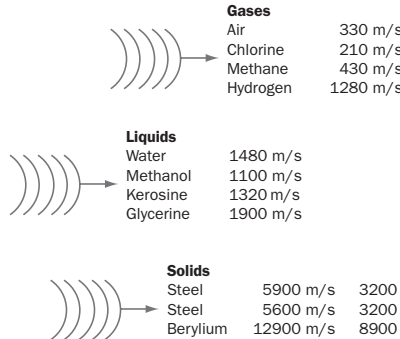

Gases		
Air	330 m/s	
Chlorine	210 m/s	
Methane	430 m/s	
Hydrogen	1280 m/s	
Liquids		
Water	1480 m/s	
Methanol	1100 m/s	
Kerosine	1320 m/s	
Glycerine	1900 m/s	
Solids		
Steel	5900 m/s	3200 m/s
Steel	5600 m/s	3200 m/s
Beryllium	12900 m/s	8900 m/s

Fig. 2:
Velocity of sound c
in various media
(at standard
conditions)

For sound waves to propagate, if possible in the undamped state,

- ultrasonic flowmeters for liquids operate with sound frequencies in the "Megahertz" range,
- ultrasonic flowmeters for gases operate with sound frequencies in the "100 Kilohertz" range.

Ultrasonic Doppler flowmeters

The principle

Doppler flowmeters operate similarly to the radar speed traps used on the road.

An emitter sends ultrasonic waves at frequency f_1 (approx. 1 - 5 MHz) at angle α into the flowing product. The ultrasonic waves strike particles moving through the sound field at velocity v_p . The wavelength of the emitted wave at frequency f_1 amounts to:

$$\lambda_1 = c / f_1$$

Due to its rate of motion v_p , the particle moving away from the emitter 'sees' the wavelength:

Due to its rate of motion v_p , the particle moving away from the emitter 'sees' the wavelength:

$$\lambda_p = (c - v_p \cdot \cos\alpha) / f_1$$

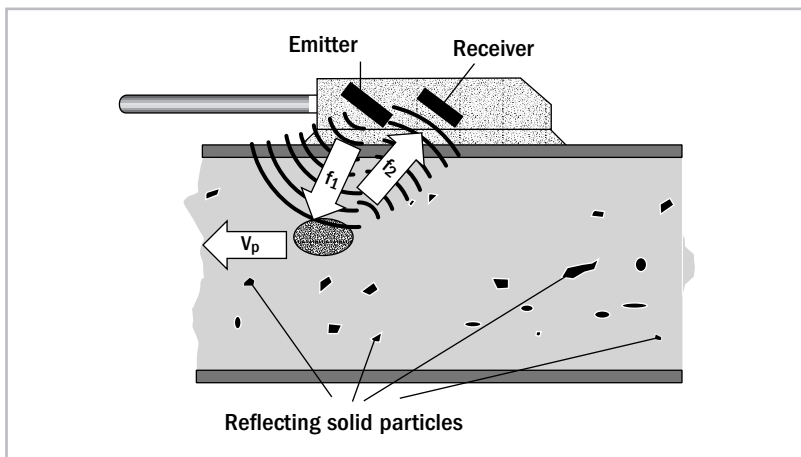

Fig. 3:
Principle of the
Doppler flowmeter

In turn, the receiver now 'sees' the reflected frequency out of line because the reflecting particle is moving further away all the time, and the wavelength changes as follows:

Hence:

$$\lambda_2 = (c - 2 \cdot v_p \cdot \cos\alpha) / f_1$$

For $v_p \ll c$ we obtain:

$$f_2 = \frac{f_1 \cdot c}{c - 2 \cdot v_p \cdot \cos\alpha}$$

This difference in frequency is therefore a linear measure of the rate of motion of the particles.

$$f_2 - f_1 = \Delta f = \frac{2 \cdot v_p \cdot f_1 \cdot \cos\alpha}{c}$$

Advantages of the ultrasonic Doppler flowmeter

- easy to install on existing pipelines (clamp-on versions)
- non-invasive, no moving parts, no wear

Drawbacks and limitations of the ultrasonic Doppler flowmeter

- The measuring method needs a sufficient number of reflecting particles in the medium on a continuous basis.
- The particles must be large enough to provide sufficiently good reflections ($> \lambda/4$).
- The sound velocity of the particulate material must be distinctly different from that of the liquid.
- The sound velocity of the medium is directly included in the measurement result.
- The particle velocity often differs noticeably from the velocity of the liquid.
- Usually, the ultrasonic field extends only into the peripheral flow. That is why indication is heavily dependent on the flow profile.
- The velocity needs to be far higher than the critical velocity at which particles settle.
- Very long unimpeded inlet runs ($20 \times D$) are needed to allow conclusions to be drawn from the flow rate.

Application fields for ultrasonic Doppler flow measurement

Medical applications (measurement of the blood flow)

Absolute accuracy is not a requirement. Only good dynamic performance is required which reproduces blood pulsation in the veins and arteries in great detail for diagnosis (similar to an ECG). The sensor pad is simply applied to the skin (with coupling gel) avoiding bleeding.

Measurement of the flow of slurries (e.g. iron ore)

By its very nature, particle concentration is high. The sound velocity of the particles also differs sufficiently from that of the carrier medium. The flowmeter is often used to provide a signal when the velocity drops below the critical level. The penetration depth of the ultrasonic beam, which depends on the concentration, and also the flow profile tend to cause considerable errors of measurement.

Ultrasonic flowmeters by the transit-time differential method, measuring principle

Basically quite simple

To diagonally canoe across a river with the current flow needs less time than crossing against the current flow (see Fig. 4). The stronger the current, then the faster the crossing with the flow than against it. This difference between the travel times with and against the current therefore depends directly on the flow velocity of the river.

This effect is exploited by ultrasonic flowmeters to determine flow velocity and flow rate. Electro-acoustic converters ("piezos", rather like piezo-electric high-tone loudspeakers and microphones) emit and receive short ultrasonic pulses through the product flowing in the tube. The converters are in longitudinal direction located diagonally offset on either side of the measuring tube (see Fig.)



Fig. 4:
More time needed to travel against the current ...

Measuring principle: Determination of flow velocity v

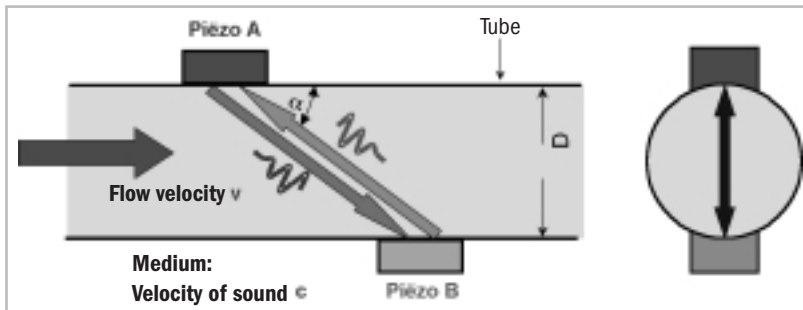

Fig. 5:
Principle of ultrasonic flow measurement according to the transit-time differential method

A pulse travelling *with* the current from piezo A to B needs a transit time of:

$$T_{A \rightarrow B} = \frac{D}{\sin \alpha} \cdot \frac{1}{(c + v \cdot \cos \alpha)}$$

A pulse travelling *against* the current from piezo B to A needs a transit time of:

$$T_{B \rightarrow A} = \frac{D}{\sin \alpha} \cdot \frac{1}{(c - v \cdot \cos \alpha)}$$

The time difference of both pulses comes to:

$$\Delta T = T_{B \rightarrow A} - T_{A \rightarrow B} = v \cdot \frac{T_{B \rightarrow A} \cdot T_{A \rightarrow B} \cdot \sin(2\alpha)}{D}$$

$$v = \frac{D}{\sin(2\alpha)} \cdot \frac{T_{B \rightarrow A} - T_{A \rightarrow B}}{T_{B \rightarrow A} \cdot T_{A \rightarrow B}}$$

Flow rate q is determined from the mean flow velocity.

In a pipeline with circular cross-section the following applies:

$$q = v \cdot A = v \cdot \pi \cdot D^2/4$$

$$q = \frac{\pi \cdot D^3}{4 \cdot \sin(2\alpha)} \cdot \frac{T_{B \rightarrow A} - T_{A \rightarrow B}}{T_{B \rightarrow A} \cdot T_{A \rightarrow B}}$$

The transit time difference is therefore a precise linear measure of the mean flow velocity v along the measuring path (ultrasonic beam). The transit time difference is very small (see Fig. 6).

Examples of transit times, transit time differences:

Inside tube diameter:	100 mm	Transit time difference ΔT : 91.29 ns
Angle of incidence α :	45°	For resolution 0.5%: time resolution <500 ps needed!
Process product	water	The transit time measurement of ...
Sound velocity	1480 m/s	$T_{A \rightarrow B} = 95.4949 \mu\text{s}$
Flow velocity	1 m/s	$T_{B \rightarrow A} = 95.5862 \mu\text{s}$ muss sehr genau sein!
Transit time with the current	95.49 μs	
Transit time against the current	95.59 μs	

Fig. 6:
Examples of transit times

The signal converter, which drives the piezos with pulses and evaluates the received signals, must guarantee this high time resolution. Various methods are used today for this purpose, from the time-proven zero-crossing method, through correlation methods, up to the new complex DSP methods which are designed to improve noise immunity and accuracy.

Determination of sound velocity c

Additionally, the sound velocity c can be determined on-line from the sum total of transit times $T_{A \rightarrow B}$, $T_{B \rightarrow A}$:

$$\Sigma T = T_{B \rightarrow A} + T_{A \rightarrow B} = \frac{1}{c} \cdot \frac{2D}{\sin\alpha} \quad c = \frac{2 \cdot D}{\sin\alpha} \cdot \frac{1}{T_{B \rightarrow A} + T_{A \rightarrow B}}$$

Determination of sound velocity c

The sound velocity c is dependent on the type of product in the measuring tube. Given a change of product in multiproduct pipelines, a change of c signals the passing of the mixed phase. The flow velocity v , measured in parallel, can be used to calculate in advance when this mixed phase will arrive at the tank farm. The mixed phase can then be routed into separate tanks. The sound velocity c also provides information on, for example, the water content in a known oil or the concentration of NaOH (sodium hydroxide solution).

Application limits - gas content / viscosity:

Ultrasonic flowmeters for liquids: the content of gas and solids in the liquid product may not exceed specific limits because damping (also the reflection from interference bodies) would be too high (see Fig. 7).

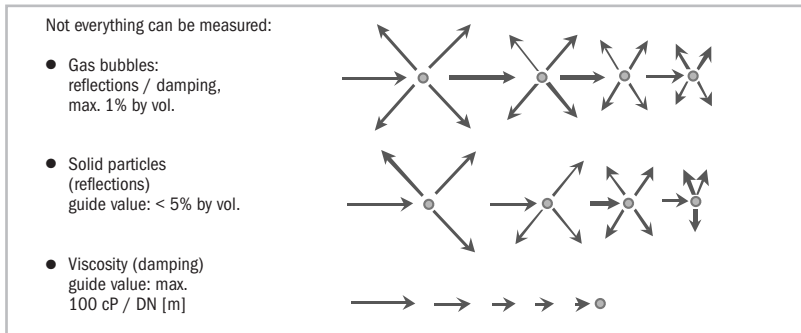

Fig. 7:
Product-based limits of application

Sound waves are pressure waves which generate mechanical waves due to compressibility of the process product. Extremely high viscosity damps this motion and hence propagation of the sound waves. This is why limits are set for viscosity. As a rule, these limits are far above the values occurring in practical operation, and are important only in a very small number of cases. High gas contents cause greater compressibility of the product and extremely low sound velocity. Both effects can cause measurement failure.

Independence from the Reynolds number (flow profile)

Fig. 8 shows a laminar and a turbulent flow profile at the same volumetric flow rate. Some petrochemical products have very high viscosities, so laminar flow can also occur in large-diameter pipelines. If a low-viscosity product is involved, the flow can in turn be turbulent (see Fig. 8).

A flowmeter installed in such a pipeline should indicate the volumetric flowrate correctly and independently of the flow profile.

The ultrasonic flowmeter integrates, or averages, the velocity along its measuring paths.

In laminar flow conditions, and with only one ultrasonic beam passing through the tube centreline, it averages by way of the peak of the parabolic flow profile. In turbulent flow conditions, it averages by way of the much flatter profile. Measurement results are inevitably different.

For accurate flow measurement independent of the Reynolds number, ultrasonic flowmeters are available with a number of measuring channels adapted to the task in hand.

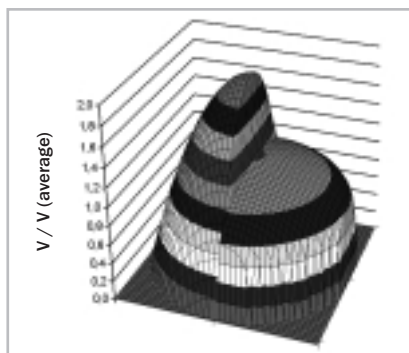

Fig. 8:
Flow profiles at the same flow rate: laminar on the left, turbulent on the right ($Re = 100,000$)

Larger number of measuring paths = greater measuring accuracy at varying Reynolds number

Fig. 9 shows on the left in each case the position of the measuring paths, and on the right a longitudinal section through the tube with implied laminar and turbulent flow profiles in the tube centreline. The values sensed by the measuring beams at laminar flow are marked with dots on the respective profile line.

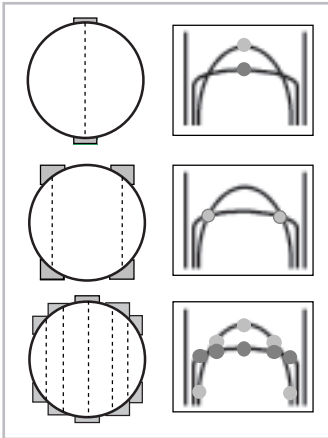

Fig. 9:
Averaging of the flow profile by multi-beam measurement

Single-beam ultrasonic flowmeters, at the top in Fig. 9, are used mostly for turbulent flows, e.g. for water. They show an error of measurement of approx. 30% at the transition from turbulent to laminar flow.

Dual-beam ultrasonic flowmeters, Fig. 9 (centre), show an error of measurement of only 0.5% at this turbulent/laminar transition. They have been used for more than 15 years for process measurements. They are also used for monitoring officially calibrated differential-pressure flowmeters that are subject to wear from the dirt particles in crude oil and then have noticeable measurement errors.

The ALTOSONIC V ultrasonic volumetric meter with 5 measuring paths (at the bottom in Fig. 9) senses the flow profile so well that it can completely compensate for its effects on measuring accuracy and also, given changes from "laminar" to "turbulent", stays well within its allowable error of measurement of $\pm 0.15\%$.

Versions of ultrasonic flowmeters are available today in which the measuring beam is reflected from the tube wall several times in order to reduce the effect of the flow profile (Fig. 10). This method does have its advantages:

- the measuring beam is lengthened compared to the direct transmission methods (Fig. 9),
- accordingly, above all with small meter sizes, the time resolution of signal processing need not be particularly high,
- the beams cross the flow profile several times, thereby achieving the independence from the Reynolds number.

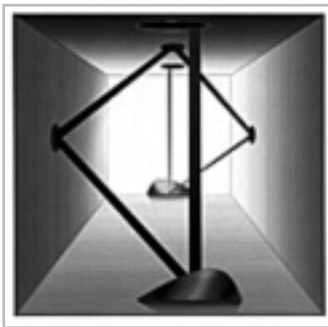

Fig. 10:
Several beams from multiple reflections of one beam

However, this design also involves risks:

- if the tube walls are soiled, the measuring beam fans out more at every reflection so that, given heavier deposits on the walls, the ultrasonic pulse may not be strong enough when it arrives at the receiver.
- In addition, the square shape of the tube can cause heavier deposits in the corners. The resultant changes in cross-sectional area then presumably lead to errors of measurement.

Types of ultrasonic flowmeter operating by the transit-time differential method

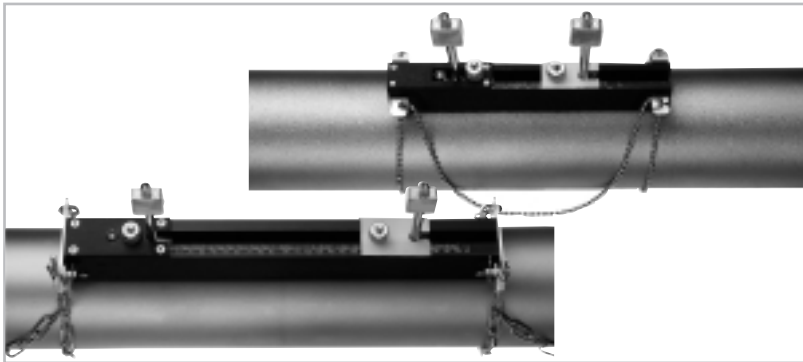

Fig. 11:
Rails for a clamp-on ultrasonic flowmeter (KROHNE UFM 610 P)

Clamp-on flowmeters

For liquid flow measurements on pipelines DN 15 to 5000,

- where the flow rate only needs to be checked from time to time, e.g. pump delivery capacities,
- or where installation of a flowmeter in an existing pipeline is not possible,

special ultrasonic flowmeters are available that can be clamped on to the pipeline.

Such clamp-on devices are available in two versions:

- portable devices for check measurements (see Fig. 12)
- permanently installed industrial measuring devices.

Fig. 11 shows the rails with sensors mounted on a smooth part of the pipeline with strap retainers, chains or similar. For sonic coupling, a coupling grease must be applied between the sensor contact areas and the outside wall of the pipe.



Fig. 12:
Battery-operated signal converter for a clamp-on ultrasonic flowmeter (KROHNE)

The following points need to be borne in mind when selecting the mounting location:

- straight inlet run > 10 D (for details, refer to manufacturer's details)
- Reynolds number > 10,000

Parameters such as

- type of process product (or its sound velocity),
- thickness and material of the pipe wall, and
- diameter of the pipeline

affect the beam's angle of incidence (see Fig. 13), the path length of the sound waves, and hence the transit times and the necessary sensor distance. For that reason, the signal converter (see Fig. 12) polls these parameters in dialog, computes the sensor distance for setting the two sensor assemblies, and includes this data in the flow computation.

Measuring-point data can be stored and used for subsequent measurements. The portable signal converter has an internal data logger to allow recording of the flowrate. This data can then be transmitted via an interface to a PC at a later date.

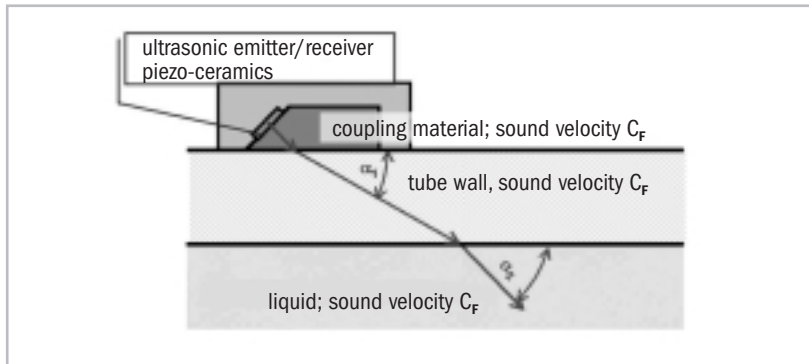

Fig. 13:
Sonic coupling in
clamp-on ultrasonic
flowmeters

Depending on application, the attainable measuring accuracy is 2 ... 5% of the measured value, but the error of measurement can also be higher with small DN meter sizes and higher viscosities. Clamp-on ultrasonic flowmeters can be used on nearly all pipeline materials (except for pipes with loose-fitting liners). Allowable process temperatures are -40 ... +300°C, depending on manufacturer.

In-line ultrasonic flowmeters for liquids, by the transit-time differential method

For continuous process flow measurements with high accuracy requirements, absolutely no maintenance, and the greatest possible independence from the Reynolds number and other process conditions. Measuring devices are permanently installed in the pipeline (in-line).



Fig. 14:
Dual-beam ultrasonic flowmeter ALTOSONIC UFM 500 K, DN 600, PN 10, compact version with integral signal converter

Flanged and welded versions

These devices are available with flanged connections or as pipe sections for welding into the pipeline (see Fig. 14). Such flanged versions with two measuring paths are used, for instance, for volumetric flow measurements ranging from potable water and district-heating water through to crude oil.

Two measuring paths are now the standard

Fig. 15 shows the position of the two parallel measuring paths in the measuring tube. The arrangement of these paths at a defined distance from the pipe centreline assures

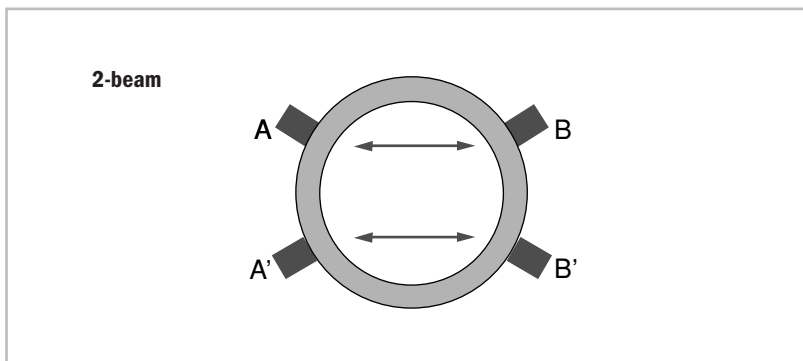

Fig. 15:
Position of measuring paths in the dual-beam ultrasonic flowmeter

practically complete independence from the Reynolds number, i.e. the same measuring accuracy in laminar and in turbulent flow profiles. In addition, using two measuring paths considerably reduces the effect of asymmetrically distorted flow profiles on measuring accuracy.

Field replaceable sensors

Due to the design of the sensor housing, which is fully welded to the measuring tube, and also the solidly welded sonic window, the active sensor elements are also replaceable at process conditions (Fig. 16).

Wide range of meter sizes and flow rates

These devices are available from DN 25 to DN 3000. They can therefore be used for accurate flow measurements in the range of approx. 1 m³/h to over 100.000 m³/h.

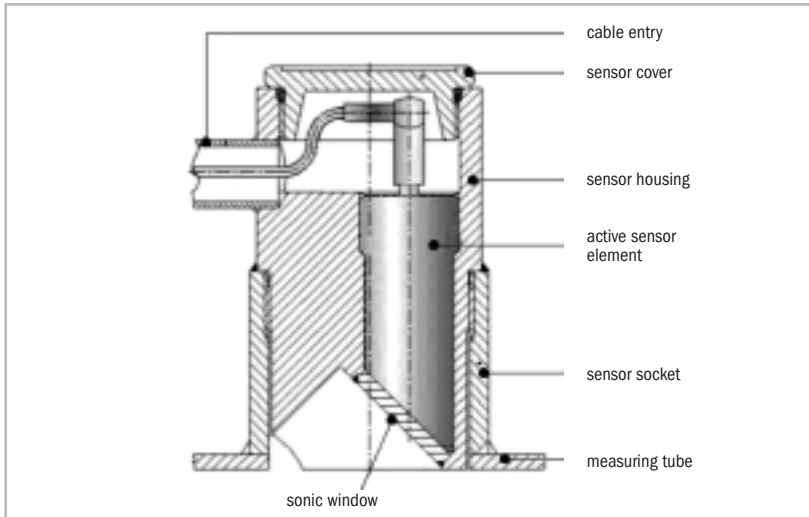

Fig. 16:
The active sensor element is replaceable at process conditions

The "3000 mm" upper limit for meter sizes is set only by the facilities available for calibration. Much larger versions are possible but cannot be wet calibrated. These larger meters over 3000mm would have to be calibrated from computed data such as measurements of the sensor distances and inside diameter of the measuring tube. This method allows for measurement errors of approx. 2% of the measured value to be attained.

Accurate measurement over wide spans

Ultrasonic flowmeters of this type, which are calibrated with water in accurate calibration rigs, nowadays offer a sufficiently high accuracy for process applications, and above all a wide measuring span (see Fig. 17).

Accordingly, they are increasingly replacing displacers and differential-pressure flowmeters which have much smaller measuring spans, lower long-term stability and a shorter service life due to mechanical wear.

"Normal" versions of these in-line flowmeters, depending on manufacturer and type, allow process temperatures up to 150°C or 200°C.

The petrochemical industry in particular has many pipelines operating at process temperatures of 500°C and above, and also at pressures up to 1500 bar, in which flowrates need to be measured. Special versions have been developed for such purposes.

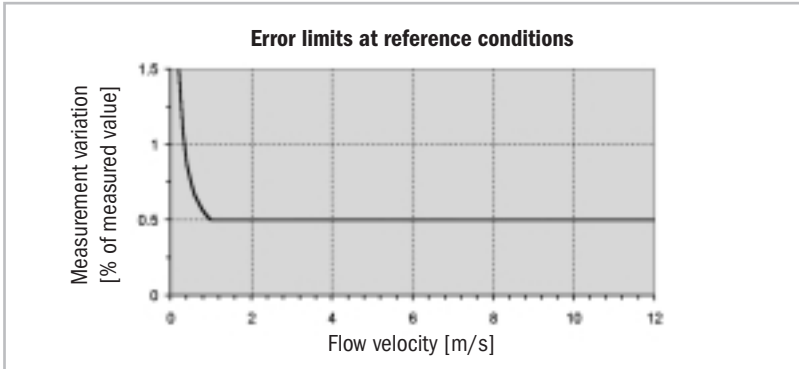

Fig. 17:
Error limits of a dual-beam ultrasonic flowmeter for liquids

**Ultrasonic transit-time differential flowmeters:
temperatures up to 500°C, pressures up to 1500 bar**

These versions operate on the same principle as that described earlier. To protect the piezo-electric sensors from such high temperatures and to avoid restriction of pressure loading from the sonic window, which is normally only a few millimetres thick (see Fig. 16), these sensors are positioned far enough away at the end of a coupling rod (Fig. 18).

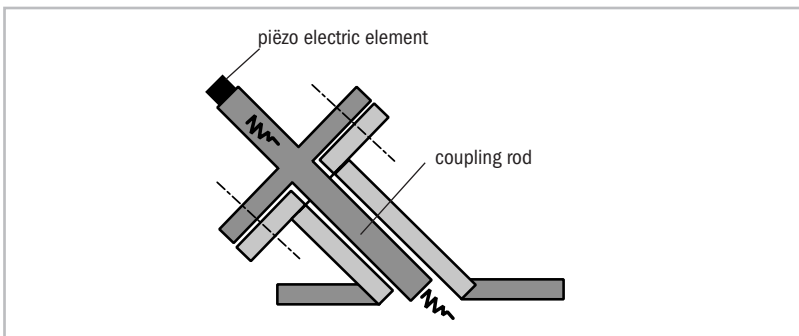

Fig. 18:
Schematic sketch of an ultrasonic high-temperature/high-pressure sensor

The sound waves are transmitted into the medium via this coupling rod, thereby keeping the piezoelectric sensors away from the heat of the measuring tube. Therefore, the mounting flanges for the coupling rod and mounting tube can be designed to withstand pressures up to 1500 bar. Overheating of the piezoelectric element is reliably avoided.

The design of these coupling rods differs according to manufacturer. There are solid rods with a specially shaped outer contour which concentrate the ultrasonic waves in the rod and prevent lateral emittance. Other designs use bundles of thin metal rods inside the coupling rod designed to achieve the same effect.

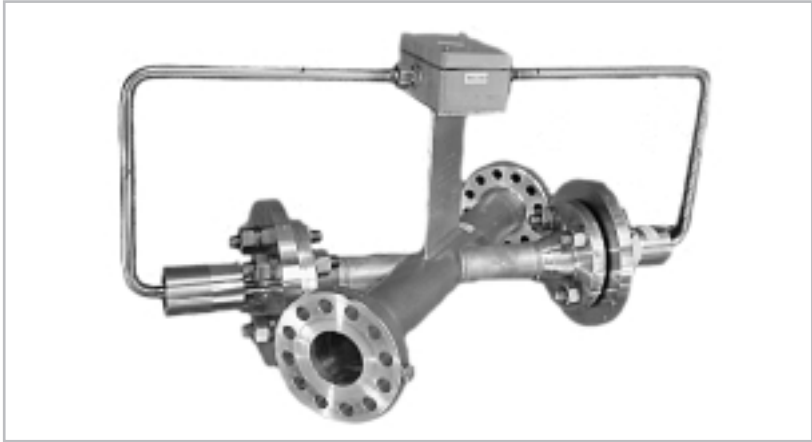

Fig. 19:
*High-temperature
version with heating
jacket for liquid or
steam tracing*

The additional transit times of the ultrasonic pulses when passing through the coupling rod are automatically included by the signal converter when determining times $T_{A \rightarrow B}$ and $T_{B \rightarrow A}$.

For media which solidify or crystallize at low wall temperatures, these flowmeters are also available with a heating jacket (Fig. 19).

In-line ultrasonic flowmeters for gases by the transit-time differential method

The same principle as for liquids

The principle of transit-time differential measurement for gases is the same as that for liquids, except that the sound frequency is lower (typically 100 kHz).

Two measuring paths are now the standard

Improved suppression of the effect of the Reynolds number and of asymmetrically distorted flow profiles on measuring accuracy have almost totally displaced the formerly often used single-beam design from the market.



Fig. 20:
Dual-beam ultrasonic
flowmeter for gases



Fig. 21:
Signal converter
for ultrasonic gas
flowmeters

Accurate measurement over wide spans

Differential-pressure flow measurements have a useful measuring span of approx. 1:3. Independent of density and viscosity, the ultrasonic flowmeter for gases offers a measuring span of approx. 1:10. Measurement stability is not affected by particles in the gas, vibration, or pressure or flow strokes.

Indication of the flowrate in operating units

Indication and outputs of ultrasonic flowmeters for gases are effected in operating units (i.e. according to pressure and temperature at the measuring point). A flow computer is required for flowrate indication and volumetric metering "at standard conditions".

Why ultrasonic flowmeters for process gases?

Non-contact flow measurement and volumetric metering

Apart from tube wall and sonic windows, no parts are in contact with the flowing gas.

Measurement of all gases is made without mechanically moving parts and without any additional pressure drop for meter sizes DN 50 - 600. Flow measurement in both directions is possible.

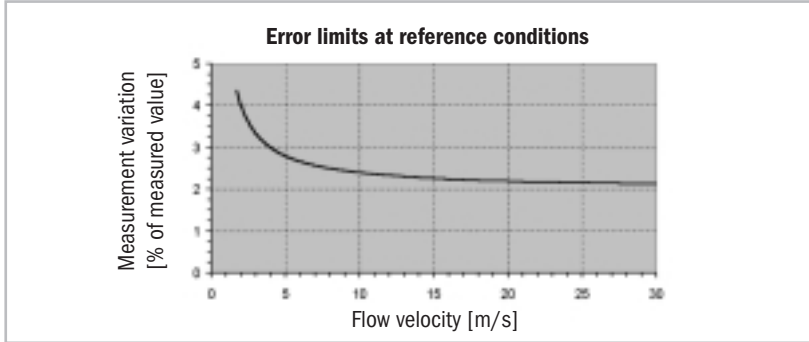

Fig. 22:
Dual-beam ultrasonic flowmeter, errors of measurement

Wide application range

A few examples from the wide range of process products and applications for which ultrasonic flowmeters have been successfully used.

- process products:
natural gas, air, methane, nitrogen, etc.
- optimization of the combustion of residual gases in refineries: flow measurement by way of the transit time difference; in parallel: determination of the molecular weight of gases from the measured sound velocity and other measured variables.

Boundary conditions for ultrasonic gas flowmeters

Sound cannot be transmitted in a vacuum. So transmission of sound between the sensors requires that the gas have a defined minimum density. For that reason, details such as the type of gas, minimum pressure and temperature for which the ultrasonic flowmeter is to be used should be clarified in advance.

The edges of components built into the pipeline, e.g. dampers or valves, act like the lips of organ pipes and can generate high sound levels far above the 100 kHz frequency range required for gas measurement. For that reason, a straight unimpeded inlet pipe run is essential, i.e. with no internals likely to cause separation of the gas flow.

Ultrasonic gas flowmeters are insensitive to

- pressure and flow strokes
- vibration
- dirt particles in the gas

This enables them to be used in applications where conventional methods of volumetric gas measurement, e.g. differential-pressure methods or mechanical meters such as turbines, are liable to fail due to the process conditions.

Ultrasonic gas flowmeters for custody transfer

Large-size ultrasonic gas meters up to approx. 600 mm, and up to 6 measuring paths are available on the market, producing measurement errors of approx. 0.3%

High-temperature versions

"Normal" versions of this ultrasonic gas flowmeter allow process temperatures up to 140°C, depending on manufacturer and type.

The petrochemical industry and public utilities have many pipelines with media temperatures of 500°C and above, as well as pressures up to 1500 bar, in which flow rates need to be measured. Special versions of the ultrasonic gas flowmeter can also be used up to process temperatures of 500°C, e.g. for superheated steam. In terms of principle and outward appearance, these versions are similar to those used for liquids (Fig. 18, Fig. 19).

Weldable sensor assemblies

It does not make economic sense to use complete in-line flowmeters for large-diameter pipelines and non-circular channels. Instead, ultrasonic flow sensors are available as weldable sensor assemblies.



Fig. 23:
Weldable sensors for
metal pipelines

Sensors for measuring the flow in metal pipelines (Fig. 23) are welded from outside into holes drilled into the pipeline. The location of the holes is calculated by the supplier of the ultrasonic sensor assemblies. For inside pipe diameters up to 1000 mm, the sensors are aligned "acoustically", and for larger pipes using a laser alignment kit.



Fig. 24:
Ultrasonic flow sensor
FS 800C for
installation in
channels

Ultrasonic flowmeters with such weldable sensors basically offer the same advantages as the standard in-line ultrasonic flowmeters, i.e.:

- no obstruction in the flow, no pressure drop,
- no mechanically moving parts, no components projecting into the tube, therefore high reliability
- active sensor elements replaceable under process conditions.

The drawback as compared with fully calibrated in-line flowmeters ("measuring

tubes") is that they cannot be calibrated in the normal way, so that calibration factors need to be calculated from pipeline dimensions. That is the main reason for the limit of error being specified as approx. 3% of the measured value.

Sensors that can be bolted solidly to the inside or outside wall of a channel or open race-way are shown in Fig. 24. They can be used for channels up to a width of 8 m.

A ball-and-socket joint provides simple and accurate alignment, which is also carried out using optical means for such long distances.

Ultrasonic volumetric meter ALTOSONIC V for custody transfer

Terms of reference

For custody transfer metering and fiscal accounting of liquid volumes, e.g. offloading from tanker vessels, piped supplies of chemical and petrochemical products, mechanical PD meters, turbines or differential-pressure volumeters have to date been used in the main.



Fig. 25:
Sensor for custody transfer ALTOSONIC V volumetric meter with 5 measuring paths

These technologies are to a certain extent dependent on viscosity, so recalibration must be carried out when there is a change of product. In addition, they are prone to mechanical wear and need to be replaced from time to time. Their meter sizes are limited. Product contamination necessitates the installation of high-maintenance filters in the pipeline. Coriolis mass flowmeters suitable for custody transfer are limited to DN 200 meter size.

In addition, the size limitation of these standard measuring methods makes it necessary to split large-diameter pipelines into several parallel measuring sections and install an equal number of volumetric meters.

Here, the aim was to develop an ultrasonic volumetric meter that could be used up to a size of DN 1000 for flow rates well above 10,000 m³/h and meet the high accuracy demands in custody transfer for liquids, other than water, and independent of product viscosity.

5 measuring paths in the ALTOSONIC V

Five parallel ultrasonic beams measure the flow velocities independently of one another at five levels in the measuring tube. A downstream computer reconstructs the flow profile from the measurements. Special algorithms correct the effect of the profile so that the accuracy of volumetric metering remains within the close limits of 0.15% - 0.2% defined by OIML R 117 and national regulations.

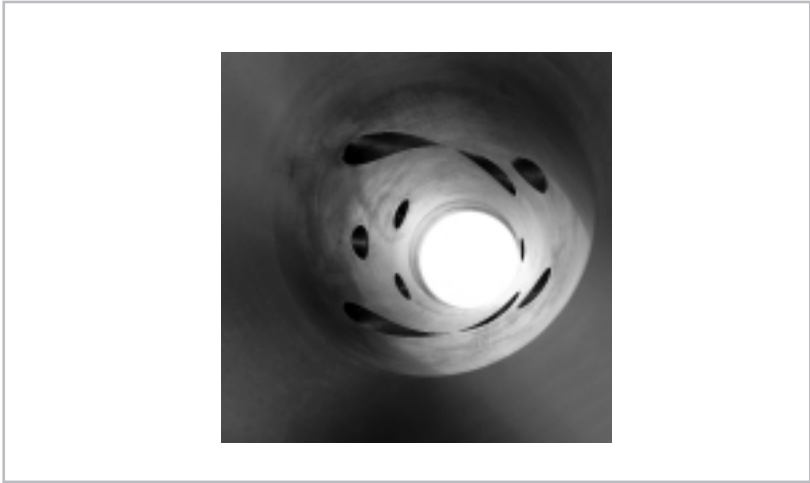

Fig. 26:
*Measuring tube of the
5-beam ultrasonic
volumeter ALTOSONIC V:
clear cross-section!*

The primary head of the ALTOSONIC V volumetric flowmeter (Fig. 25) can simply be installed in the pipeline like a normal section of pipe.

The unobstructed cross-section (see Fig. 26) allows dirt particles to pass through without hindrance. For that reason, no filters are needed upstream of the volumetric meter.

No wear, independent of viscosity

These volumetric meters operate wear-free and reliably without mechanically moving parts or parts projecting into the flow.

Unlike conventional volumetric meters, the measuring accuracy of these ultrasonic meters is retained in full over a viscosity range from 0.1 CSt to 150 CSt. That is ideal for use in multi-product pipelines transporting different products in succession.

With these ultrasonic volumetric devices, recalibration as required for conventional volumetric meters for products with a viscosity deviating from that used in the original calibration is no longer necessary.

Also determines viscosity

The viscosity of the piped product is determined roughly from the measured flow profile by way of the Reynolds number. Like the product-dependent sound velocity measured on-line, this measured variable can be used to identify the product and the passage of mixed phases when there is a change of product.

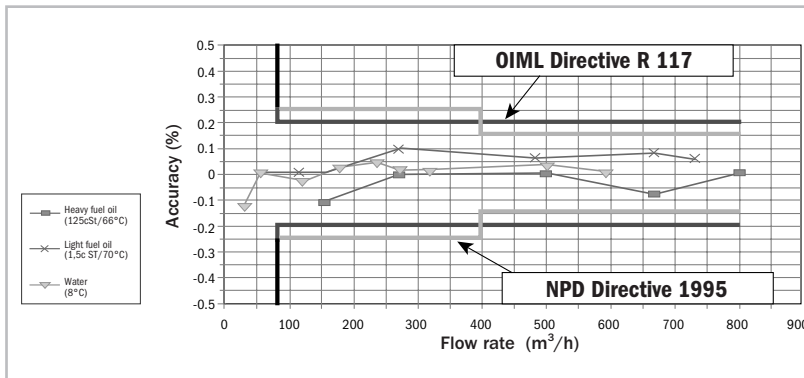

Fig. 27: Ultrasonic volumetric meter ALTOSONIC V: errors of measurement < 0.2% of the measured value, independent of viscosity

Mass flow measurement, mass flow metering and other niceties

Mass flow can be measured when an external densimeter is provided. Together with temperature and pressure measurements, the effects of compressibility and temperature expansion coefficients can be corrected according to API/ASTM formulas.

Redundancy: reliable even after failure of a measuring beam

The signal converter activates an alarm in the event of a sensor (measuring path) failure. The flowmeter, however, remains operating within its specified accuracy because the remaining four beams are not affected and continue to work accurately.

Replaceable ultrasonic converters:

The ultrasonic converters are separated from the product by stainless steel windows. The piezos can be replaced at operating pressure without interrupting the process (see Fig. 16).

Approvals, tests

NMI (Netherlands calibration office) and PTB Brunswick have approved the ALTOSONIC V for custody transfer for liquids other than water according to OIML R 117 with a calibration error limit of 0.2% of the measured value. Other national approvals are in preparation. Further laboratory and field tests are being carried out by various companies in the petrochemical industry and by testing institutes. Typical results are shown in Fig. 27 and Fig. 28.

Ultrasonic volumetric meter for custody transfer in a multiproduct pipeline

The RRB pipeline (Rostock - Böhlen pipeline) started operating in 1997. The RRB is the first pipeline in Germany approved for the transport of combustible liquids and liquefied gas. It handles naphtha / condensate, pentane, liquefied gas C3+ and crude oils.

Fig. 28:
ALTOSONIC V
ultrasonic volumeter:
repeatability: < 0.05%
of the measured value!

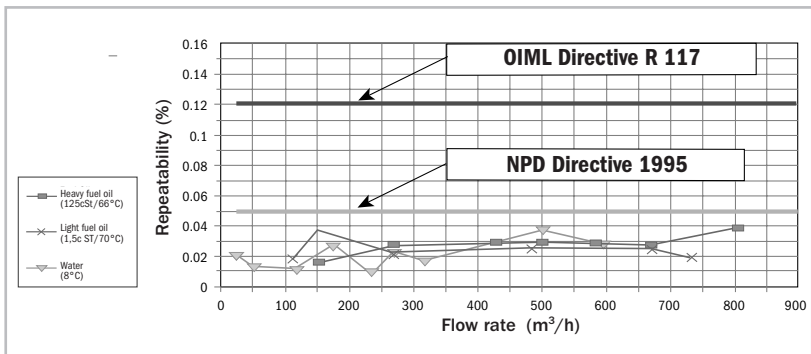

This 430-km long multiproduct pipeline, DN 400, PN 90 bar, is equipped with the only ultrasonic volumetric flowmeters (ALTOSONIC V from KROHNE) certified to date for custody transfer of liquids other than water. They contribute quite substantially towards the economic efficiency and reliability of this pipeline (see Fig. 29).

The measuring data of this 5-beam ultrasonic volumeter with the extremely low measurement uncertainty of 0.15% and a repeatability well below 0.05% are used for

- accurate fiscal accounting of the piped products
- leakage monitoring, identifying leak rates down to 0.5% of the rated flow,
- leakage localization, locating errors down to within a few hundred metres, allowing rapid and successful leakage control, and
- identification of interfaces between different media transmitted successively through the pipeline.

Practice-proven: ultrasonic flowmetering technology

Ultrasonic flowmeters operating by the transit-time differential method have been used for more than 20 years in industrial applications. They measure and count the volumetric flow rates of potable water, service water, district-heating water, acids, oils and all free-flowing products in petrochemical plants. They monitor on- and off-loading of tank trucks and giant fuel tankers, and are also used on offshore drilling platforms.



Fig. 29:
*Calibrated ALTOSONIC V
ultrasonic volumetric
meter with 5 measuring
paths in a pumping
station of the
RRB pipeline*

Portable clamp-on devices operating by the transit-time differential method allow mobile, rapid and simple control of pumping capacities and also other flowmeters. Ultrasonic gas flowmeters are used for measuring off-gas flows, compressed air production and compressor efficiency, and supplies of natural gas in gas-fired power stations. With their flow indication and the molecular weight derived from the measured sound velocity of the gas and other measured variables, they help towards optimization of residual-gas combustion in refineries, so improving efficiency levels and reducing noxious emissions.

The ultrasonic flowmeter is a rugged industrial measuring device which after more than 20 years in industrial application today provides proof of its high reliability, accuracy and stability on a daily basis in the most varied applications.

Due to their high reliability, accuracy, low maintenance requirement, low power consumption and negligible pressure drop, ultrasonic flowmeters rank among the flowmeters with the lowest operating costs (cost of ownership).

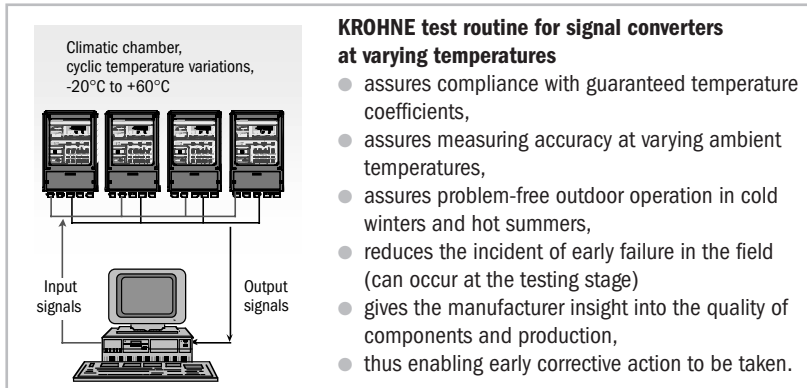

Fig. 30:
The burn-in test for signal converters assures high reliability

Burn-in tests contribute towards this high reliability and low maintenance requirement which KROHNE carry out as a standard routine test on each signal converter before it leaves the factory (for principle, see Fig. 30). This in-house test at varying temperatures pre-empts early failure of electronic components, thus greatly increasing reliability in the field. Proper functioning outdoors can be guaranteed.

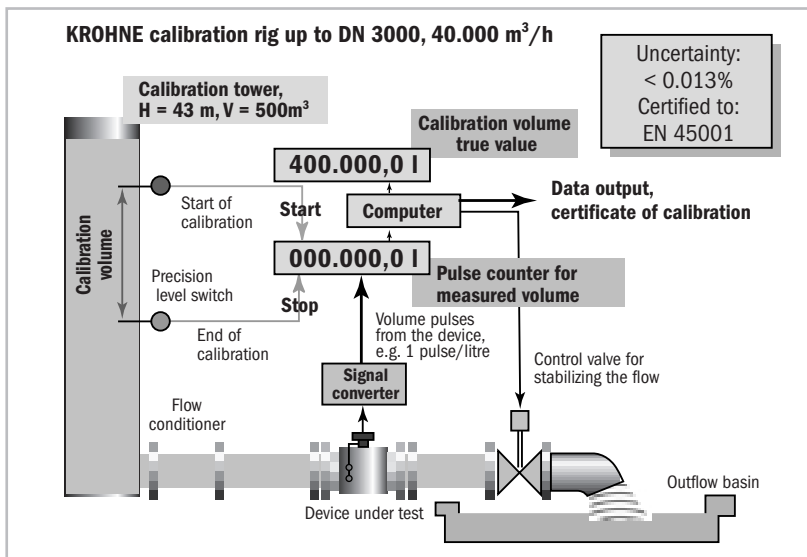

Fig. 31:
Calibration rig for ultrasonic flowmeters up to DN 3000, 40,000 m³/h, principle

The pre-delivery calibration of every single flowmeter on test rigs that are officially supervised and certified to EN 45001, assures quality of measurement and saves the customer having to perform laborious routine tests and "local calibrations" (for principle, see Fig. 31).

The range of application has been greatly extended in recent years by the introduction of UFM's for high-temperature and high-pressure applications for liquids, gases and superheated steam. Accordingly, ultrasonic flowmeters enable measurements to be made in areas for which no suitable flow measuring method had previously been available. Ultrasonic flow measurement is beginning to penetrate the classic fields of application occupied by differential-pressure flowmeters and PD meters.

Advantages of the ultrasonic flow measurement process over most of these classic measuring methods:

- linear, accurate, wide measuring span,
- no wear, no maintenance, long-time stability,
- easy parameter assignment for every measurement task fitting the nominal diameter of the process piping,
- additional information on the process product through parallel output of the sound velocity,
- no additional pressure drop,
- therefore, Lower cost of ownership.

Ultrasonic flowmeters by the transit-time differential method, current limits of application

Process product	Liquids	Liquids	Gases, vapour	Liquids
Version	in-line dual-beam flowmeter	5-beam flowmeter	dual-beam flowmeter	ultrasonic clamp on flowmeter
Metersize [DN [mm]	25 to 5000	100 to 1000	50 to 600	13 to 5000
For flow-metering from m ³ /h ... to ... (approx.)	0.5 m ³ /h ... > 500,000 m ³ /h	30 m ³ /h ... > 10,000 m ³ /h	“standard m ³ “: 7 m ³ /h ... 25,000 m ³ /h	0.3 m ³ /h ... > 500,000
Measurement errors, typically	< 0.5% v. measured value	< 0.15% v. measured value	2% v. measured value	2% v. measured value
Repeatability	< 0.2% v. measured value	< 0.05% v. measured value	< 0.5% v. measured value	< 0.5% v. measured value
Process temperatures	≤ 170°C (200°C) options: 500°C	≤ 120°C	standard: 140°C options: 500°C	< 280°C
Reynolds number range	< 100 ... > 10 ⁶	< 100 ... > 10 ⁶	< 100 ... > 10 ⁶	> 10.000
Operating pressure: through process line	< 1500 bar	Information provided on request	< 100 bar	limited
Media	liquids	liquids	liquids	liquids
Use in hazardous areas	yes	yes	yes	depending on manufacturer
OIML-R 117 approval	no	yes; custody transfer for liquids other than water	no	no

Illustrations

Figure	Page:
Fig. 1: Sound frequencies in nature and in ultrasonic flow measurement	3
Fig. 2: Velocity of sound c in various media (at standard conditions)	4
Fig. 3: Principle of the Doppler flowmeter	5
Fig. 4: More time needed to swim against the current ...	7
Fig. 5: Principle of ultrasonic flow measurement on the transit-time differential method	7
Fig. 6: Example of transit times	8
Fig. 7: Product-based limits of application	9
Fig. 8: Flow profiles at the same flow rate: left: laminar, right: turbulent ($Re = 100,000$)	9
Fig. 9: Averaging of the flow profile by multi-beam measurement	10
Fig. 10: Several beams from multiple reflections of one beam	10
Fig. 11: Rails for a clamp-on ultrasonic flowmeter (KROHNE UFM 610 P)	11
Fig. 12: Battery-operated signal converter for a clamp-on ultrasonic flowmeter (KROHNE)	11
Fig. 13: Sonic coupling in clamp-on ultrasonic flowmeters	12
Fig. 14: Dual-beam ultrasonic flowmeter ALTOSONIC UFM 500 K, DN 600, PN 10,	13
Fig. 15: Position of measuring paths in the dual-beam ultrasonic flowmeter	13
Fig. 16: The active sensor element is replaceable at process conditions	14
Fig. 17: Error limits of a dual-beam ultrasonic flowmeter for liquids	15
Fig. 18: Schematic sketch of an ultrasonic high-temperature/high-pressure sensor	15
Fig. 19: High-temperature version with heating jacket for liquid or steam tracing	16
Fig. 20: Dual-beam ultrasonic flowmeter for gases	17
Fig. 21: Signal converter for ultrasonic gas flowmeters	17
Fig. 22: Dual-beam ultrasonic flowmeter, errors of measurement	18
Fig. 23: Weldable sensors for metal pipelines	20
Fig. 24: Ultrasonic flow sensor FS 800 C for installation in channels	20
Fig. 25: Sensor for custody transfer volumetric meter ALTOSONIC V with 5 measuring paths	21
Fig. 26: Measuring tube of the 5-beam ultrasonic volumeter ALTOSONIC V: clear cross-section	22
Fig. 27: Ultrasonic volumetric flowmeter ALTOSONIC V: errors of measurement < 0.2% of the measured value	23
Fig. 28: Ultrasonic volumetric flowmeter ALTOSONIC V: repeatability < 0.05% of the measured value	24
Fig. 29: Calibrated ultrasonic volumetric meter ALTOSONIC V with 5 measuring paths in a pumping station	25
Fig. 30: Burn-in test for signal converters assures high reliability	26
Fig. 31: Calibration rig for ultrasonic flowmeters up to DN 3000, 40,000 m ³ /h, principle	26



Notes
