

OPTIWAVE 7300 C

Handbook

Non-contact Radar (FMCW) Level Meter

Supplementary Instructions for IECEx applications



KROHNE

All rights reserved. It is prohibited to reproduce this documentation, or any part thereof, without the prior written authorisation of KROHNE Messtechnik GmbH & Co. KG.

Subject to change without notice.

Copyright 2007 by KROHNE Messtechnik GmbH & Co.KG - Ludwig-Krohne-Straße 5 - 47058
Duisburg

1	General safety information.....	4
1.1	Scope of the document	4
1.2	Instrument description	4
1.3	Standards and approvals	4
1.4	Categories	5
1.5	IECEX nameplate	6
2	Installation.....	7
2.1	Precautions	7
2.1.1	General notes	7
2.1.2	Electrostatic discharge.....	7
2.1.3	Special conditions.....	8
2.1.4	Optional flushing system.....	8
2.2	Operating conditions	10
2.2.1	Ambient and flange temperature	10
2.2.2	Maximum surface temperature of the housing	11
2.2.3	Process pressure	11
3	Electrical connections	12
3.1	General notes	12
3.2	Terminal compartment.....	12
3.2.1	How to open the terminal compartment.....	12
3.2.2	How to close the terminal compartment	12
3.3	Terminal tightening capacity	13
3.4	Potential earth (PE).....	13
3.5	How to connect the electrical cables	13
3.6	Supply voltage	14
3.7	Electrical schema	14
4	Start-up	16
5	Service	17
5.1	Periodic maintenance	17
5.2	Keep the instrument clean	17
5.3	Returning the device to the manufacturer	18
5.3.1	General information	18
5.3.2	Form (for copying) to accompany a returned instrument	19
6	Approval certificate	20
7	KROHNE Product Overview	24

1.1 Scope of the document

These instructions are applicable only to the explosion-protection version of the OPTIWAVE 7300 C radar level transmitter. For all other data, use the Quick Start and Handbook. If you do not have these documents, please contact the nearest KROHNE office or download them from KROHNE's website www.krohne.com.

**INFORMATION!**

The information in this manual only contains the data applicable to explosion protection. The technical data in the installation and operating manual for the non-Ex version shall be valid in its current version, provided that they are not rendered invalid or are replaced by this manual.

**WARNING!**

Installation, commissioning and maintenance may only be carried out by "Personnel trained in explosion protection".

1.2 Instrument description

OPTIWAVE 7300 C is a 2-wire level transmitter that uses FMCW (Frequency-Modulated Continuous Wave) radar technology. It measures level, volume, distance to surface, and reflectivity of liquids, pastes, slurries and solid particles, granulates and powders. It is suitable for installation on storage tanks, process tanks and stilling wells. Measurements are displayed via a DTM (device type manager) for remote communication or on an optional integrated display screen with wizard-driven setup and online help functions.

The OPTIWAVE 7300 C is approved for use in potentially explosive atmospheres when equipped with the appropriate options.

1.3 Standards and approvals

**DANGER!**

In compliance with IECEx Scheme rules, the IECEx version of the instrument described in these Supplementary Instructions conforms to International Standards IEC 60079-0, IEC 60079-11, IEC 60079-26, IEC 61241-0 and IEC 61241-11. It is certified for use in hazardous areas by the KEMA Quality B.V. under KEM 06.0025X.

**WARNING!**

Carefully read the IECEx approval certificate for the OPTIWAVE 7300 C. Obey the boundary conditions.

1.4 Categories

This instrument is suitable for use in potentially explosive atmospheres of all flammable substances in Gas Groups IIA, IIB and IIC. It is designed for applications requiring Category 1 G (gases, vapours or mists), 1 D (dust), 1/2 G, 1/2 D, 2 G or 2 D equipment when fitted with the appropriate Ex ia options.



INFORMATION!

Category 1

The instrument is installed in hazardous areas requiring Category 1 G or 1 D equipment.

Category 1/2

The signal converter is installed in hazardous areas requiring Category 2 G or 2 D equipment.

The probe is installed in hazardous areas requiring Category 1 G or 1 D equipment.

Category 2

The instrument is installed in hazardous areas requiring Category 2 G or 2 D equipment.

1.5 IECEx nameplate

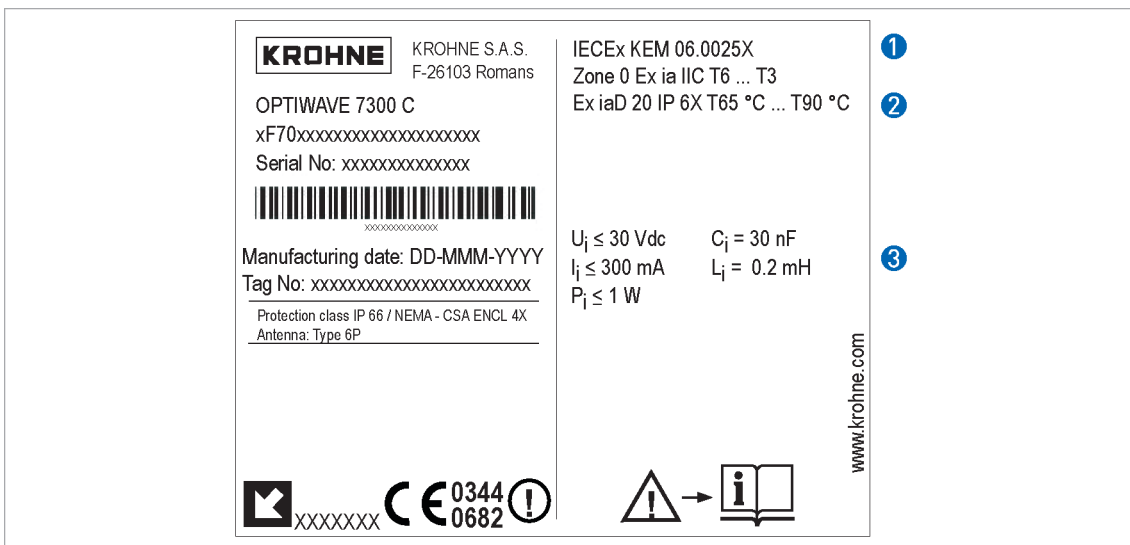

Figure 1-1: IECEx nameplate

- ① IECEx certification agency code. Refer also to **temperature classes**.
- ② Types of device protection including approved Gas Groups (IIA, IIB or IIC) and temperature classes for hazardous areas and maximum surface temperature (please refer to the certificate)
- ③ Intrinsically-safe circuit data

2.1 Precautions

2.1.1 General notes

**WARNING!**

When you install the device, obey the conditions in the IECEx approval certificate. These conditions include:

- *The special conditions for safe use.*
- *The Essential Health and Safety Requirements.*

**DANGER!**

This installation must agree with IEC 60079-14: Electrical installations in hazardous areas.

2.1.2 Electrostatic discharge

**DANGER!**

Risk of electrostatic discharge from the blue plastic sun cover. Make sure that all personnel and equipment are correctly grounded.

Take the necessary antistatic precautions if you:

- handle,
- install or
- use

the instrument in potentially explosive atmospheres. Do not install in a location (near to ventilation systems, for example) where the electrostatic charge can increase.

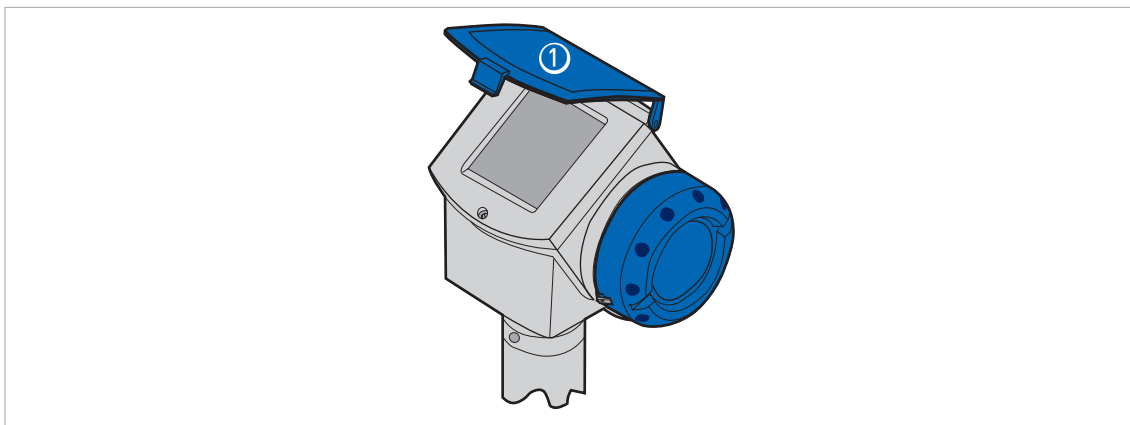

Figure 2-1: Risk of ESD: sun cover

① Sun cover

2.1.3 Special conditions



WARNING!

Aluminium housing: Possible source of ignition in a potentially explosive atmosphere.

The housing is made of either aluminium alloy or stainless steel. If the instrument has an aluminium alloy housing, make sure that iron/steel objects do not hit or rub against the instrument.

2.1.4 Optional flushing system

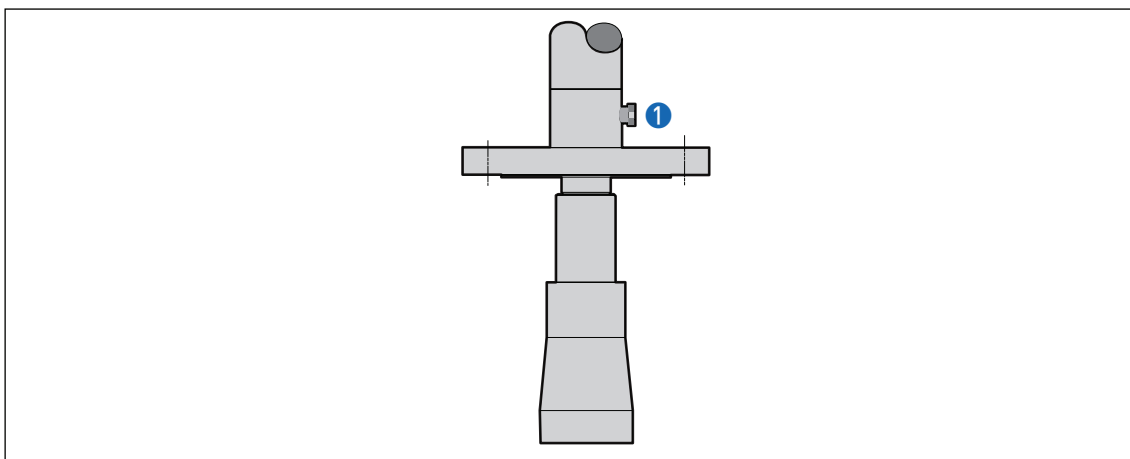

Figure 2-2: Optional flushing system

① NPTF 1/4 flushing connection (optional)

**INFORMATION!**

If delivered with the device, the flushing connection is plugged with a NPTF 1/4 screw and engaged on a minimum of 3 1/2 threads.

Connection and operation of the flushing connection are the responsibility of the user. The operator is also responsible for selection of a suitable fluid to flush the instrument.



- If the screw is removed, make sure that the installation agrees with the Ex requirements for the flushing system.

2.2 Operating conditions

The allowable ambient temperature and corresponding flange temperature range for the instrument depends on the Ex equipment category and temperature classes marked on the nameplate.

2.2.1 Ambient and flange temperature

The Ex equipment category and temperature class give the ambient temperature and related flange temperature ranges for the instrument.

Equipment category II 1 G

Temperature class	Ambient temperature		Flange temperature	
	[°C]	[°F]	[°C]	[°F]
T6	-20...+60	-4...+140	-20...+60	-4...+140

Equipment category II 1/2 G

Temperature class	Ambient temperature		Flange temperature	
	[°C]	[°F]	[°C]	[°F]
T6	-40...+60	-40...+140	-20...+60	-4...+140
T5	-40...+75	-40...+167	-20...+60	-4...+140
T4	-40...+85	-40...+185	-20...+60	-4...+140

Equipment category II 2 G

Temperature class	Ambient temperature		Flange temperature	
	[°C]	[°F]	[°C]	[°F]
T6	-40...+60	-40...+140	-40...+60	-40...+140
	-40...+55	-40...+131	-40...+80	-40...+176
T5	-40...+75	-40...+167	-40...+75	-40...+167
	-40...+70	-40...+158	-40...+95	-40...+203
T4	-40...+85	-40...+185	-40...+85	-40...+185
	-40...+80	-40...+176	-40...+110	-40...+230
	-40...+75	-40...+167	-40...+135	-40...+275
T3	-40...+70	-40...+158	-40...+150	-40...+302
	-40...+65	-40...+149	-40...+180	-40...+356
	-40...+60	-40...+140	-40...+200	-40...+392

Equipment category II 1 D, II 1/2 D and II 2 D

Ambient temperature		Flange temperature	
[°C]	[°F]	[°C]	[°F]
-40...+60	-40...+140	-40...+200	-40...+392

2.2.2 Maximum surface temperature of the housing

Equipment category II 1 D, II 1/2 D and II 2 D

Max. ambient temperature		Max. flange temperature		Max. surface temperature	
[°C]	[°F]	[°C]	[°F]	[°C]	[°F]
+55	+131	+80	+176	+65	+149
+70	+158	+95	+203	+80	+176
+75	+167	+135	+275	+86	+186
+60	+140	+200	+392	+90	+194

2.2.3 Process pressure

Equipment category	Allowable process pressure	
	[kPa]	[psi]
1 G, 1 D, 1/2 G or 1/2 D	80...110 ①	11.6...16 ①
Others	As per non-Ex instrument	As per non-Ex instrument

① atmospheric pressure

3.1 General notes



WARNING!

- De-energize the circuit.
- Do not use the earth terminal in the wiring compartment. Use the equipotential bonding system.
- If ambient temperature $>70^{\circ}\text{C}$, use heat-resistant cables and cable glands certified for continuous operation above 85°C

3.2 Terminal compartment

3.2.1 How to open the terminal compartment

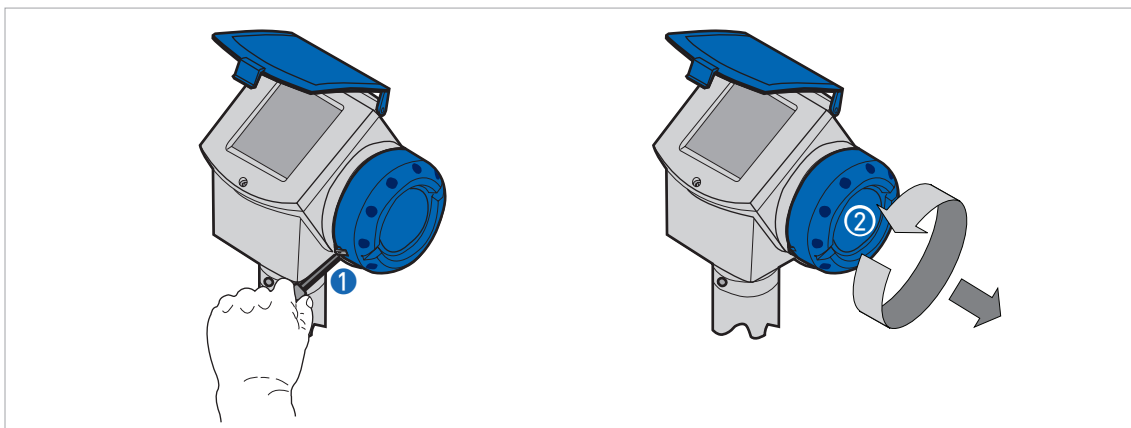

Figure 3-1: How to open the terminal compartment

- ① Cover stop
- ② Terminal compartment cover



WARNING!

Do not remove the terminal compartment cover while the electrical power is connected.

3.2.2 How to close the terminal compartment



WARNING!

Obey the instructions that follow:



- ① Attach the terminal compartment cover ②.
- ➡ Turn the terminal compartment cover carefully to prevent damage to the thread and the gasket.
- ② Make sure that the terminal compartment cover is tight.

- ③ Attach the cover stop ①.
- ➔ Use a 3 mm allen wrench.
- ④ Make sure that the cover stop ① screw is tight.

3.3 Terminal tightening capacity

The terminal tightening capacity for terminals 1 and 2 is:

Type of wire	Terminal tightening capacity	
	[mm ²]	[inches ²]
Rigid	4	0.0062
Flexible	2.5	0.0039

3.4 Potential earth (PE)

Connect an electrical cable with a metallic shield to the PE on one side of the circuit.

3.5 How to connect the electrical cables



INFORMATION!

- *Cable entries are supplied on customer demand. If you supply the cable entries, this part must have a degree of ingress protection IP_{≥66/67} (IEC 60529).*



- Use the electrical connection procedure in the Handbook.
- If possible, use galvanically-isolated equipment.
- Supply the Ex i equipment connected to the instrument. Use only certified intrinsically-safe equipment.
- Connect only to separate certified, intrinsically-safe circuits. Make sure that the electrical circuit characteristics are not more than the values below.

Maximum intrinsically-safe values for the electrical circuit

- $U_i \leq 30 \text{ V}$
- $I_i \leq 300 \text{ mA}$
- $P_i \leq 1 \text{ W}$
- $C_i = 30 \text{ nF}$
- $L_i = 0.2 \text{ mH}$

3.6 Supply voltage

Terminal	Minimum voltage at terminal [VDC]	Maximum voltage at terminal [VDC]
1 (U_{S1})	14 ①	30 ①
2 (U_{S2}) ②	10 ①	30 ①

① for an output of 22 mA

② use a second power supply. This power supply energizes terminal 2 only.

3.7 Electrical schema

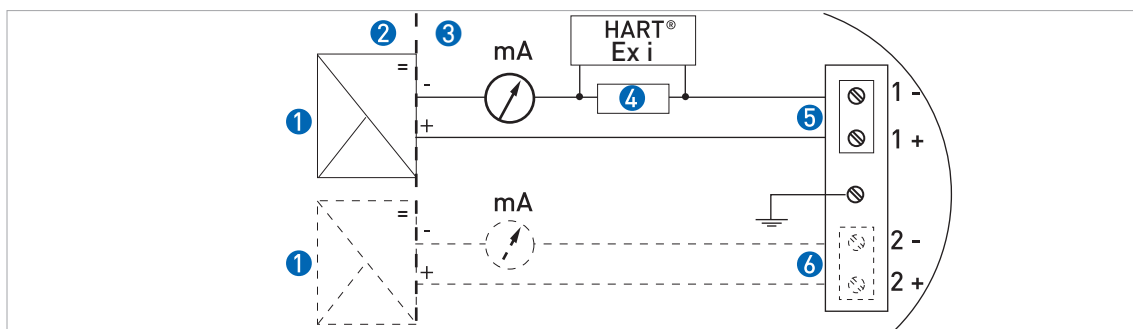

Figure 3-2: HART® connection to the Ex i circuit with a resistor

- ① Intrinsically-safe power supply
- ② Zone non-Ex
- ③ Zone Ex
- ④ Resistor for HART® communication
- ⑤ 14...30 VDC for an output of 22mA at the terminal
- ⑥ 10...30 VDC for an output of 22mA at the terminal

**NOTE!**

If the barrier has a HART[®] terminal, you can connect HART instruments directly to the barrier without a resistor.

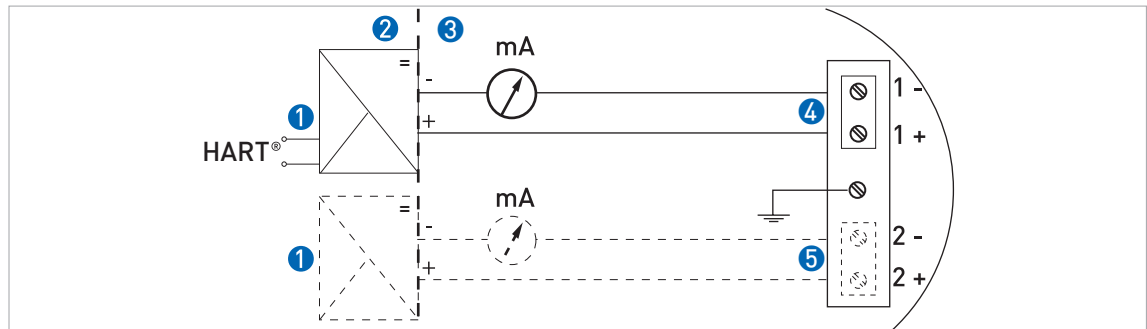

Figure 3-3: HART[®] connection to the Ex i barrier without a resistor

- ① Intrinsically-safe power supply
- ② Zone non-Ex
- ③ Zone Ex
- ④ 14...30 VDC for an output of 22mA at the terminal
- ⑤ 10...30 VDC for an output of 22mA at the terminal

**WARNING!**

Make sure that it is safe to supply electrical power. Do a start-up check:



- Are the wetted components (gasket, flange and antenna) resistant to corrosion by the tank product?
- Does the information given on the nameplate agree with the application?
- Did you connect the equipotential bonding system correctly?
- Are you using an intrinsic barrier within the correct parameters? The electrical circuit characteristics must not be more than the maximum intrinsically-safe values.
- Did you install the correct cable entries? Is the terminal compartment correctly sealed?
- Does the optional flushing system agree with Ex requirements?

5.1 Periodic maintenance

No maintenance is necessary.

5.2 Keep the instrument clean



WARNING!

Do not let more than 5 mm/0.2" of dust collect on the top of the instrument. This is a possible source of ignition in a potentially explosive atmosphere.



DANGER!

Risk of electrostatic discharge from the blue plastic sun cover and the conduit of the remote housing option.



Obey these instructions:

- Keep the thread of the terminal compartment cover clean.
- If dirt collects on the instrument, clean it. Wipe the plastic sun cover with a damp cloth.

5.3 Returning the device to the manufacturer

5.3.1 General information

This device has been carefully manufactured and tested. If installed and operated in accordance with these operating instructions, it will rarely present any problems.



CAUTION!

Should you nevertheless need to return a device for inspection or repair, please pay strict attention to the following points:

- *Due to statutory regulations on environmental protection and safeguarding the health and safety of our personnel, manufacturer may only handle, test and repair returned devices that have been in contact with products without risk to personnel and environment.*
- *This means that the manufacturer can only service this device if it is accompanied by the following certificate (see next section) confirming that the device is safe to handle.*



CAUTION!

If the device has been operated with toxic, caustic, flammable or water-endangering products, you are kindly requested:

- *to check and ensure, if necessary by rinsing or neutralizing, that all cavities are free from such dangerous substances,*
- *to enclose a certificate with the device confirming that is safe to handle and stating the product used.*

5.3.2 Form (for copying) to accompany a returned instrument

Company:		Address:	
Department:		Name:	
Tel. No.:		Fax No.:	
The meter enclosed, type:			
KROHNE Commission or Series No.:			
has been operated with the following liquid:			
Because this liquid is:	<input type="checkbox"/>	hazardous to water	
	<input type="checkbox"/>	toxic	
	<input type="checkbox"/>	caustic	
	<input type="checkbox"/>	flammable	
	<input type="checkbox"/>	We have checked that all cavities in the unit are free from such substances.	
	<input type="checkbox"/>	We have flushed out and neutralized all cavities in the unit.	
We herewith confirm that in returning this unit there is no risk to man or environment through any residual liquid contained in it.			
Date:		Company stamp:	
Signature:			



		<h2 style="text-align: center;">IECEX Certificate of Conformity</h2>	
INTERNATIONAL ELECTROTECHNICAL COMMISSION IEC Certification Scheme for Explosive Atmospheres <small>for rules and details of the IECEx Scheme visit www.iecex.com</small>			
Certificate No.:	IECEX KEM 06.0025X	Issue No.:	0
Status:	Current		
Date of Issue:	2006-05-08	Page	1 of 3
Applicant:	Krohne S.A.S. Quartier des Ors 26103 Romans France		
Electrical Apparatus:	Radar Level Transmitter OPTIWAVE 7300C Type VF70 4 ... and Type SF70 9 ... <i>Optional accessory:</i>		
Type of Protection:	Ex iaD		
Marking:	Ex iaD 21 T 65 ... T 90 IP 6X		
Approved for issue on behalf of the IECEx Certification Body:		T. Pijker	
Position:		Certification Manager	
Signature: (for printed version)		_____	
Date:		_____	
1. This certificate and schedule may only be reproduced in full. 2. This certificate is not transferable and remains the property of the issuing body. 3. The Status and authenticity of this certificate may be verified by visiting the Official IECEx Website .			
Certificate issued by:			
KEMA Quality B.V. Utrechtseweg 310 6812 AR Arnhem The Netherlands			

Figure 6-1: IECEx certificate, page 1 of 3

		<h2 style="margin: 0;">IECEX Certificate of Conformity</h2>	
Certificate No.:	IECEX KEM 06.0025X		
Date of Issue:	2006-05-08	Issue No.:	0
			Page 2 of 3
Manufacturer:	Krohne S.A.S. Quartier des Ors 26103 Romans France		
Manufacturing location(s):			
<p>This certificate is issued as verification that a sample(s), representative of production, was assessed and tested and found to comply with the IEC Standard list below and that the manufacturer's quality system, relating to the Ex products covered by this certificate, was assessed and found to comply with the IECEx Quality system requirements. This certificate is granted subject to the conditions as set out in IECEx Scheme Rules, IECEx 02 and Operational Documents as amended.</p>			
<p>STANDARDS: The electrical apparatus and any acceptable variations to it specified in the schedule of this certificate and the identified documents, was found to comply with the following standards:</p>			
IEC 61241-0 : 2004 Edition: 1	Electrical apparatus for use in the presence of combustible dust - Part 0: General requirements		
IEC 61241-11 : 2005 Edition: 1	Electrical apparatus for use in the presence of combustible dusts - Part 11: Protection by intrinsic safety 'iD'		
<p style="text-align: center;"><i>This Certificate does not indicate compliance with electrical safety and performance requirements other than those expressly included in the Standards listed above.</i></p>			
<p>TEST & ASSESSMENT REPORTS: <i>A sample(s) of the equipment listed has successfully met the examination and test requirements as recorded in</i></p>			
<p><u>Test Report:</u></p> <p>NL/KEM/ExTR06.0024/00</p>			
<p><u>Quality Assessment Report:</u></p> <p>NL/KEM/QAR06.0017/00</p>			

Figure 6-2: IECEx certificate, page 2 of 3

		<h2 style="margin: 0;">IECEX Certificate of Conformity</h2>	
Certificate No.:	IECEX KEM 06.0025X		
Date of Issue:	2006-05-08	Issue No.:	0
		Page 3 of 3	
<h3 style="margin: 0;">Schedule</h3>			
<p>EQUIPMENT: <i>Equipment and systems covered by this certificate are as follows:</i></p>			
<p>Description</p> <p>The Radar Level Transmitters OPTIWAVE 7300 C Type VF70 4 and Type SF70 9 are used for continuous level measurement of flammable or non-flammable liquids or solid particles, granulates or powders within storage or process tanks or in a stilling well. The distance between the antenna and the surface of the process medium is measured using a frequency modulated continuous wave radar. The 2-wire transmitter is loop powered. The output signal is a 4 - 20 mA current signal with digital communication (HART protocol).</p> <p>Optionally, the transmitter may be provided with a second 4 - 20 mA current output and with display and adjustment capabilities (HMI option).</p> <p>The maximum surface temperature of the electronics enclosure "T", depending on the ambient temperature and the flange temperature, is as listed in the following table:</p>			
Max. ambient temperature	Max. flange temperature	Surface temperature "T"	
55 °C	80 °C	65 °C	
70 °C	95 °C	80 °C	
75 °C	135 °C	86 °C	
60 °C	200 °C	90 °C	
<p>The enclosure provides a degree of protection of at least IP 6X in accordance with IEC 60529.</p>			
<p>Electrical data</p> <p>Supply and output circuit (terminals output 1, + and -), intrinsically safe with entity parameters: $U_i = 30 \text{ V}$, $I_i = 300 \text{ mA}$, $P_i = 1 \text{ W}$, $C_i = 30 \text{ nF}$, $L_i = 200 \text{ }\mu\text{H}$.</p> <p>Optional 2nd output circuit (terminals output 2, + and -), intrinsically safe with entity parameters: $U_i = 30 \text{ V}$, $I_i = 300 \text{ mA}$, $P_i = 1 \text{ W}$, $C_i = 30 \text{ nF}$, $L_i = 200 \text{ }\mu\text{H}$.</p>			
<p>CONDITIONS OF CERTIFICATION: YES as shown below:</p> <p>Cable entries and closing elements shall be used that provide a degree of protection of at least IP 6X in accordance with IEC 60529, that are suitable for the application and that are correctly installed.</p>			

Figure 6-3: IECEx certificate, page 3 of 3

KROHNE Product Overview

- Electromagnetic flowmeters
- Variable area flowmeters
- Mass flowmeters
- Ultrasonic flowmeters
- Vortex flowmeters
- Flow controllers
- Level measuring instruments
- Pressure gauges
- Temperature measuring instruments
- Water solutions & analysis
- Oil and gas turnkey solutions

Addresses:

Germany

Northern sales office

KROHNE Messtechnik GmbH & Co. KG
Bremer Str. 133
D-21073 Hamburg
Phone: +49 (0)40 767 3340
Fax: +49 (0)40 767 33412
nord@krohne.de
ZIP code: 10000 - 29999, 49000 - 49999

Western and middle sales office

KROHNE Messtechnik GmbH & Co. KG
Ludwig-Krohne-Straße
D-47058 Duisburg
Phone: +49 (0)203 301 416
Fax: +49 (0)203 301 10416
west@krohne.de
ZIP code: 30000 - 34999, 37000 - 48000, 50000 - 53999, 57000 - 59999, 98000 - 99999

Southern sales office

KROHNE Messtechnik GmbH & Co. KG
Landsberger Str. 392
D-81241 Munich
Phone: +49 (0)89 121 5620
Fax: +49 (0)89 129 6190
sued@krohne.de
ZIP code: 0 - 9999, 80000 - 89999, 90000 - 97999

Southwestern sales office

KROHNE Messtechnik GmbH & Co. KG
Rüdesheimer Str. 40
D-65239 Hochheim/Main
Phone: +49 (0)6146 827 30
Fax: +49 (0)6146 827 312
rhein-main@krohne.de
ZIP code: 35000 - 36999, 54000 - 56999, 60000 - 79999

Instrumentation and control equipment catalog

TABLAR Messtechnik GmbH
Ludwig-Krohne-Straße 5
D-47058 Duisburg
Phone: +49 (0)2 03 305 880
Fax: +49 (0)2 03 305 888
kontakt@tablar.de www.tablar.de

KROHNE sales companies

International

Australia

KROHNE Australia Pty Ltd
Quantum Business Park 10/287
Victoria Rd Rydalmere NSW 2116
Phone: +61 2 8846 1700
Fax: +61 2 8846 1755
krohne@krohne.com.au

Austria

KROHNE Gesellschaft m.b.H.
Modecenterstraße 14
A-1030 Vienna
Phone: +43 (0)1/203 45 32
Fax: +43 (0)1/203 45 32 99
info@krohne.at

Belgium

KROHNE Belgium N.V.
Brusselstraat 320
B-1702 Groot Bijgaarden
Phone: +32 (0)2 4 66 00 10
Fax: +32 (0)2 4 66 08 00
krohne@krohne.be

Brazil

KROHNE Conaut Controles
Automaticos Ltda.
Estrada Das Águas Espraiadas, 230
C.P. 56 06835 - 080 EMBU - SP
Phone: +55 (0)11-4785-2700
Fax: +55 (0)11 4785-2768
conaut@conaut.com.br

China

KROHNE Measurement Instruments
(Shanghai) Co. Ltd., (KMIC)
Room 1501
1033 Zhaojiabang Road
Shanghai 200030
Phone: +86 21 6487 9611
Fax: +86 21 6438 7110
info@krohne-asia.com

Czech Republic

Krohne CZ, spol. s r.o.
Soběšická 156
63800 Brno
Phone: +420 (0)545.242 627
Fax: +420 (0)545 220 093
brno@krohne.cz

France

KROHNE S.A.S.
Les Ors BP 98
F-26103 ROMANS Cedex
Phone: +33 (0)4 75 05 44 00
Fax: +33 (0)4 75 05 00 48
info@krohne.fr

Great Britain

KROHNE Ltd.
Rutherford Drive
Park Farm Industrial Estate
Wellingborough
Northants NN8 6AE
Phone: +44 (0)19 33 408 500
Fax: +44 (0)19 33 408 501
info@krohne.co.uk

CIS

Kanex KROHNE Engineering AG
Business-Centre Planeta
Office 404 ul.
Marxistskaja 3
109147 Moscow/Russia
Phone: +7 (0)095 911 7165
Fax: +7 (0)095 742 8873
krohne@dol.ru

India

Krohne Marshall Ltd.
A-34/35, M.I.D.C. Industrial Area,
H-Block
Pimpri Poona 411018
Phone: +91 (0)202 744 2020
Fax: +91 (0)202 744 2020
pcu@vsnl.net

Iran

KROHNE Liaison Office
North Sohravardi Ave. 26,
Sarmad St., Apt. #9
Tehran 15539
Phone: +9821 8874 5973
Fax: +9821 8850 1268
krohne@krohneiran.com

Italy

KROHNE Italia Srl.
Via V. Monti 75
I-20145 Milan
Phone: +39 02 4300 661
Fax: +39 02 4300 6666
info@krohne.it

Korea

KROHNE Korea
Room 508 Miwon Bldg 43
Yoido-Dong Youngdeungpo-Ku
Seoul, Korea
Phone: 00-82-2-782-1900
Fax: 00-82-2-780-1749
mail@krohne.co.kr

Netherlands

KROHNE Nederland B.V.
Kerkeplaat 14
NL-3313 LC Dordrecht
Phone: +31 (0)78 630 6200
Fax: +31 (0)78 630 6405
Service Direct: +31 (0)78 630 6222
info@krohne.nl

Norway

KROHNE Norway A.S.
Ekholtveien 114
NO-1521 Moss
Phone: +47 (0)69 264 860
Fax: +47 (0)69 267 333
postmaster@krohne.no

Poland

KROHNE Polska Sp.z.o.o.
ul. Stary Rynek Oliwski 8a
80-324 Gdansk
Phone: +48 (0)58 520 9211
Fax: +48 (0)58 520 9212
info@krohne.pl

Switzerland

KROHNE AG
Uferstr. 90
CH-4019 Basel
Phone: +41 (0)61 638 30 30
Fax: +41 (0)61 638 30 40
info@krohne.ch

Singapore

Tokyo Keiso - KROHNE (Singapore)
Pte. Ltd.
14, International Business Park,
Jurong East
Chiyoda Building, #01-01/02
Singapore 609922
Phone: (65) 6567 4548
Fax: (65) 6567 9874
tks@tokyokeiso-krohne.com.sg

Republic of South Africa

KROHNE Pty. Ltd.
Bushbock Close
Corporate Park South
Midrand, Gauteng
P.O. Box 2069
Midrand, 1685
Tel.: +27 (0)11 314 1391
Fax: +27 (0)11 314 1681
midrand@krohne.co.za

Spain

I.L. KROHNE IBERIA, S.r.l.
Poligono Industrial Nilo
Calle Brasil, nº. 5
28806 Alcalá de Henares Madrid
Phone: +34 (0)91 883 2152
Fax: +34 (0)91 883 4854
krohne@krohne.es

USA

KROHNE, Inc.
7 Dearborn Road
Peabody, MA 01960
Phone: +1 (800) FLOWING
Phone: +1 (978) 535 6060 (in MA)
info@krohne.com

Representatives

Algeria
Argentina
Cameroun
Canada
Chile
Columbia
Croatia
Denmark
Ecuador
Egypt
Finland
Gabon
Ghana
Greece
Hong Kong
Hungary
Indonesia
Iran
Ireland
Israel
Ivory Coast
Japan
Jordan
Kuwait
Libya
Lithuania
Malaysia
Mauritius
Mexico
Morocco
New Zealand
Peru
Portugal
Romania
Saudi Arabia
Senegal
Slovakia
Slovenia
Sweden
Taiwan
Thailand
Tunisia
Turkey
Venezuela
Yugostavia

Other countries

KROHNE Messtechnik GmbH & Co. KG
Ludwig-Krohne-Str. 5
D-47058 Duisburg
Phone: +49 (0)203 301 0
Fax: +49 (0)203 301 389
export@krohne.de